

HPI EVOLUTION

Air / water heat pump

AWHP-2 MIT-IN-2 iSystem



Installation and Service Manual

Declaration of conformity

The device complies with the standard type described in the EG declaration of conformity. It was manufactured and commissioned in accordance with European directives.

The original declaration of conformity is available from the manufacturer.

		
Déclaration de conformité CE EC Declaration of Conformity EG- Konformitätserklärung		
L'entreprise soussignée The undersigned Der Unterzeichnete,	De Dietrich S.A.S. 57 Rue de la Gare BP30 F-67580 MERTZWILLER	
Certifie par la présente que les appareils décrits ci-dessous sont conformes aux directives CE afférentes. Toute modification effectuée sur les appareils entraîne l'annulation de la validité de cette déclaration.	Hereby certifies that the following devices comply with the applicable EU directives. This certification loses its validity if the devices are modified.	Bestätigt hiermit, dass die nachfolgend bezeichneten Geräte den nachfolgenden einschlägigen EG-Richtlinien entspricht. Bei jeder Änderung der Geräte verliert diese Erklärung ihre Gültigkeit.
HPI EVOLUTION		
Désignation : Pompes à chaleur	Designation: Heat pumps	Bezeichnung: Wärmepumpen
HPI 4MR-2 HPI 6MR-2 HPI 8MR-2 HPI 11MR/TR-2 HPI 16MR/TR-2 HPI 22TR-2 HPI 27TR-2		
Directives CEE Directive Basse Tension 2006/95/CE Directive CEM 2004/108/CE Directive Équipement Sous Pression 97/23/CE	EC Directives Low voltage directive 2006/95/EC EMC directive 2004/108/EC Pressure equipment directive 97/23/EC	EG-Richtlinien Niederspannungsrichtlinie 2006/96/EG EMV-Richtlinien 2004/108/EG Druckgeräterichtlinie 97/23/EG
Normes appliquées	Applied standards	Angewandte Normen
EN 60335-1: 2002 +A1: 2004 + A2: 2006 + A11: 2004 + A12: 2006 + A13: 2008 EN 60335-2-40: 2003 + A1: 2006 + A2:2009 + A11: 2004 + A12: 2005 EN 55014-1 EN 55014-2 EN 61000-6-2 Ed 2006 EN 61000-6-3 Ed 2007 EN 378-1, EN 378-2+A1, EN 378-3, EN 378-4 EN 14511-1, EN 14511-2, EN 14511-3+EN 14511-3/AC, EN 14511-4		
La déclaration de conformité CE a été délivrée le :	EC declaration of conformity issued on:	Die EG-Konformitätserklärung wurde ausgestellt:
12/03/2014		
Signature / Unterschrift:		
		

C004793-A

Contents

1	Introduction	6
	1.1 Symbols used	6
	1.1.1 Symbols used in the manual	6
	1.1.2 Symbols used on the equipment	6
	1.2 Abbreviations	7
	1.3 Liabilities	7
	1.3.1 Manufacturer's liability	7
	1.3.2 Installer's liability	7
	1.4 Homologations	8
	1.4.1 Certifications	8
2	Safety instructions and recommendations	9
	2.1 Safety instructions	9
	2.2 Recommendations	9
3	Technical description	11
	3.1 General description	11
	3.2 Main parts (Indoor module)	11
	3.2.1 MIT-IN-2/H	11
	3.2.2 MIT-IN-2/E	12
	3.3 Operating principle	12
	3.3.1 General	12
	3.3.2 Skeleton Diagrams	13
	3.3.3 Pressure available	14
	3.4 Technical specifications	14
	3.4.1 Electricity supply	14
	3.4.2 Heat pump	15
	3.4.3 Sensor characteristics	16
4	Installation	17
	4.1 Regulations governing installation	17
	4.2 Package list	17
	4.2.1 Standard delivery	17
	4.2.2 Accessories	18
	4.3 Type plate	19
	4.3.1 Outdoor unit	19
	4.3.2 Indoor module	19

4.4	Installing the outdoor module	20
4.4.1	Positioning of the appliance	20
4.4.2	Main dimensions	22
4.4.3	Locating the outside module	26
4.5	Installing the indoor module	27
4.5.1	Positioning of the appliance	27
4.5.2	Main dimensions	27
4.5.3	Assembly of the indoor module	28
4.6	Installing the outside sensor	29
4.6.1	Choice of the location	29
4.6.2	Connecting the outside sensor	29
4.7	Combination with a DHW tank	30
4.8	Installing the refrigerant piping	30
4.8.1	Installing the pipes	30
4.8.2	Water tightness test	35
4.8.3	Evacuation	35
4.8.4	Opening the valves	35
4.8.5	Adding refrigerant	36
4.9	Hydraulic connections	36
4.9.1	Flushing the system	36
4.9.2	Connection of the heating circuit	37
4.9.3	Hydraulic connection diagrams	37
4.10	Filling the heating system	40
4.10.1	Water treatment in the heating circuit	40
4.10.2	Filling the system	42
4.11	Electrical connections	42
4.11.1	Recommendations	42
4.11.2	Recommended cable cross section	43
4.11.3	Accessing the connection terminal blocks	44
4.11.4	Position of the PCBs	46
4.11.5	Location of the fuse	47
4.11.6	Connecting the outdoor module	47
4.11.7	Connecting the communication cable between the inside and outside modules	47
4.11.8	Description of the terminal block on the inside module	48
4.11.9	Connecting the mains supply to the inside module	49
4.11.10	Connecting the electrical back-up to the inside module	49
4.11.11	Connecting the hydraulic auxiliary on the inside module	51
4.11.12	Connection example for a system with hydraulic back-up	52
4.11.13	Connection example for a system with electrical back-up	57
4.11.14	Connection example in cooling mode	59
4.11.15	Pool connection	61
4.11.16	Connecting the options	63
4.11.17	Connecting the "energy metering" option	64
4.11.18	Connection in cascade	67

	4.11.19	Connection example in power cut off EVU	69
4.12		Electrical principle diagram	71
	4.12.1	Legend	71
	4.12.2	Hydraulic additional heating	73
	4.12.3	Electrical back-up	74
5		Commissioning	75
	5.1	Control panel	75
	5.1.1	Description of the keys	75
	5.1.2	Description of the display	76
	5.1.3	Access to the various browsing levels	79
	5.1.4	Browsing in the menus	80
	5.2	Check points before commissioning	81
	5.2.1	Hydraulic connections	81
	5.2.2	Electrical connection	81
	5.3	Checklist for commissioning (HP)	82
	5.4	Putting the appliance into operation	83
	5.5	Checks and adjustments after commissioning	84
	5.5.1	Displaying the parameters in extended mode	84
	5.5.2	Setting the heating pump speed on the heat pump	84
	5.5.3	Setting the flow rate threshold	85
	5.5.4	Setting the parameters specific to the installation	86
	5.5.5	Naming the circuits and generators	91
	5.5.6	Setting the heating curve	92
	5.5.7	Setting the speed of the heating pump on the inside module	94
	5.6	Reading out measured values	94
	5.7	Changing the settings	96
	5.7.1	Language selection	96
	5.7.2	Calibrating the sensors	96
	5.7.3	Professional settings	98
	5.7.4	Configuring the network	109
	5.7.5	Return to the factory settings	112

6	Switching off the appliance	113
	6.1 Installation shutdown	113
	6.2 Turning on the antifreeze function	113
7	Checking and maintenance	114
	7.1 General instructions	114
	7.2 Maintenance operations to be performed	114
	7.3 Cleaning the 400 µm filter	114
	7.4 Customising maintenance	115
	7.4.1 Maintenance message	115
	7.4.2 Contact details of the professional for After Sales Support	116
8	Troubleshooting	118
	8.1 Anti-hunting	118
	8.2 Messages	118
	8.3 Message history	120
	8.4 Faults (Code type Lxx or Dxx)	121
	8.4.1 Deletion of sensors from the memory in the PCB	124
	8.5 Failure history	125
	8.6 Parameter and input/output check (mode tests)	125
9	Spare parts	131
	9.1 General	131
	9.2 Spare parts	132
	9.2.1 Outdoor unit 4 and 6 kW	132
	9.2.2 Outdoor unit 8 kW	135
	9.2.3 Outdoor unit 11 and 16 kW	138
	9.2.4 Outdoor unit 22 and 27 kW	143
	9.2.5 Indoor module	147

1 Introduction

1.1 Symbols used

1.1.1. Symbols used in the manual

In these instructions, various danger levels are employed to draw the user's attention to particular information. In so doing, we wish to safeguard the user's safety, highlight hazards and guarantee correct operation of the appliance.



DANGER

Risk of a dangerous situation causing serious physical injury.



WARNING

Risk of a dangerous situation causing slight physical injury.



CAUTION

Risk of material damage.



Signals important information.



Signals a referral to other instructions or other pages in the instructions.

1.1.2. Symbols used on the equipment



Protective earthing



Alternating current



Before installing and commissioning the device, read carefully the instruction manuals provided.



Dispose of the used products in an appropriate recovery and recycling structure.



M002628-A

Caution: danger, live parts.
Disconnect the mains power prior to any operations.

1.2 Abbreviations

- ▶ **DHW:** Domestic hot water
- ▶ **PPS:** Polypropylene hardly inflammable
- ▶ **PCU:** Primary Control Unit - PCB controller for heat pump operation
- ▶ **PSU:** Parameter Storage Unit - Parameter storage for PCBs PCU and SU
- ▶ **SCU:** Secondary Control Unit - DIEMATIC iSystem control panel PCB
- ▶ **SU:** Safety Unit - Safety PCB
- ▶ **3WV:** 3-way valve
- ▶ **EVU:** Power supply company
- ▶ **AWHP:** Outdoor module connected by connection cable to the indoor module
- ▶ **MIT-2:** Indoor module fitted with a DIEMATIC iSystem control panel
- ▶ **HP:** Heat pump
- ▶ **EER:** Frigorific efficiency ratio
- ▶ **COP:** Performance coefficient

- ▶ **EER:** Frigorific efficiency ratio

1.3 Liabilities

1.3.1. Manufacturer's liability

Our products are manufactured in compliance with the requirements of the various applicable European Directives. They are therefore delivered with **CE** marking and all relevant documentation.

In the interest of customers, we are continuously endeavouring to make improvements in product quality. All the specifications stated in this document are therefore subject to change without notice.

Our liability as the manufacturer may not be invoked in the following cases:

- ▶ Failure to abide by the instructions on using the appliance.
- ▶ Faulty or insufficient maintenance of the appliance.
- ▶ Failure to abide by the instructions on installing the appliance.

1.3.2. Installer's liability

The installer is responsible for the installation and commissioning of the appliance. The installer must respect the following instructions:

- ▶ Read and follow the instructions given in the manuals provided with the appliance.

- ▶ Carry out installation in compliance with the prevailing legislation and standards.
- ▶ Perform the initial start up and carry out any checks necessary.
- ▶ Explain the installation to the user.
- ▶ If a maintenance is necessary, warn the user of the obligation to check the appliance and maintain it in good working order.
- ▶ Give all the instruction manuals to the user.

1.4 Homologations

1.4.1. Certifications

This product complies to the requirements to the european directives and following standards:

- ▶ 2006/95/EC Low Voltage Directive. Reference Standards: EN60335-1 / EN60335-2-40.
- ▶ 2004/108/EC Electromagnetic Compatibility Directive. Generic standards: EN1000-6-3 , EN 61000-6-1.

2 Safety instructions and recommendations

2.1 Safety instructions



DANGER

If smoke is released or in case of refrigerant leak:

1. Do not use a naked flame, do not smoke, do not operate electrical contacts or switches (doorbell, light, motor, lift, etc..).
Contact between refrigerant and a flame may result in emissions of toxic gases.
2. Open the windows.
3. Trace possible leaks and seal them immediately.



WARNING

Before any work, switch off the mains supply to the appliance.



WARNING

Do not touch the refrigeration connection pipes with your bare hands while the appliance is running. Danger of burns or frost injury.

2.2 Recommendations



WARNING

- ▶ Any intervention on the appliance and heating equipment must be carried out by a qualified engineer.
- ▶ For a proper operating of the boiler, follow carefully the instructions.



Keep this document close to the place where the boiler is installed.

**CAUTION**

- ▶ Use tools and pipe components especially designed for use with R410A refrigerant.
- ▶ Install the appliance on a solid, stable structure able to bear its weight.
- ▶ Use phosphorous-deoxidised copper for pipes without welds and copper alloy to connect the pipes carrying the refrigerant.
- ▶ Use only R410A gas to fill the pipes with refrigerant.
- ▶ Do not install the appliance in a place where it may be exposed to steam, sulphuric gas or combustion, an atmosphere with a high salt content, or which may be covered by snow.
- ▶ Ensure correct earthing.
- ▶ Store the refrigeration connection pipes away from dust and humidity (danger of damage to the compressor) and cover both ends until the expansion process is complete.
- ▶ Do not use a load cylinder.

**CAUTION**

- ▶ Activate the main switch at least **12** hours before the appliance starts to function. Using the appliance just after it is switched on may seriously damage the internal parts.
- ▶ When switching off the appliance, wait for at least **5** minutes of post-operation before deactivating the main switch. Danger of breakdown or water leak.

**CAUTION**

In order to limit the risk of being scalded, the installation of a thermostatic mixing valve on the domestic hot water flow piping is compulsory.



Before carrying out any maintenance work requiring the shutdown of the inside module, also cut the power supply to the outside module to prevent any errors in communication.

3 Technical description

3.1 General description

The AWHP-2 MIT-IN-2 iSystem heat pump is composed of two elements:

- ▶ The outside unit handles energy production in hot or cold mode.
- ▶ The inside module handles thermal exchange between the R410A fluid and the hydraulic circuit.

The two units are connected by means of refrigeration and electrical connections.

The system offers the following advantages:

- ▶ The heating circuit is housed in the insulated volume within the home. There is no danger of the pipes freezing.
- ▶ Thanks to the DC inverter system, the heat pump modulates its output to adapt to the needs of the home.
- ▶ The control panel uses the outside temperature sensor to adjust the temperature of the heating circuit according to the outside temperature.

3.2 Main parts (Indoor module)

3.2.1. MIT-IN-2/H

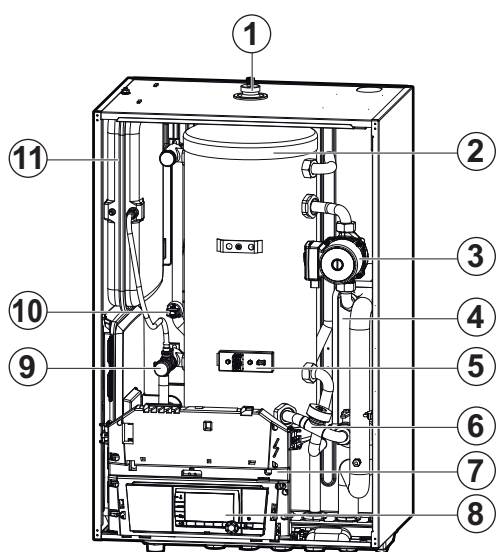

M002483-A

- | | |
|----|------------------------------------|
| 1 | Automatic air bleed |
| 2 | tank |
| 3 | High energy efficient heating pump |
| 4 | Plate heat exchanger |
| 5 | electrical support |
| 6 | Flowmeter |
| 7 | Table cover unit |
| 8 | Control panel |
| 9 | Safety valve |
| 10 | Pressure gauge |
| 11 | Expansion vessel |

3.2.2. MIT-IN-2/E

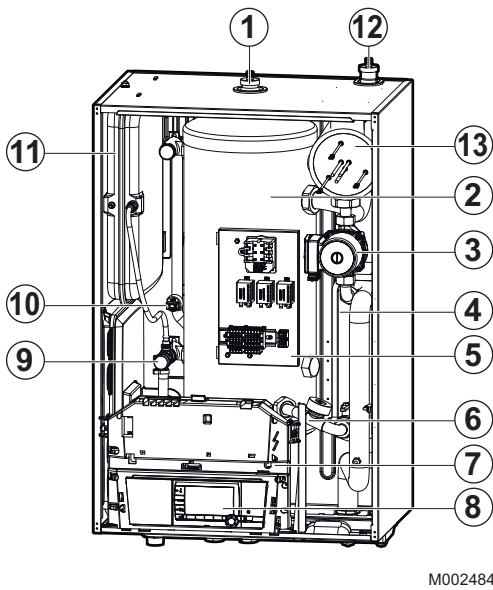

1	Automatic air bleed
2	tank
3	High energy efficient heating pump
4	Plate heat exchanger
5	electrical support
6	Flowmeter
7	Table cover unit
8	Control panel
9	Safety valve
10	Pressure gauge
11	Expansion vessel
12	Automatic air bleed
13	Electric heater

3.3 Operating principle

3.3.1. General

The outside module produces heat or cold (in reversible versions) and transmits it to the heating circuit via the refrigerant in the plate exchanger.

The outside module is capable of operating at outside temperatures down to -20°C (-15°C in the case of a 4 kW or 6 kW heat pump).

The DIEMATIC iSystem control panel is used to programme and regulate the heat pump according to the outside temperature.

By activating the pumps and, where necessary, the mixer valve, the regulator handles the regulation of the heating.

Connection of a CDR4 simplified remote control or a CDI4 interactive remote control enables the auto-adaptivity of the gradient and the parallel offset of the heating curve.

The antifreeze function on the installation is active whatever the operating mode. It is triggered as soon as the outdoor temperature reaches the limiting value preset to $+3^{\circ}\text{C}$.

The installation of a buffer tank is not necessary if the volume of water in the circuit is higher than or equal to 3 litres/kW: Therefore, for a heat pump with an output of less than 11 kW, with a water volume of less than 33 litres, the installation of a buffer tank is necessary.

3.3.2. Skeleton Diagrams

■ MIT-IN-2/H

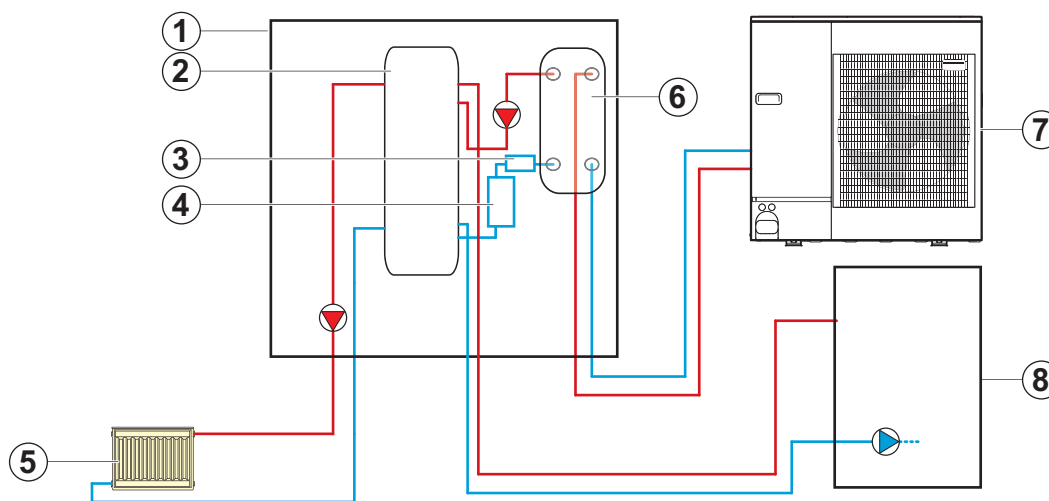

M002487-E

- 1 Inside module with hydraulic back-up
- 2 tank
- 3 Filter
- 4 Flowmeter
- 5 Radiator
- 6 Plate heat exchanger
- 7 Outdoor unit
- 8 Boiler

■ MIT-IN-2/E

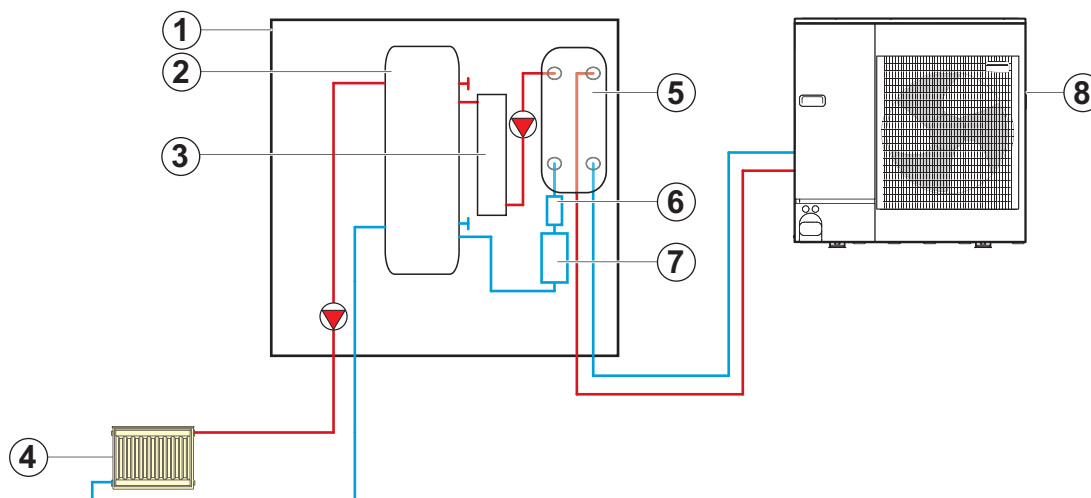

M002488-E

- 1 Inside module with electrical back-up
- 2 tank
- 3 Electrical back-up

- 4 Radiator
- 5 Plate heat exchanger
- 6 Filter
- 7 Flowmeter
- 8 Outdoor unit

3.3.3. Pressure available

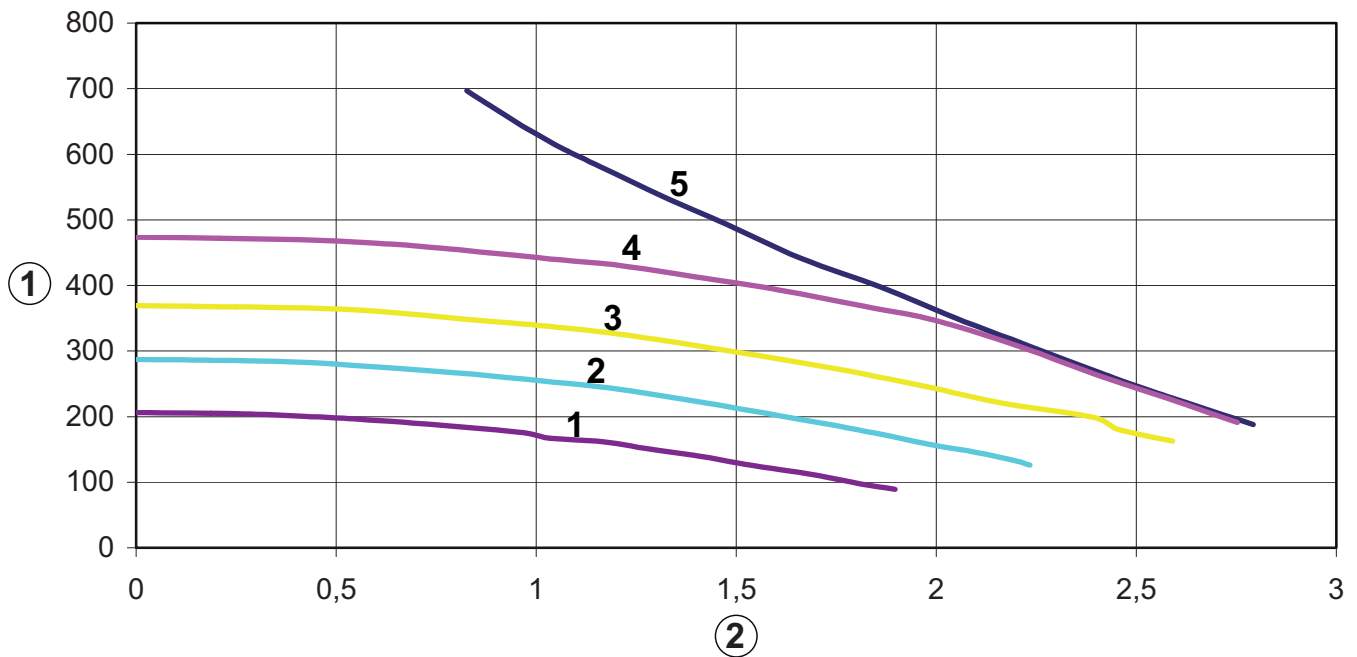

M002627-C

- ① Pressure available (mbar)
- ② Water flow rate (m³/h)
- 1 - 5 Setting the pump

 To set the speed of the heating pump correctly, refer to chapter: "Setting the speed of the heating pump on the inside module", page 94.

3.4 Technical specifications

3.4.1. Electricity supply

230 V AC (+/- 10%) - 50 Hz

400 V AC (+ 6%, - 10%) - 50 Hz (depending on the model)

3.4.2. Heat pump

Conditions of use:

- ▶ Limit operating temperatures in Hot mode:
 - Water: +18 °C / +60 °C
 - Outside air:
 - 15 °C / +35 °C (4, 6 kW)
 - 20 °C / +35 °C (8, 11, 16, 22, 27 kW)
- ▶ Limit operating temperatures in Cooling mode:
 - Water: +7 °C / +25 °C
 - Outside air: +15 °C / +40 °C (At less than 18°C, it is necessary to use the HK24 insulation kit option)
- ▶ Maximum operating pressure: 3 bar

■ Performances in hot mode with outside air temperature at +7°C and outlet water temperature at +35°C (in accordance with EN 14511–2)

AWHP		4 MR	6 MR -2	8 MR-2	11 MR-2	11 TR-2	16 MR-2	16 TR-2	22 TR	27 TR
Calorific output - A7/W35	kW	3.72	5.87	8.26	10.56	10.56	14.19	14.19	19.4	24.4
COP hot - A7/W35		4.30	4.18	4.27	4.30	4.30	4.22	4.22	3.94	3.90
Absorbed electrical power - A7/W35	kWe	0.87	1.41	1.93	2.46	2.46	3.36	3.36	4.92	6.25
Nominal amperage - A7/W35	A	4.11	6.57	8.99	11.81	11.81	16.17	16.17	7.75	9.86

■ Performances in hot mode with outside air temperature at +2°C and outlet water temperature at +35°C (in accordance with EN 14511–2)

AWHP		4 MR	6 MR -2	8 MR-2	11 MR-2	11 TR-2	16 MR-2	16 TR-2	22 TR	27 TR
Calorific output - A2/W35	kW	3.76	3.87	5.93	10.19	10.19	11.38	11.38	12.10	14.70
COP hot - A2/W35		3.32	3.26	3.20	3.20	3.20	3.27	3.27	3.10	3.10
Absorbed electrical power - A2/W35	kWe	1.13	1.19	1.85	3.19	3.19	3.48	3.48	3.91	4.70
Nominal amperage - A2/W35	A	6.1	6.1	8.2	10.7	6.2	14.6	8.4	9.7	11.8

■ Performances in cold mode with outside air temperature at +35°C and outlet water temperature at +18°C (in accordance with EN 14511–2)

AWHP		4 MR	6 MR -2	8 MR-2	11 MR-2	11 TR-2	16 MR-2	16 TR-2	22 TR	27 TR
Cooling output	kW	3.84	4.69	7.90	11.16	11.16	14.46	14.46	17.65	22.2
EER		3.80	3.80	3.99	4.68	4.68	4.43	4.43	3.8	3.8
Absorbed electrical power	kWe	0.72	1.15	2.0	2.35	2.35	3.65	3.65	4.65	5.84

■ General values

AWHP		4 MR	6 MR -2	8 MR-2	11 MR-2	11 TR-2	16 MR-2	16 TR-2	22 TR	27 TR
Sound pressure ⁽¹⁾	dB(A)	41.7	41.7	43.2	43.4	43.4	47.4	47.4	51.8	53
Nominal water flow ($\Delta T = 5K$)	m ³ /h	1.04	1.04	1.47	1.88	1.88	2.67	2.67	3.8	4.6
Manometric height available at nominal flow rate	mbar	618	618	493	393	393	213	213	-	-
Nominal air flow rate	m ³ /h	2100	2100	3000	6000	6000	6000	6000	8400	8400
Power voltage of the outdoor unit	V	230 V~	230 V~	230 V~	230 V~	400 V3~	230 V~	400 V3~	400 V3~	400 V3~
Sound output ⁽²⁾	dB(A)	63.7	63.7	65.2	65.4	65.4	69.4	69.4	73.8	75
R410A refrigerant	kg	2.1	2.1	3.2	4.6	4.6	4.6	4.6	7.1	7.7
refrigerant piping connection (Liquid- Gas)	inch	1/4-1/2	1/4-1/2	3/8-5/8	3/8-5/8	3/8-5/8	3/8-5/8	3/8-5/8	3/8-3/4 or 3/8-1	1/2-3/4 or 1/2-1
Max pre-loaded length	m	10	10	10	10	10	10	10	30	30
Weight (empty) - Outside unit	kg	42	42	75	118	118	130	130	135	141

(1) 5 m from the appliance, free field.
(2) Test conducted in accordance with the standard NF EN 12102

3.4.3. Sensor characteristics

Outside sensor												
Temperature in °C	-20	-16	-12	-8	-4	0	4	8	12	16	20	24
Resistance in Ω	2392	2088	1811	1562	1342	1149	984	842	720	616	528	454

DHW sensor Flow sensor											
Temperature in °C	0	10	20	25	30	40	50	60	70	80	90
Resistance in Ω	32014	19691	12474	10000	8080	5372	3661	2535	1794	1290	941

4 Installation

4.1 Regulations governing installation



CAUTION

Installation of the appliance must be done by a qualified engineer in accordance with prevailing local and national regulations.

4.2 Package list

4.2.1. Standard delivery

The delivery includes:

- ▶ An outside module (See below)
- ▶ An inside hydraulic module (See below)
- ▶ An outside sensor
- ▶ Refrigerant adapter fitting 4, 6 and 22 kW
- ▶ A mounting rail (screwed to the pallet)
- ▶ The installation and maintenance instructions
- ▶ The user instructions

Combinations possible:

Models	Outdoor unit		Indoor module	
	Description	Pack no.	Description	Pack no.
HPI 4 MR-2	AWHP 4 MR	EH336	MIT-IN-2/H 4 - 8 ISYS	EH386
			MIT-IN-2/E 4 - 8 ISYS	EH389
HPI 6 MR-2	AWHP 6 MR-2	EH380	MIT-IN-2/H 4 - 8 ISYS	EH386
			MIT-IN-2/E 4 - 8 ISYS	EH389
HPI 8 MR-2	AWHP 8 MR-2	EH381	MIT-IN-2/H 4 - 8 ISYS	EH386
			MIT-IN-2/E 4 - 8 ISYS	EH389
HPI 11 MR-2	AWHP 11 MR-2	EH382	MIT-IN-2/H 11 - 16 ISYS	EH387
			MIT-IN-2/E 11 - 16 ISYS	EH390
HPI 11 TR-2	AWHP 11 TR-2	EH383	MIT-IN-2/H 11 - 16 ISYS	EH387
			MIT-IN-2/E 11 - 16 ISYS	EH390
HPI 16 MR-2	AWHP 16 MR-2	EH384	MIT-IN-2/H 11 - 16 ISYS	EH387
			MIT-IN-2/E 11 - 16 ISYS	EH390
HPI 16 TR-2	AWHP 16 TR-2	EH385	MIT-IN-2/H 11 - 16 ISYS	EH387
			MIT-IN-2/E 11 - 16 ISYS	EH390
HPI 22 TR-2	AWHP 22 TR	EH225	MIT-IN-2/H 22 - 27 ISYS	EH388
			MIT-IN-2/E 22 - 27 ISYS	EH391
HPI 27 TR-2	AWHP 27 TR	EH226	MIT-IN-2/H 22 - 27 ISYS	EH388
			MIT-IN-2/E 22 - 27 ISYS	EH391

4.2.2. Accessories

Various options are available depending on the configuration of the installation:

■ Heat pump options

Description	package
160 L storage tank	EH 60
80 L storage tank	EH 85
Wall-hanging kit for outside units 6 - 10 kW	EH 95
Condensate receiver tank for wall bracket	EH 111
Ground mounting supports for outside units	EH 112
Electrical resistor for the condensate receiver tank	EH 113
Frigorific ducts with insulation (5/8" - 3/8"); Length: 5 m	EH 114
Frigorific ducts with insulation (5/8" - 3/8"); Length: 10 m	EH 115
Frigorific ducts with insulation (5/8" - 3/8"); Length: 20 m	EH 116
Insulated copper pipe (1/2" - 1/4") 10 m	EH 142
1/4" 1/2" - 3/8" 5/8" adapter fittings	EH 146
Heat pump hydraulic connection kit - DHW storage tank	EH 149
Wall-hanging kit for outside units 11 - 27 kW	EH 250
3-way valve module with standard pump	EA 63
3-way valve module with electronic pump	EA 67
Collector for 2/3 circuits	EA140
Wall console	EA141
Wall console for hydraulic module	EA142
Direct circuit with pump HEE	EA143
V3V circuit with HEE pump	EA144
Wiring kit for connecting a safety thermostat for underfloor heating	HA 249
3-way valve kit	HK 21
2-circuit kit	HK 22
Reversal valve kit	HK 23
Insulation kit cold mode	HK 24
3-way valve insulation kit	HK 25

■ Control system options

Description	package
BUS connection cable (length 12 m)	AD134
voice remote monitoring module	AD152
Outlet sensor V3V	AD199
DHW sensor	AD212
Optional PCB for 3-way valve	AD249
System sensor	AD250
Outside radio-controlled temperature sensor	AD251
Radio module	AD252
CDR iSystem radio remote control	AD284

Description	package
Interactive radio remote control with LCD display CD12/CD14	AD285
Radio remote control	AD253
Interactive remote control	AD254
A simplified remote control with room sensor	FM52
Condensation detector kit	HK 27
Energy metering option	HK 29

4.3 Type plate

4.3.1. Outdoor unit

The type plate must be accessible at all times. The type plate identifies the product and provides the following information:

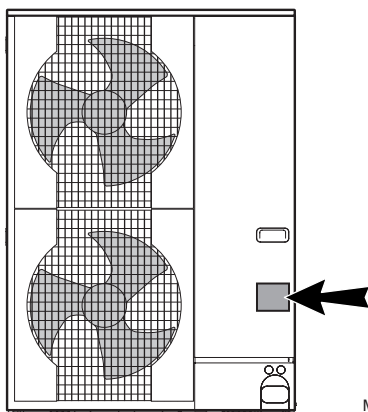

MW-M001832-2

- ▶ Appliance type
- ▶ Manufacturing date (Year - Week)
- ▶ Serial number.
- ▶ Nature of the power supply voltages

4.3.2. Indoor module

- ❶ This data plate is affixed to the inside side panel of the appliance in the factory.
- ❷ When installation has been completed, affix the data plate provided in the instructions bag to the casing of the appliance in a position where it can be seen.

The type plate must be accessible at all times. The type plate identifies the product and provides the following information:

- ▶ Appliance type
- ▶ Manufacturing date (Year - Week)
- ▶ Serial number.
- ▶ Nature of the power supply voltages

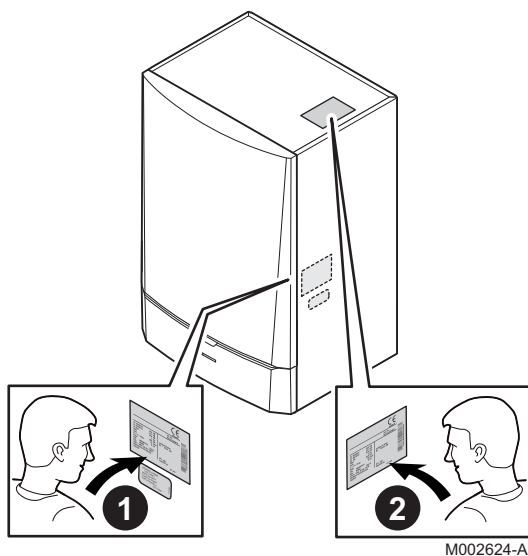

M002624-A

4.4 Installing the outdoor module

4.4.1 Positioning of the appliance

Ensure that the outside module is optimally positioned in relation to neighbours as it is a source of noise.

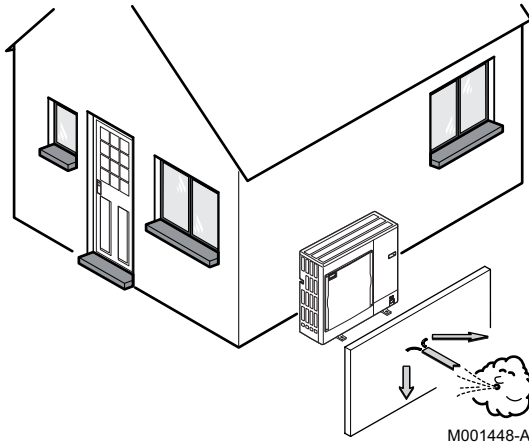

CAUTION

- ▶ There must be no obstacles hindering the free circulation of air around the outdoor module (intake and output).
- ▶ Do not locate the outside unit close to where people sleep.
- ▶ Do not locate the unit opposite a wall with windows.
- ▶ Avoid placing it close to a terrace, etc..

Choose a location away from prevailing winds.

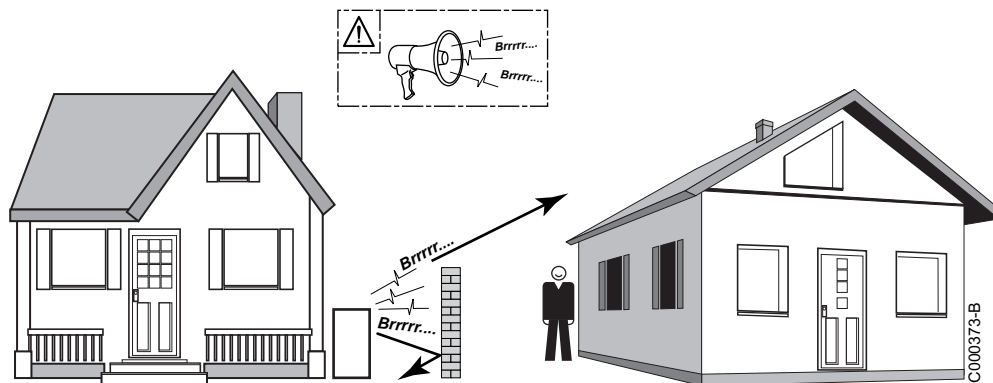

In some cases, additional precautions are necessary owing to the fact, for example, of too short a distance between you and your neighbours.

When installing a **noise reduction screen**, respect the following recommendations:

- ▶ Locate the noise reduction screen as close as possible to the noise source whilst allowing for the free circulation of air in the exchanger on the outside unit and maintenance work.

Place the outside unit on a base (concrete base frame, sill, concrete blocks, etc.) with no rigid connection with the building served in order to prevent any transmission of vibrations. Ensure sufficient above ground elevation (100 to 150 mm) to keep it above water.

For regions where heavy snowfalls occur, raise this above ground protection by at least 200 mm compared with the average depth of the covering of snow.



CAUTION

- ▶ If the outside temperatures become negative, take the necessary precautions to prevent the risk of freezing in the evacuation pipes.
- ▶ Prevent any risk of the condensates freezing in an area through which they flow.
- ▶ The heating cord keeps the condensates from freezing: See EH113 leaflet.

■ Distances to be observed



WARNING

To ensure that the heat pump functions correctly, respect the minimum and maximum connection lengths between the heat pump and the indoor module.

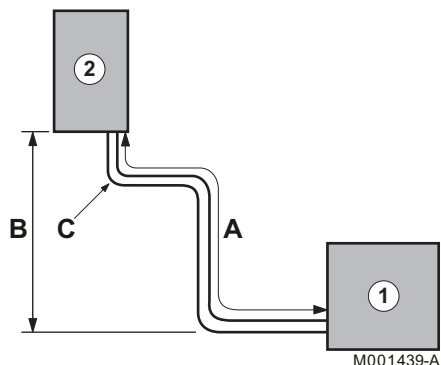

- ① Outdoor unit
- ② Indoor module
- A Minimum length 5 m
Maximum length:
40 m for 4, 6, 8 kW,
75 m for 11, 16 kW,
20 m for 22, 27 kW.
- B Max height difference 10 m For 4, 6, 8 kW
Max height difference 30 m For 11, 16, 22, 27 kW
- C Max number of elbows: 15
Respect the minimum curve radii of 100 to 150 mm



👉 See chapter: "Installing the pipes", page 30.

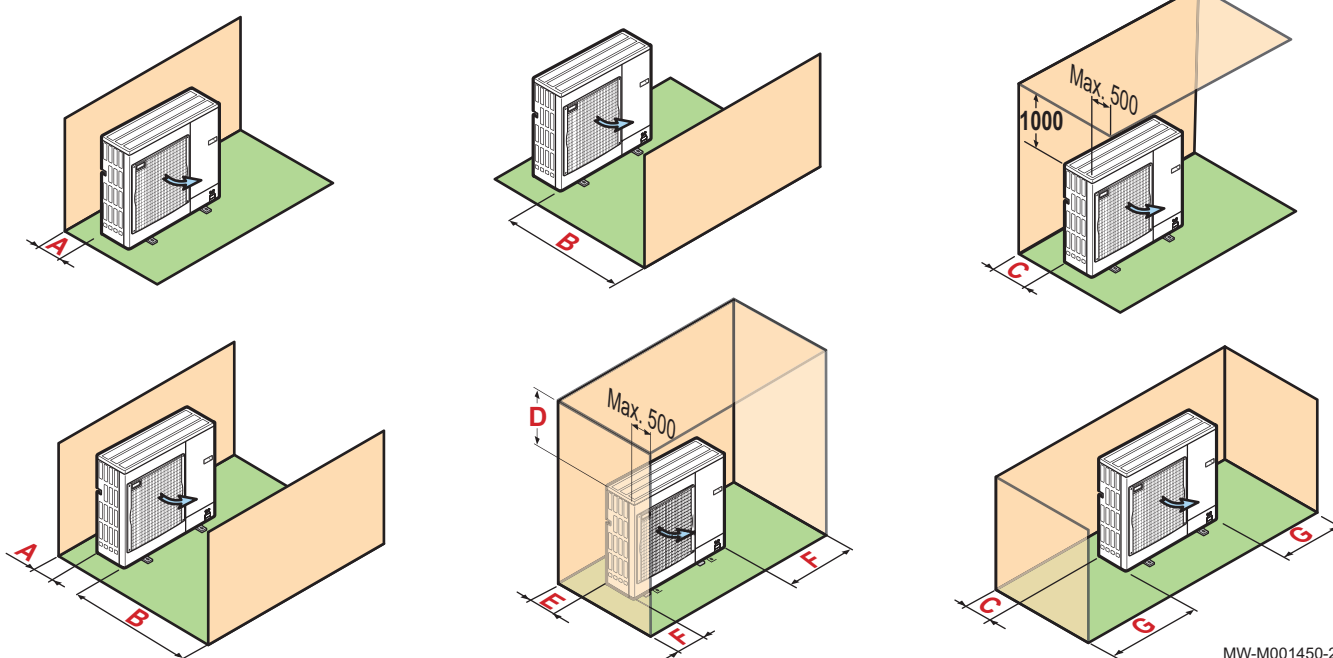

Dimension (mm)	4, 6, 8 kW	11, 16, 22, 27 kW
A	100	150
B	500	1000
C	200	300
D	1000	1500
E	300	500
F	150	250
G	100	200

4.4.2. Main dimensions

■ AWHP 4 and 6 MR-2

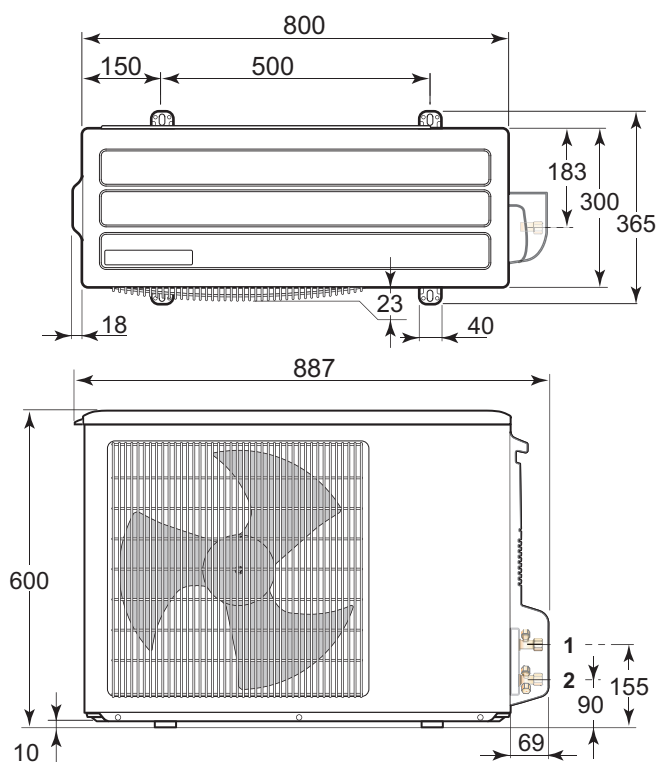

MW-M002199-2

■ **AWHP 8 MR-2**

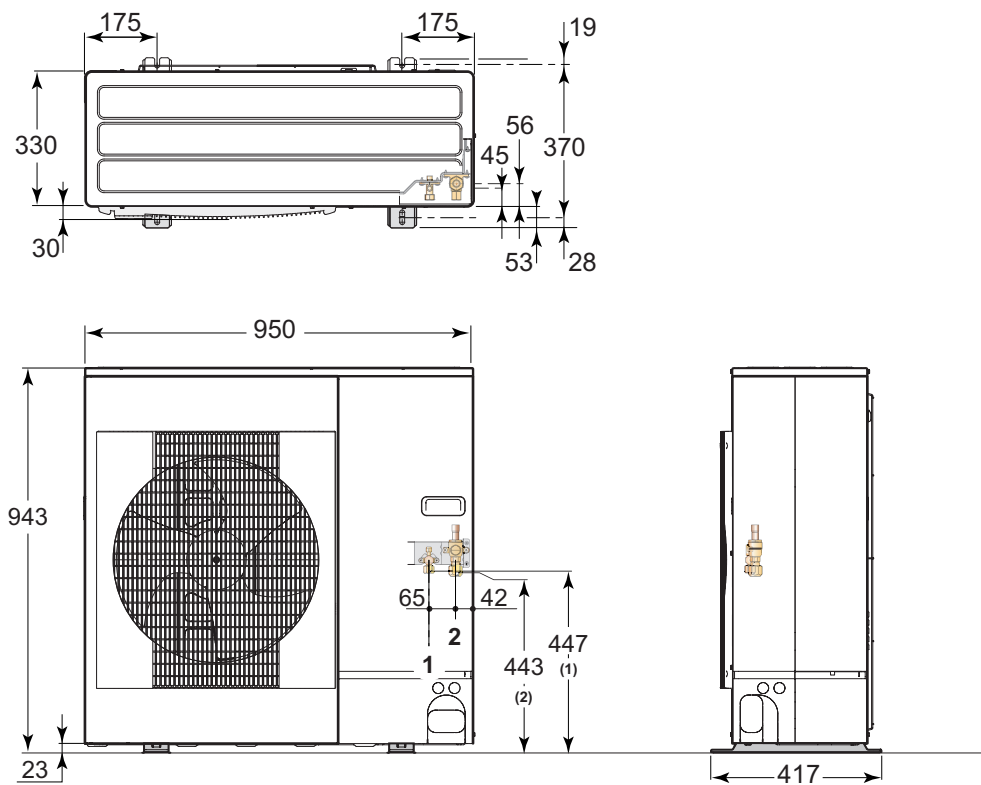

MW-M001442-2

- ① 3/8" flare refrigerant fitting
- ② 5/8" flare refrigerant gas fitting

■ AWHP 11 and 16 MR/TR-2

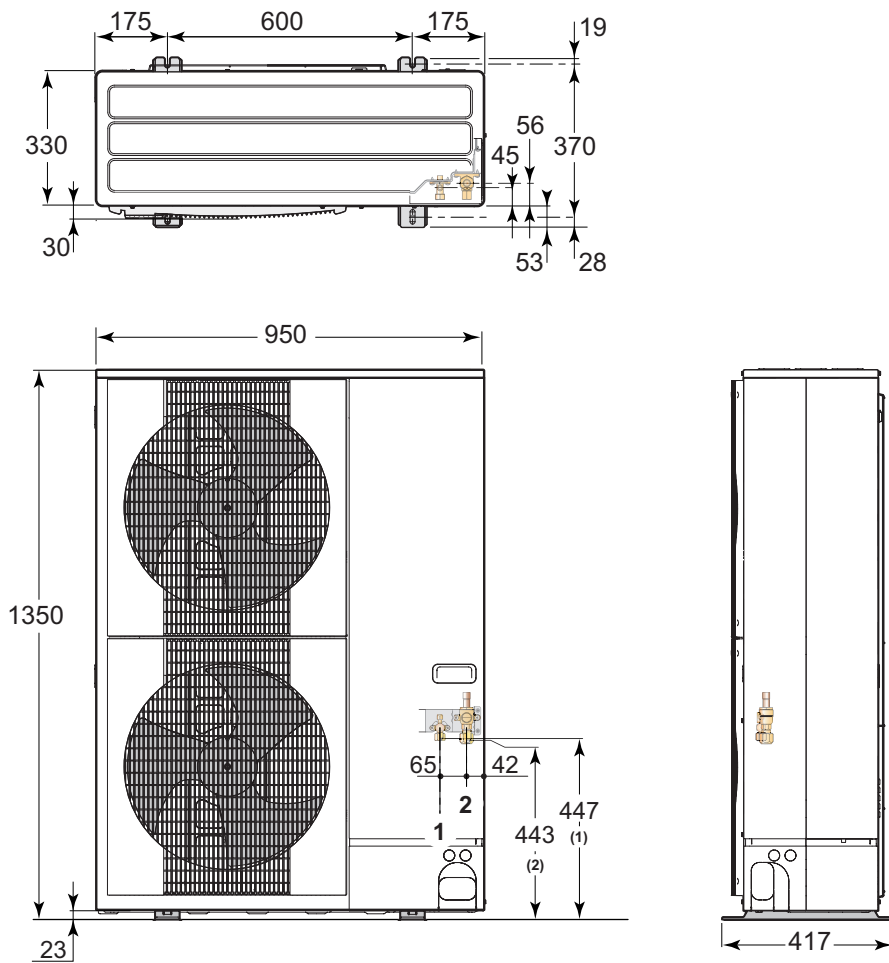

MW-M001443-2

- ① 3/8" flare refrigerant fitting
- ② 5/8" flare refrigerant gas fitting

■ AWHP 22 and 27 TR

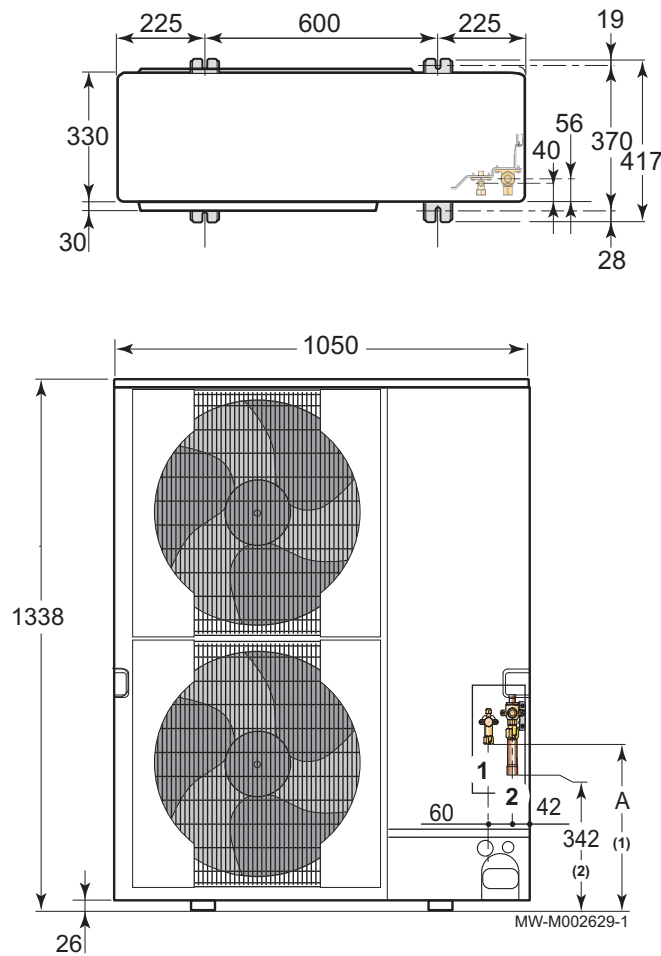

- A** 450 mm : 22 kW
424 mm : 27 kW
- ① 3/8" flare refrigerant fitting (22 kW)
1/2" flare refrigerant fitting (27 kW)
- ② 3/4" flare refrigerant gas fitting + adapter 1" (to be brazed)

4.4.3. Locating the outside module

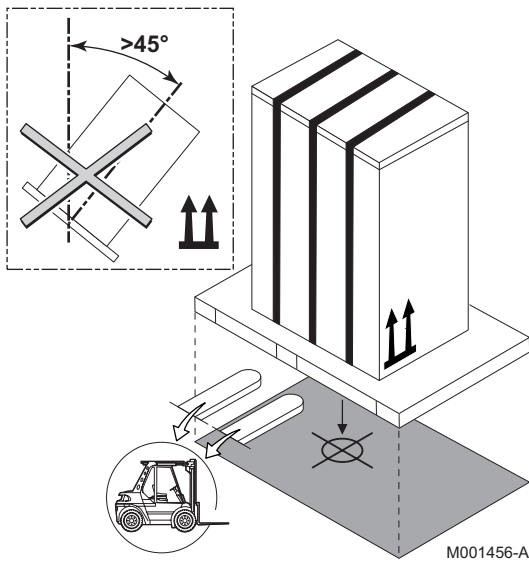

CAUTION

Keep the appliance vertical during transport.

■ Installation on the ground

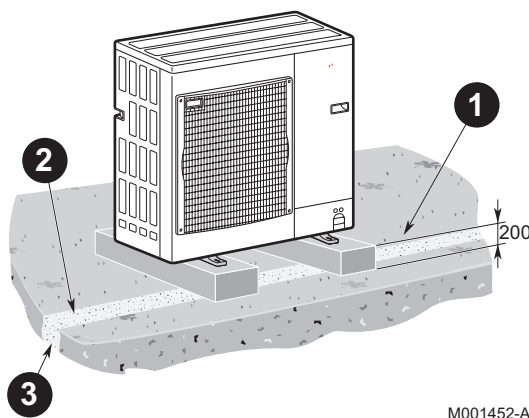

- ① Concrete base frame
- ② Condensates run-off
- ③ Install a run-off channel with pebble bed

- ▶ Use the ground installation base kit available as optional equipment: Package EH112.
- ▶ Install the appliance on a solid, stable structure able to bear its weight.

■ Condensates discharge



CAUTION

If the outside temperatures become negative, take the necessary precautions to prevent the risk of freezing in the evacuation pipes. Use package EH113 (Electrical resistor for the condensate receiver tank). Prevent any risk of the condensates freezing in an area through which they flow.

4.5 Installing the indoor module

4.5.1. Positioning of the appliance

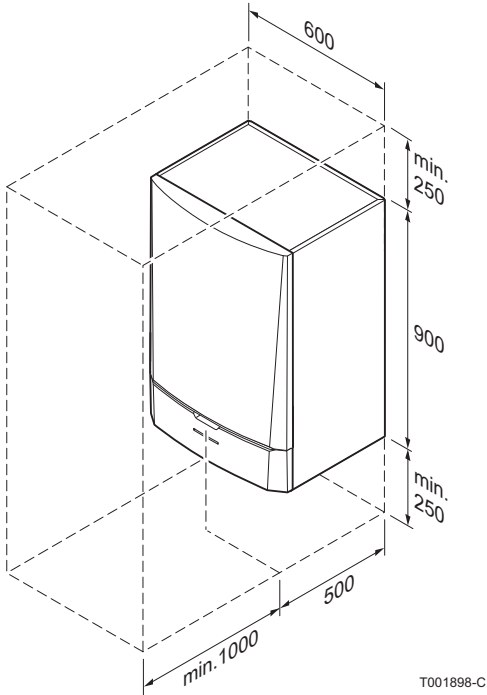

CAUTION

- ▶ Install the appliance in frost-free premises.
- ▶ Fix the appliance to a solid wall capable of bearing the weight of the appliance when full of water and fully equipped.

4.5.2. Main dimensions

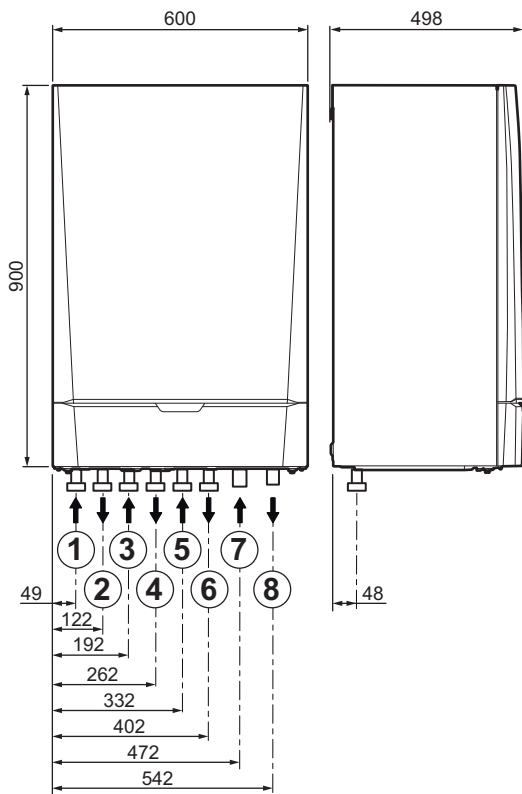

- ① 3-way valve circuit return (Option) - G1"
- ② 3-way valve circuit outlet (Option) - G1"
- ③ Return direct circuit - G1"
- ④ Direct circuit flow - G1"
- ⑤ Back-up boiler inlet - G1"
Only for hydraulic back-up - Version H
- ⑥ Return to the back-up boiler - G1"
Only for hydraulic back-up - Version H
- ⑦ Gas line
5/8" flare connection: 4, 6, 8, 11, 16 kW
3/4" flare connection: 22, 27 kW (Use 1" braze-on adapter)
- ⑧ Liquid line
3/8" flare connection: 4, 6, 8, 11, 16 kW
1/2" flare connection: 22, 27 kW
- G Exterior cylindrical threading, sealed by sheet gasket

4.5.3. Assembly of the indoor module

■ Fitting the mounting rail

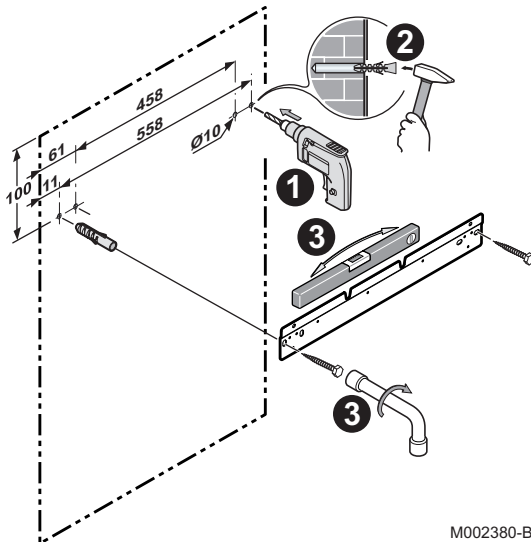

M002380-B

1. Drill 2 holes with a \varnothing of 10 mm.



Additional holes are provided in case one or other of the standard locating holes prevents the correct location of the plugs.

2. Put the plugs in place.
3. Fix the mounting rail to the wall using the hexagonal head screws provided for this purpose. Set the level using a spirit level.

■ Fixing to the wall



CAUTION

Weight (empty): 74 kg
Shipping weight: 112 kg

1. Present the indoor module above the mounting rail until it rests firmly against it.
2. Gently lower the indoor module.

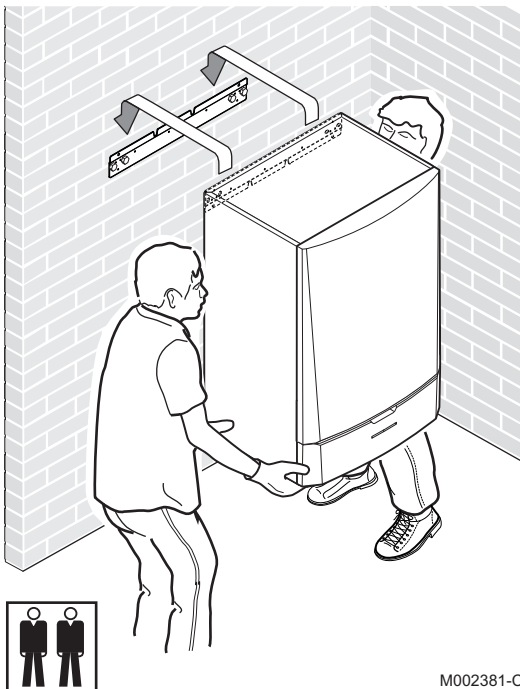

M002381-C

4.6 Installing the outside sensor

4.6.1. Choice of the location

It is important to select a place that allows the sensor to measure the outside conditions correctly and effectively.

Advised positions:

- ▶ on one face of the area to be heated, on the north if possible
- ▶ half way up the wall in the room to be heated
- ▶ under the influence of meteorological variations
- ▶ protected from direct sunlight
- ▶ easy to access

- A** Recommended position
- B** Possible position
- H** Inhabited height controlled by the sensor
- Z** Inhabited area controlled by the sensor

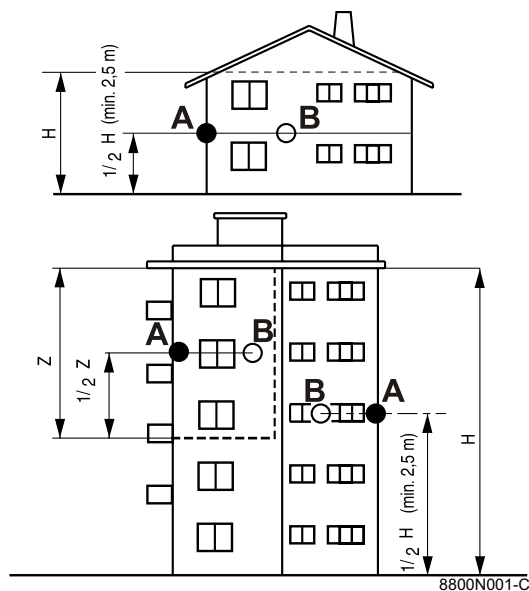

Positions to be avoided:

- ▶ masked by a building element (balcony, roof, etc.)
- ▶ close to a disruptive heat source (sun, chimney, ventilation grid, etc.)

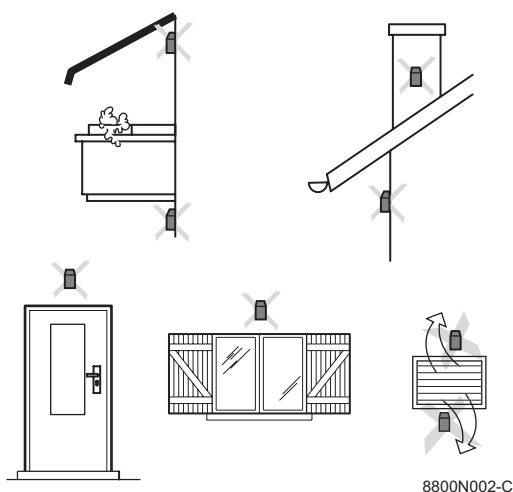

4.6.2. Connecting the outside sensor

Mount the sensor using the screws and dowels provided.

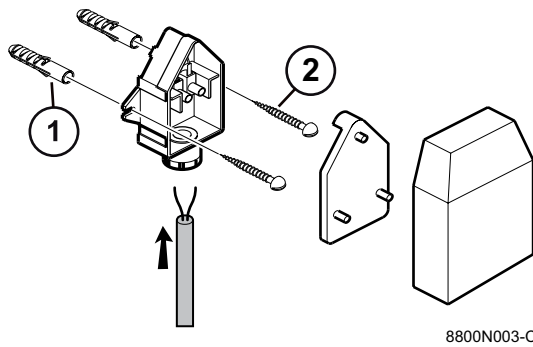

- ① Inserts
② Ø4 wood screw

For the connection of the outside temperature sensor, refer to the chapter "Electrical Connections".

4.7 Combination with a DHW tank

In order to optimise domestic hot water production, the recommended combinations of heat pumps and DHW tanks are:

	4 MR	6 MR-2	8 MR-2	11 MR-TR 2	16 MR-TR 2	22 TR	27 TR
BLC150	X	X	X	X			
BLC200		X	X	X	X		
BLC300				X	X	X	X



WARNING

An incorrect DHW tank/heat pump combination may adversely affect user comfort.



An incorrect combination may lead to overconsumption subsequent to the repeated tripping of the back-ups.

4.8 Installing the refrigerant piping

4.8.1. Installing the pipes



DANGER

Only a qualified professional may carry out the installation in conformity with in force legislation and standards.

- ▶ Install the frigorific connection pipes between the inside and outside modules.
- ▶ Respect the minimum curve radii of 100 to 150 mm.
- ▶ **Only for 22 - 27 TR models:**
If the length of the piping is less than 20 m, it is possible to use annealed pipe for the gas pipe with a diameter of 3/4 without using braze-on adapters. The output in cooling mode may be reduced to 20% depending on the length used.
- ▶ Respect the minimum and maximum lengths. See chapter: "Positioning of the appliance", page 20.
If the frigorific connection between the outside module and the inside module is less than 5 m, the following disruptions may occur:

- Functional disruptions caused by a fluid overload
 - Noise pollution caused by the circulation of the refrigerant
- In this case, fit a refrigerant connection of at least 5 m by making 1 or 2 horizontal loops, as necessary, in order to limit such annoyance and oil traps.
- If the refrigeration connection pipes are more than 10 metres long, refrigerant R410A must be added.

Add refrigerant via the refrigerant shut off valve using a safety loader.

 See chapter: "Adding refrigerant", page 36.

- ▶ Cut the pipes with a pipe cutter and deburr them, point the opening in the pipe downwards to prevent the introduction of particles.
- ▶ Prevent oil traps.



WARNING

If the pipes are not to be connected immediately, they should be plugged to prevent the infiltration of humidity.



Use a flat spanner to hold the hoses during the various operations.

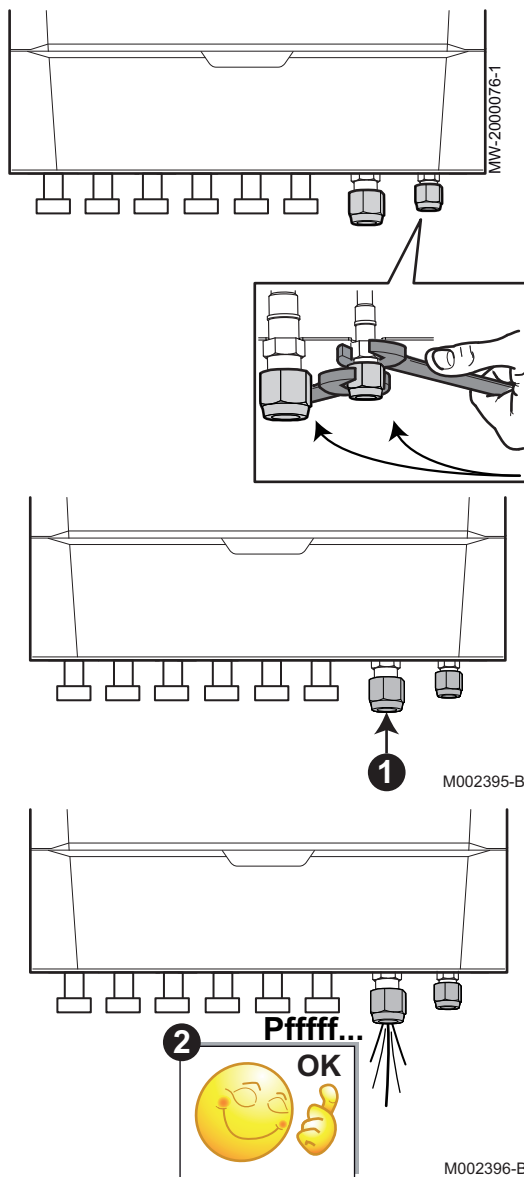

1. Partially unscrew the 5/8" or 3/4" "gas" nut, depending on the model.

2. A release noise should be heard, which is proof that the exchanger is watertight.

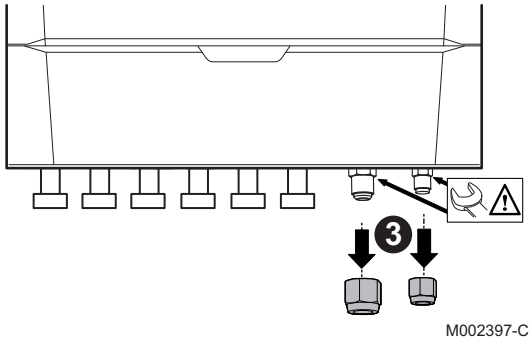

3. Unscrew the screws.



CAUTION

Keep the frigorific connection in place on the MIT-IN-2 with a spanner so as not to twist the internal pipe.

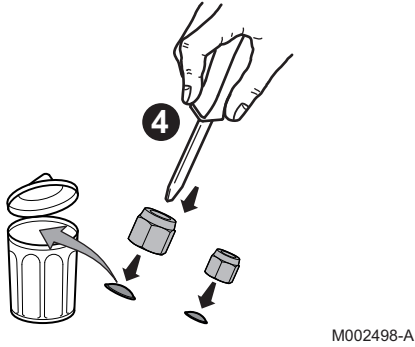

4. Remove and discard the gates.

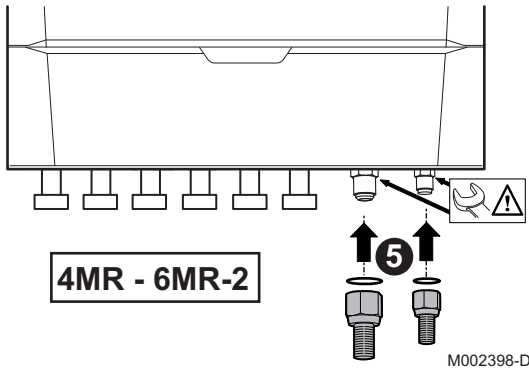

5. **Only for 4 - 6 MR-2 models**

Fit the 1/4" to 3/8" and 1/2" to 5/8" adapter fittings (Package EH146).

Use the copper gaskets.

Use a torque wrench. See "torque" table (step 9).

Only for the 22 TR model

Fit a 3/8" to 1/2" adapter to the liquid connection.

Use the copper gaskets.

Use a torque wrench. See "torque" table (step 9).



CAUTION

Keep the frigorific connection in place on the MIT-IN-2 with a spanner so as not to twist the internal pipe.

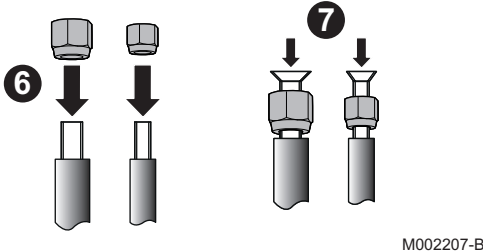
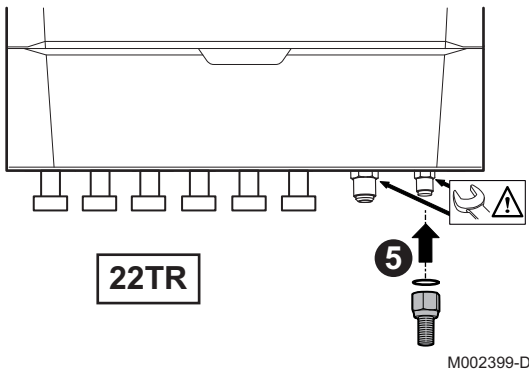

6. **Models 8 to 16 MR/TR-2 and 27 TR**

Slip the nuts onto the pipes.

Models 4 and 6 MR-2 and 22 TR

Slip the nuts provided with the adapters onto the pipes.

7. Bead the pipes.

22TR - 27TR

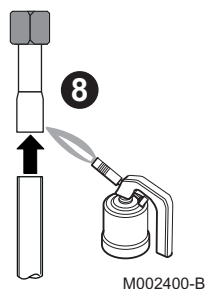

M002400-B

8. Models 22 TR and 27 TR

If the length of the piping is less than 20 m, it is possible to use annealed pipe for the gas pipe with a diameter of 3/4 without using braze-on adapters. The output in cooling mode may be reduced to 20% depending on the length used.

Using the 1" braze-on gas pipe:

Braze the 1" gas pipe on to the braze-on adapter, circulating dehydrated nitrogen inside the pipe to prevent oxidation.



CAUTION

Do not overheat the pipe, protect the insulation and the inside module when brazing.
Use hard solder.

Using the 3/4" crown gas pipe:

Slip the nut onto the pipe. Bead the pipes.

9.

A	Only for 4 - 6 MR-2 models
B	Only for 8 - 11 - 16 MR-2 models
C	Only for 22 TR models
D	Only for 27 TR models

Apply refrigerant oil to the beaded parts to facilitate tightening and improve watertightness. Apply refrigerant oil to the beaded parts to facilitate tightening and improve watertightness.

Connect the pipes and tighten the nuts with a dynamometric spanner.



CAUTION

Keep the frigorific connection in place on the MIT-IN-2 with a spanner so as not to twist the internal pipe.

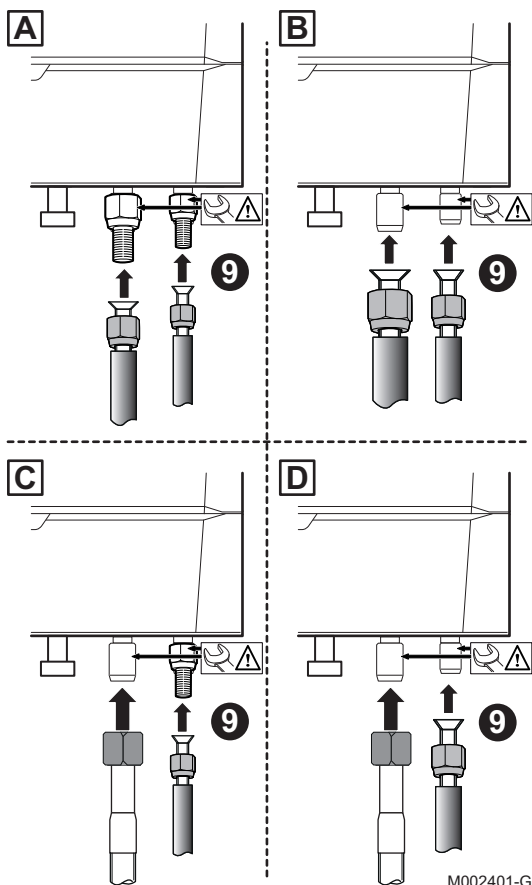

M002401-G

External diameter of the pipe (mm-inch)	External diameter of the cone connection (mm)	Torque load (Nm)
6.35 - 1/4	17	14 - 18
9.52 - 3/8	22	34 - 42
12.7 - 1/2	26	49 - 61
15.88 - 5/8	29	69 - 82
19.05 - 3/4		100 - 120

10. Remove the protective side panels from the outdoor module.

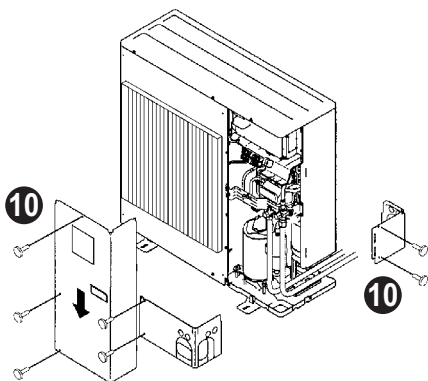

M002402-A

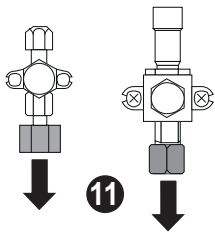

11. Unscrew the nuts on the shut off valves.
12. Slip the nuts onto the pipes.
13. Bead the pipes.

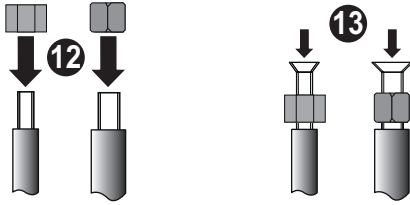

Models 22 and 27 TR (Braze-on 1" fitting): Braze the connecting pipe to the local pipe without oxygen. Braze in a nitrogen atmosphere.

M002403-A

22TR - 27TR

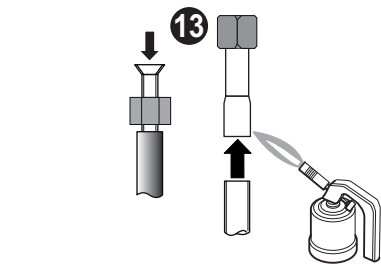
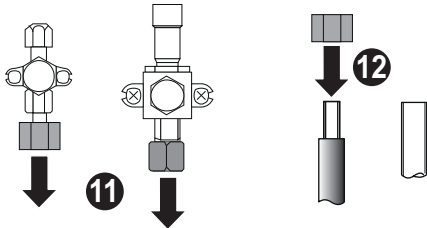

M002405-A

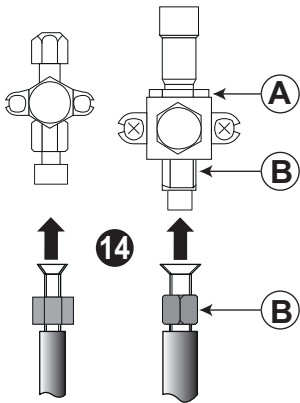

14. Apply refrigerant oil to the beaded parts to facilitate tightening and improve watertightness. Connect the pipes and tighten the nuts with a dynamometric spanner.
 - A** Do not use a spanner on this part of the valve, danger of the refrigerant leaking.
 - B** Recommended position of the spanners for tightening the nut.

CAUTION
Tighten the nuts using a dynamometric spanner.

M002404-A

22TR - 27TR

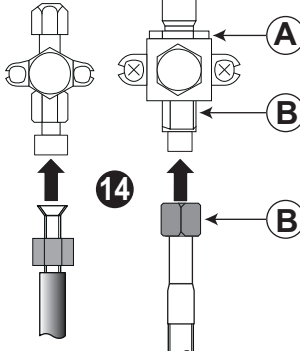

M002406-A

External diameter of the pipe (mm-inch)	External diameter of the cone connection (mm)	Torque load (Nm)
6.35 - 1/4	17	14 - 18
9.52 - 3/8	22	34 - 42
12.7 - 1/2	26	49 - 61
15.88 - 5/8	29	69 - 82
19.05 - 3/4		100 - 120

4.8.2. Water tightness test

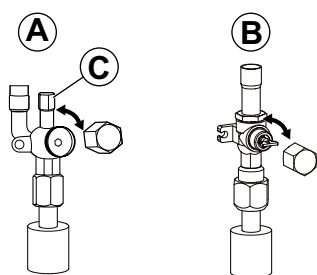

M002297-A

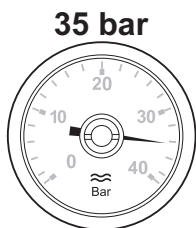

M001470-B

1. Check that the shut off valves **A** and **B** are closed.
2. Connect the pressure gauge valve and the nitrogen cylinder to the operating connection **C** on the shut off valve **A**.
3. Progressively pressurise the refrigerant connection pipes and the indoor module in steps of 5 bar until you reach 35 bar.
4. Check the watertightness of the connections with a "leak detector" spray. If leaks occur, redo and recheck tightness.
5. Release the pressure and release the nitrogen.

4.8.3. Evacuation

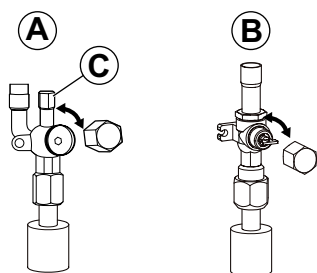

M002297-A



M002499-B

1. Check that the shut off valves **A** and **B** are closed.
2. Connect the vacuum gauge and the vacuum pump to the operating connection **C** and the shut off valve **A**.
3. Produce a vacuum in the indoor module and the refrigerant connection pipes.
4. Check the pressure according to the recommendations table below:

Outside temperature (°C)	≥ 20	10	0	- 10
Pressure to be reached (Pa)	1000	600	250	200
Draw-off evacuation time after reaching the pressure (h)	1	1	2	3

5. Close the valve between the vacuum gauge/vacuum pump and the shut off valve **A**.
6. After shutting off the vacuum pump, immediately open the valves.

4.8.4. Opening the valves

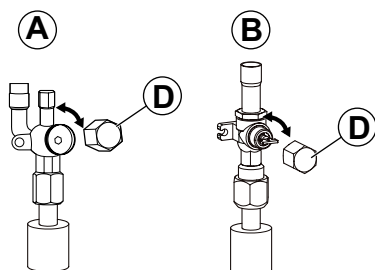

M002295-B

1. Remove the cap **D** on the refrigerant off valve **A**.
2. Open the valve with a hexagonal spanner by turning anti-clockwise until it stops.
3. Put the cap back in place.
4. Remove the cap **D** on the refrigerant gas shut off valve **B**.
5. Open the valve with a pair of pliers, turning it anticlockwise by a quarter turn.
6. Put the cap back in place.
7. Disconnect the vacuum gauge and the vacuum pump. Put the cap back in place.

8. Tighten the caps with a dynamometric spanner with a torque load of 20 to 25 N·m.
9. Check the watertightness of the connections using a leak detector.

4.8.5. Adding refrigerant

If the refrigeration connection pipes are more than 10 metres long, refrigerant R410A must be added. See table below.

Add refrigerant via the refrigerant shut off valve using a safety loader.

Model (Outdoor unit)	Quantity of refrigerant to be added					
	11 to 20 m	21 to 30 m	31 to 40 m	41 to 50 m	51 to 60 m	61 to 75 m
4 - 6 kW	0.2 kg	0.4 kg	0.6 kg	/	/	/
8 kW	0.2 kg	0.4 kg	1.0 kg	/	/	/
11-16 kW	0.2 kg	0.4 kg	1.0 kg	1.6 kg	2.2 kg	2.8 kg
22 kW	0.9 kg	1.8 kg	1.8 kg	1.8 kg	2.7 kg	3.6 kg
27 kw	1.2 kg	2.4 kg	2.4 kg	2.4 kg	3.6 kg	4.8 kg

4.9 Hydraulic connections

 See chapter: "Main dimensions", page 27

4.9.1. Flushing the system

Installation must be carried out in accordance with the prevailing regulations, the codes of practice and the recommendations in these instructions.

Installation must be carried out in accordance with the prevailing regulations, the codes of practice and the recommendations in these instructions.

■ Fitting the appliance to new installations

- ▶ Clean the installation with a universal cleaner to eliminate debris from the system (copper, hemp, flux).
- ▶ Thoroughly flush the installation until the water runs clear and shows no impurities.

■ Fitting the appliance to existing installations



- ▶ Remove sludge from the installation.
- ▶ Flush the installation.
- ▶ Clean the installation with a universal cleaner to eliminate debris from the system (copper, hemp, flux).
- ▶ Thoroughly flush the installation until the water runs clear and shows no impurities.

- ▶ Prior to connection, **rinse the domestic water inlet pipes** so as not to introduce metal or other particles into the DHW coil.

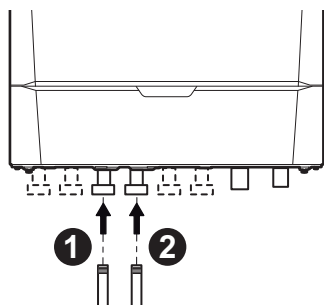
4.9.2. Connection of the heating circuit



M002537-A

1. Connect the heating water return pipe to the heating return connection.
: Screw-on connection \varnothing 1"
2. Connect the heating water outlet pipe to the heating flow connection.
: Screw-on connection \varnothing 1"



- ▶ The device is factory-fitted with a safety valve.



CAUTION

- ▶ The heating pipe must be mounted in accordance with prevailing provisions.

4.9.3. Hydraulic connection diagrams



CAUTION

The maximum volume scheduled for the installation is 215 litres. If this volume is exceeded in relation to the internal expansion vessel, add an external expansion vessel.

■ Example of connecting a system with MIT-IN-2/H

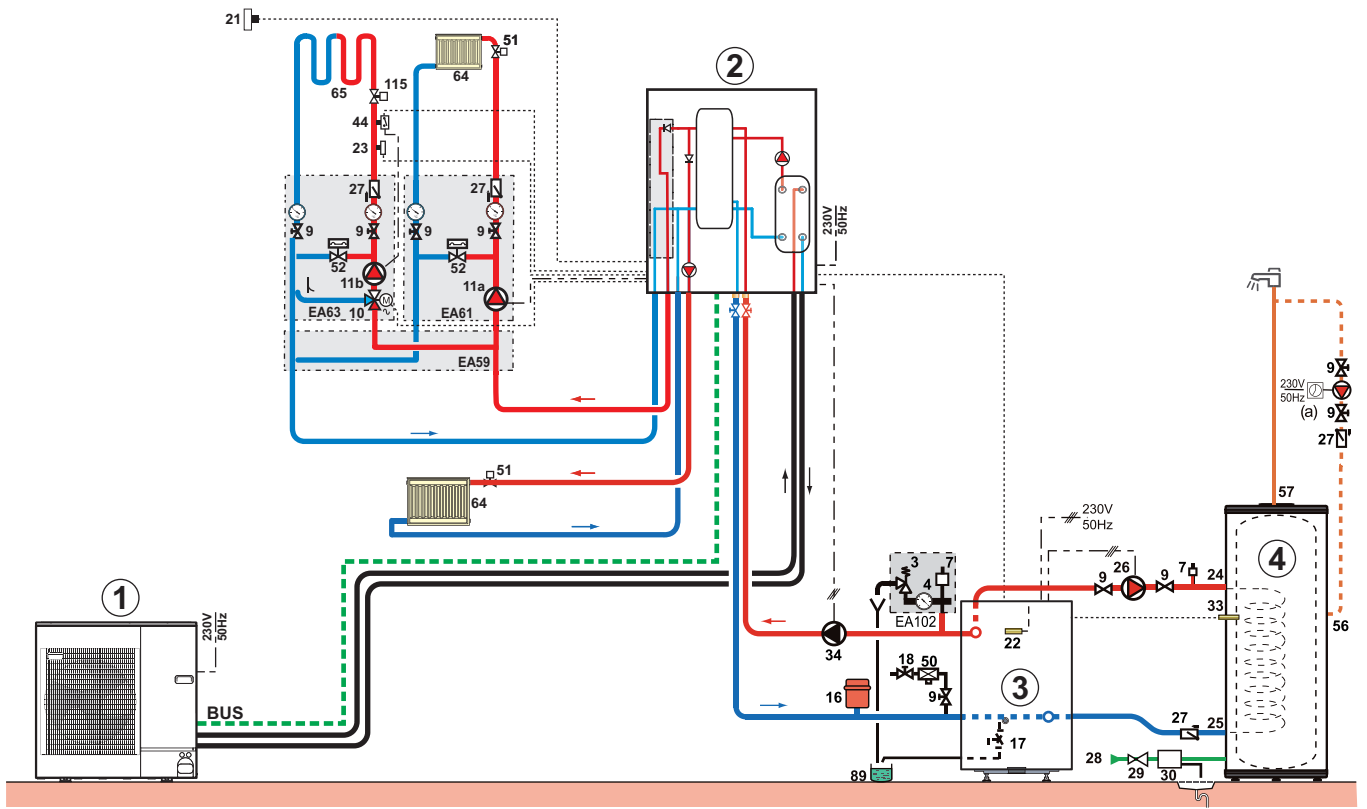

M003026-C

- ① Outdoor unit
- ② Inside module with hydraulic back-up
- ③ boiler back-up
- ④ DHW tank
- 3 3-bar safety valve
- 4 Pressure gauge
- 7 Automatic air vent
- 9 Isolating valve
- 11a Automatically regulated electronic pump for direct heating circuit
- 11b Pump for heating circuit with mixing valve
- 16 Closed expansion vessel
- 17 Drain cock
- 18 Filling the heating circuit
- 21 Exterior temperature sensor
- 22 Boiler temperature sensor
- 23 Mixing valve outlet temperature sensor
- 24 DHW calorifier exchanger primary inlet
- 25 DHW calorifier heat exchanger primary outlet
- 26 DHW load pump
- 27 Non-return valve

- 28 Domestic cold water inlet
- 29 Pressure reducer if supply pressure exceeds 80 % of the safety valve pressure setting
- 30 Calibrated and sealed safety unit
- 33 Domestic hot water temperature sensor
- 34 Primary pump
- 44 Safety thermostat
- 50 Disconnecter
- 51 Thermostat valve
- 52 Differential valve
- 56 Domestic hot water circulation loop return
- 57 Domestic hot water outlet
- 64 Direct heating circuit
- 65 Heating circuit with mixing valve
- 89 Heat transfer fluid container
- 115 Thermostatic distribution valve for each zone

■ Example of connecting a system with MIT-IN-2/E

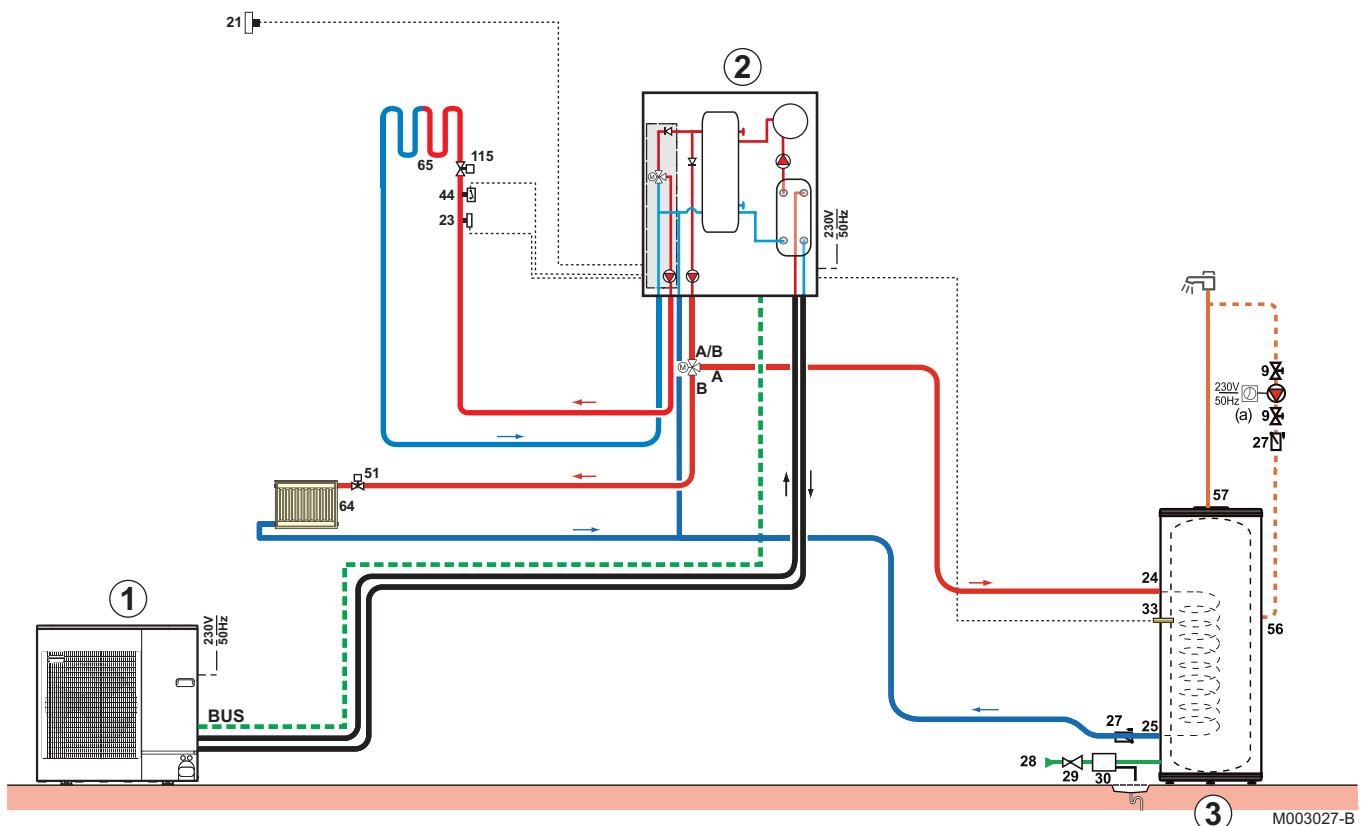

- ① Outdoor unit
- ② Inside module with electrical back-up
- ③ DHW tank
- 3 3-bar safety valve

4	Pressure gauge
7	Automatic air vent
9	Isolating valve
11a	Automatically regulated electronic pump for direct heating circuit
11b	Pump for heating circuit with mixing valve
16	Closed expansion vessel
17	Drain cock
18	Filling the heating circuit
21	Exterior temperature sensor
22	Boiler temperature sensor
23	Mixing valve outlet temperature sensor
24	DHW calorifier exchanger primary inlet
25	DHW calorifier heat exchanger primary outlet
26	DHW load pump
27	Non-return valve
28	Domestic cold water inlet
29	Pressure reducer if supply pressure exceeds 80 % of the safety valve pressure setting
30	Calibrated and sealed safety unit
33	Domestic hot water temperature sensor
34	Primary pump
44	Safety thermostat
50	Disconnecter
51	Thermostat valve
52	Differential valve
56	Domestic hot water circulation loop return
57	Domestic hot water outlet
64	Direct heating circuit
65	Heating circuit with mixing valve
89	Heat transfer fluid container
115	Thermostatic distribution valve for each zone

4.10 Filling the heating system

4.10.1. Water treatment in the heating circuit

In a number of cases, the heat pump and the central heating system can be filled with normal tap water and no water treatment is necessary.

**WARNING**

- ▶ Do not add chemical products to the central heating water without first consulting a water treatment professional. For example: antifreeze, water softeners, products to increase or reduce the pH value, chemical additives and/or inhibitors. Chemical products may cause malfunctions on the heat pump and damage the heat exchanger.
- ▶ Do not use hydrochloric acid-based cleaning or descaling products.

**CAUTION**

- ▶ Check the compatibility of the product with the materials used in the installation.
- ▶ Check the compatibility of the product with stainless steel and copper.
- ▶ Respect the manufacturer's instructions (use, dose, etc.) to obviate any hazards (corporal, material, environmental).
- ▶ An uncleaned installation or an installation using water of unsuitable quality may bring about the cancellation of the warranty.



- ▶ Flush the central heating installation with at least 3x the volume of the central heating installation.
- ▶ Flush the DHW pipes with at least 20 times the volume of the pipes.

For an optimum functioning of the boiler, the water of the installation must comply with following characteristics:

		Output ≤ 70 kW
Acidity (pH)		7.5 - 9
Conductivity at 25°C	μS/cm	10 to 500
Chlorides	mg/l	< 50
Other components	mg/l	< 1
Hardness of the water of the installation	°f	7- 15
	°dH	4- 8.5



If a water treatment is necessary, **De Dietrich Thermique** recommends the following manufacturers:

- ▶ Cillit
- ▶ Climalife
- ▶ Fernox
- ▶ Permo
- ▶ Sentinel

4.10.2. Filling the system



CAUTION

Do not use glycol.
The heat pump components are not designed to be used with glycol.
The use of glycol in the heating circuit invalidates the warranty.

- ▶ Fill the installation until a pressure of 1.5 to 2 bars is reached.
Water pressure display: See chapter:  "Reading out measured values", page 94.
- ▶ Check for any water leaks.
- ▶ Completely vent any air in the inside module and the installation for optimum running.

4.11 Electrical connections

4.11.1. Recommendations



WARNING

- ▶ Only qualified professionals may carry out electrical connections, always with the power off.
- ▶ Earth the appliance before making any electrical connections.

Make the electrical connections of the appliance according to:

- ▶ The instructions of the prevailing standards,
- ▶ The instructions on the circuit diagrams provided with the appliance,
- ▶ The manufacturer's instructions.

The earthing shall comply with local standards.



CAUTION

- ▶ Separate the sensor cables from the 230/400 V circuit cables.
- ▶ The installation must be fitted with a circuit breaker disconnecting switch.
- ▶ Three phase models must always be fitted with neutral.

Power the appliance via a circuit which includes a remote omnipolar switch with a gap of more than 3 mm.

- ▶ Single phase models: 230 V AC (+6%/-10%) 50 Hz
- ▶ Three phase models: 400 V AC (+6%/-10%) 50 Hz

When making electrical connections to the mains, respect the following polarities:

- ▶ Brown wire: Live
- ▶ Blue wire: Neutral
- ▶ Green/yellow wire: Earth



WARNING

Secure the cable with the cable clamp provided. Be careful that you do not invert the wires.

4.11.2. Recommended cable cross section

The electrical characteristics of the mains power supply available must correspond to the values given on the rating plate.

The cable will be carefully chosen according to the following information:

- ▶ Maximum intensity of the outdoor module. See table below.
- ▶ Distance of the appliance from the original power supply.
- ▶ Upstream protection.
- ▶ Neutral operating conditions.

Appliance	AWHP MIT-IN-2	4 MR	6 MR-2	8 MR-2	11 MR-2	11 TR-2	16 MR-2	16 TR-2	22 TR	27 TR	
Outdoor unit	Absorbed electrical power	kW	1.50	1.50	2.10	2.59	2.59	4.03	4.03	5.6	6.9
	Nominal amperage	A	6.8	6.8	9.34	11.2	3.98	17.7	5.99	13.9	17.2
	Maximal amperage	A	13	13	19	28	13	29	13	19	21
	Type ⁽¹⁾		1 ~	1 ~	1 ~	1 ~	3 ~	1 ~	3 ~	3 ~	3 ~
	Power supply	S-C ⁽²⁾	3 x 2.5	3 x 2.5	3 x 4	3 x 6	5 x 2.5	3 x 10	5 x 2.5	5 x 4	5 x 6
Curve D DJ ⁽³⁾		16 A	16 A	25 A	32 A	16 A	40 A	16 A	25 A	32 A	
Indoor module	Power supply	S-C ⁽²⁾	3 x 1.5	3 x 1.5	3 x 1.5	3 x 1.5	3 x 1.5	3 x 1.5	3 x 1.5	3 x 1.5	3 x 1.5
		Curve C DJ ⁽³⁾	10 A	10 A	10 A	10 A	10 A	10 A	10 A	10 A	10 A
Cable BUS ⁽⁴⁾		S-C ⁽²⁾	3 x 1.5	3 x 1.5	3 x 1.5	3 x 1.5	3 x 1.5	3 x 1.5	3 x 1.5	3 x 1.5	3 x 1.5

(1) 1 ~ : Single phase, 3 ~ : Three-phase
(2) Cable cross section (mm²)
(3) Circuit breaker
(4) Connection cable between outdoor and indoor module

■ Connecting the electrical back-up

Type	S-C ⁽¹⁾	Curve C DJ ⁽²⁾
Single phase	3 x 6	32 A
Three-phase	5 x 4	25 A

(1) Cable cross section (mm²)
(2) Circuit breaker

4.11.3. Accessing the connection terminal blocks

■ Outdoor unit

Only for 4, 6 kW models

1. Unscrew the holding screws.
2. Remove the protection cap.

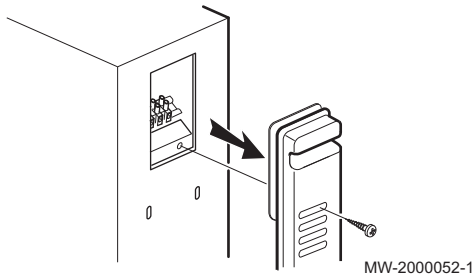

Only for 8, 11, 16, 22, 27 kW models

1. Unscrew the holding screws.
2. Remove the protection cap.

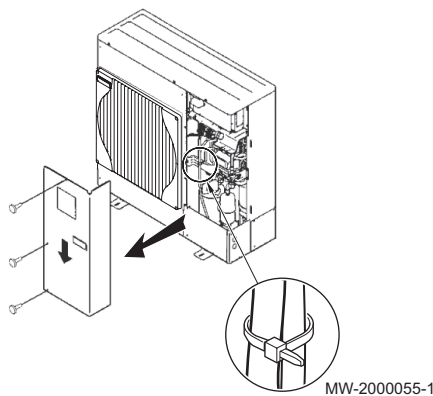

CAUTION

Secure the cables with cable clamps to obviate any contact with the centre of the protective cover or the gas valve.

■ Indoor module

To access the connection terminal blocks, proceed as follows:

1. Unscrew the 2 screws under the front panel by a quarter turn.

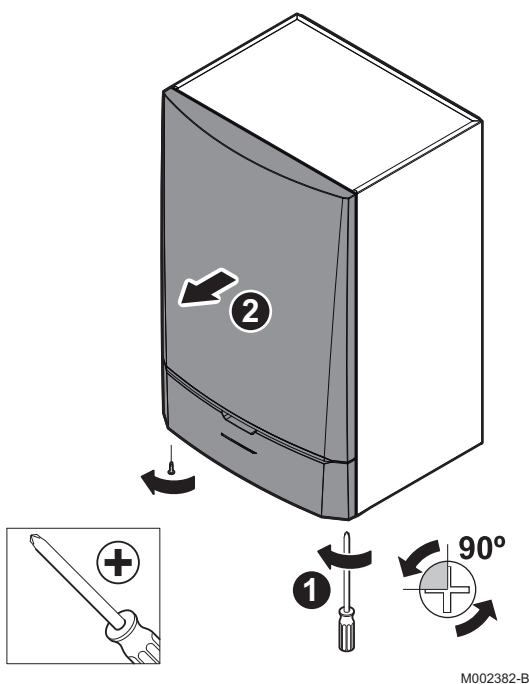

2. Remove the front panel.
3. Open the holding clips located on the sides.
4. Tilt the control panel forwards.

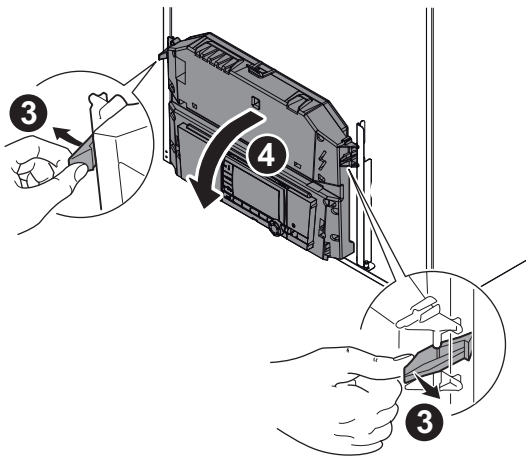

M002383-B

5. Lift the clip located in front of the control panel.
6. Lift the control panel cover.

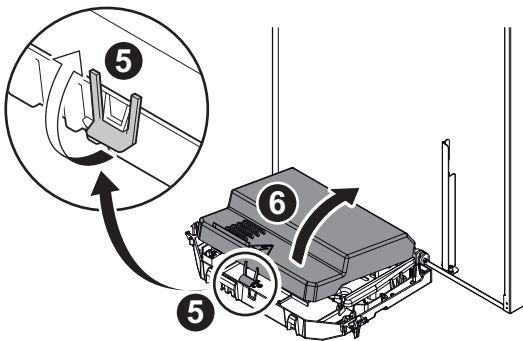

M002491-A

7. Unclip the PCB cover.

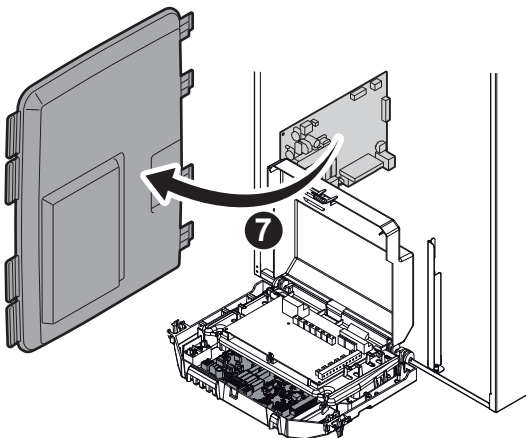

M002492-A

4.11.4. Position of the PCBs

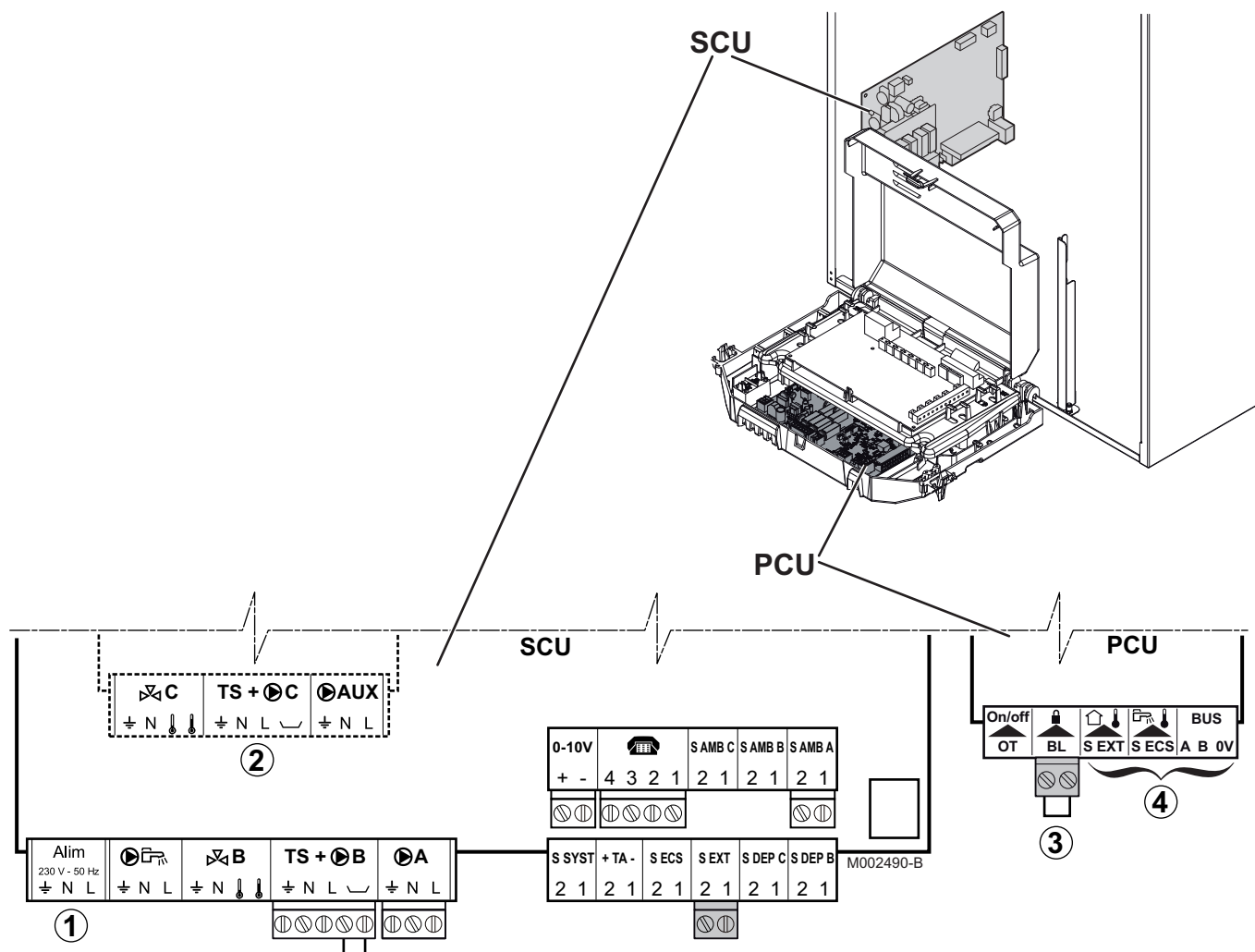

- ① Do not connect anything to the terminal block.
- ② Optional PCB (Package AD249)
- ③ The BL inlet must always be connected to a dry contact (potential-free).
- ④ Do not connect anything to the terminal block.

4.11.5. Location of the fuse

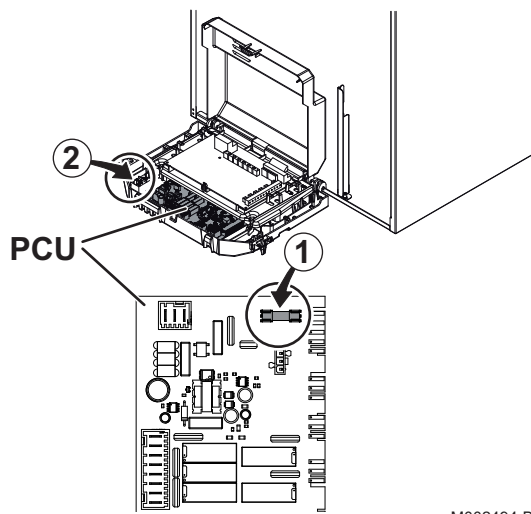

- ① F1 6,3 AT fuse 250 V AC
- ② Spare fuse

M002494-B

4.11.6. Connecting the outdoor module

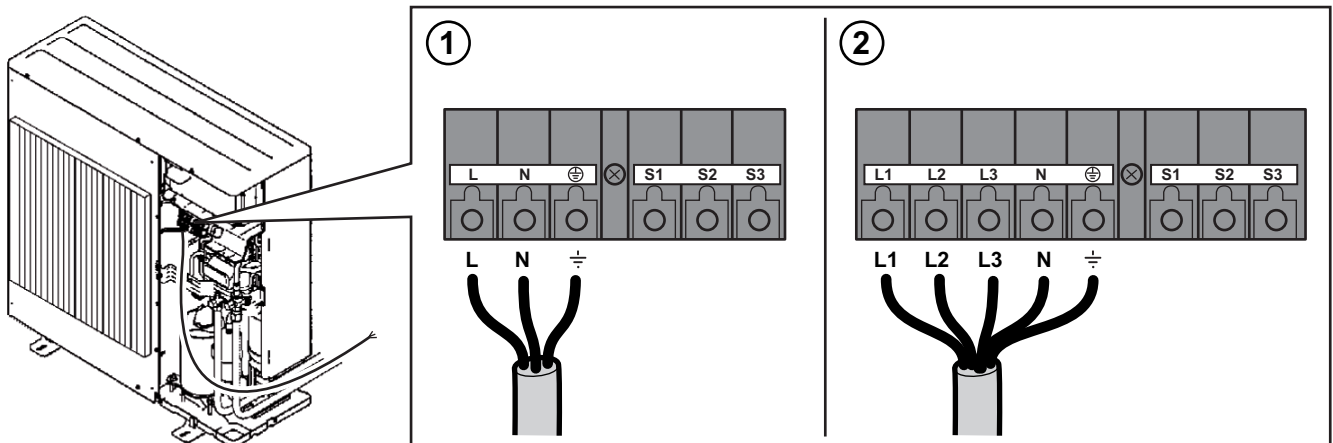

M001478-B

- ① Single phase power supply
- ② Three-phase power supply

4.11.7. Connecting the communication cable between the inside and outside modules

Communication cable liaison: 3 x 1.5 mm²



Cable to be supplied by the installer.

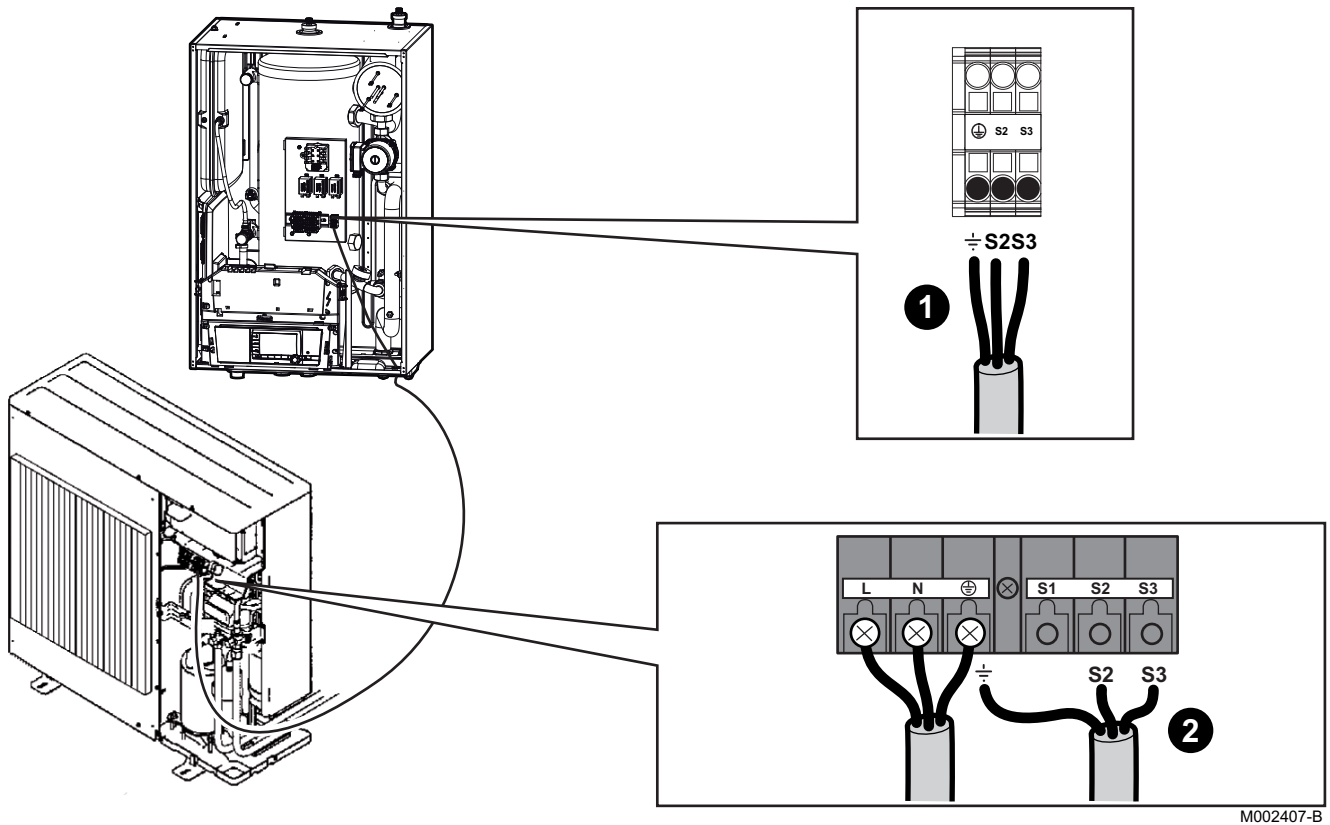

M002407-B

⚠ WARNING
Be careful that you do not invert the wires.

- ① Connect to terminals S2, S3 and \perp .
- ② Connect to terminals S2, S3 and \perp . (Outdoor unit)

4.11.8. Description of the terminal block on the inside module

■ Inside module with hydraulic back-up

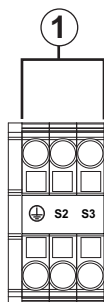

M002410-B

- ① Bus for communication with the outside module

■ Inside module with electrical back-up

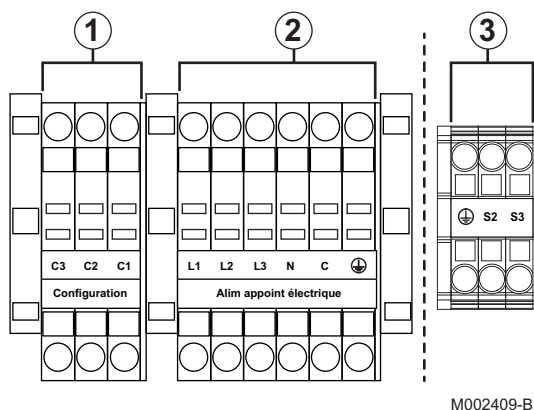

- ① Output configuration of electric back-ups
- ② Auxiliary electrical power supply
- ③ Bus for communication with the outside module

M002409-B

4.11.9. Connecting the mains supply to the inside module

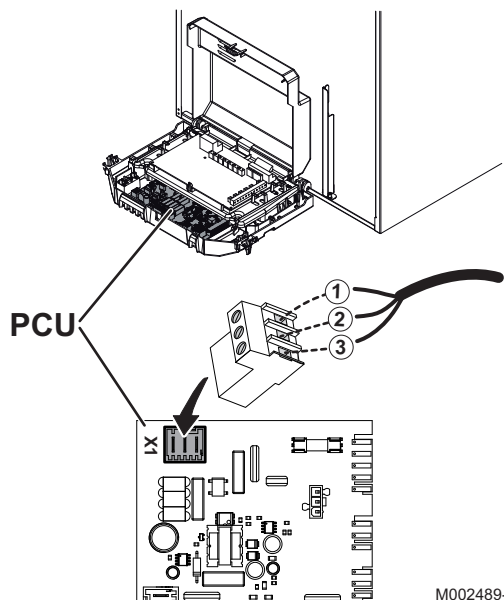

- ① L (Live: Brown)
- ② N (Neutral: Blue)
- ③ ⚡ (Earth: Green/yellow wire)
- X1 Power connector



CAUTION

The earth conductor must be longer than the live and neutral conductors.



CAUTION

Use the cable clamps provided in the instructions bag.

M002489-C

4.11.10. Connecting the electrical back-up to the inside module

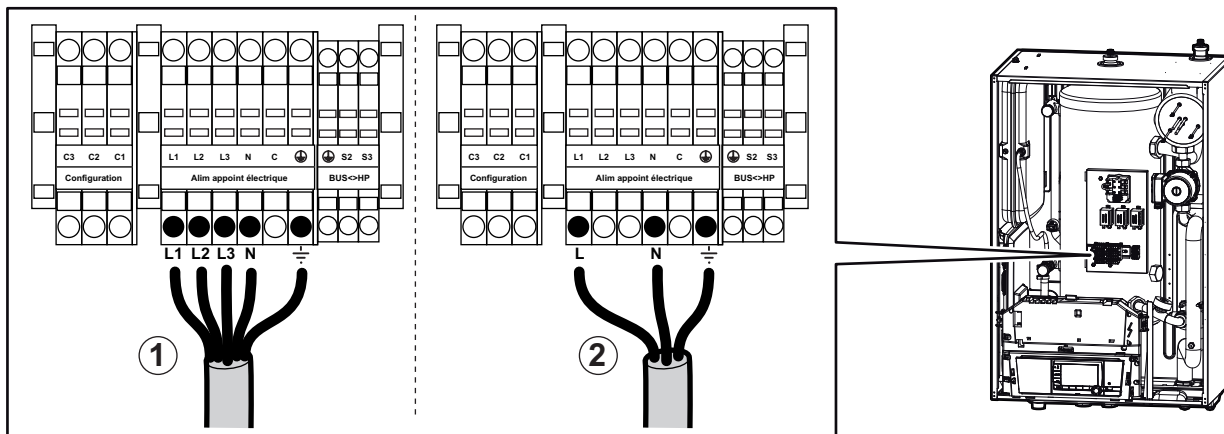

M002408-D

- ① Three-phase power supply: 400 V AC

② Single phase power supply: 230 V AC



CAUTION

The earth conductor must be longer than the live and neutral conductors.

■ **Fitting the jumpers and bridges**

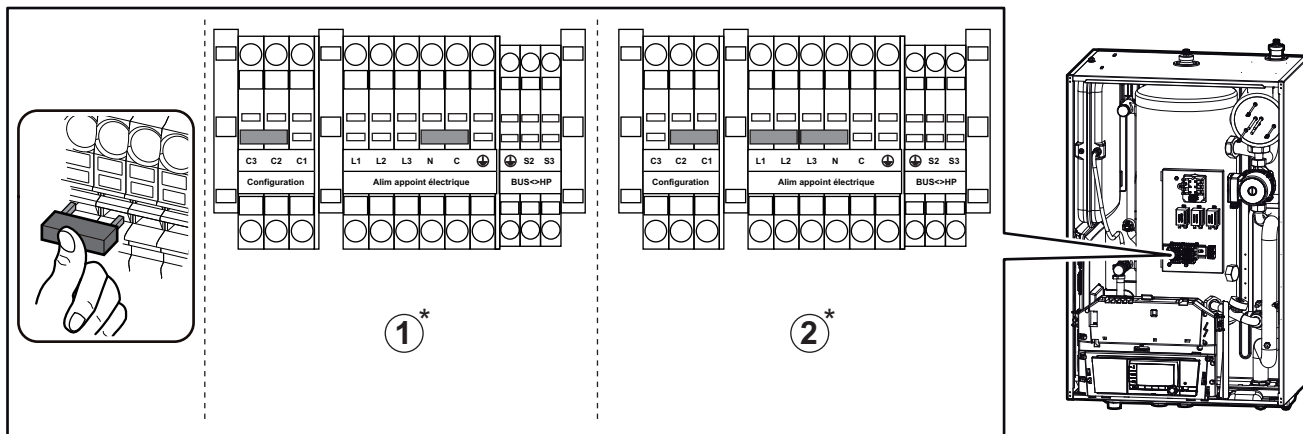

M002393-E

① Three-phase

② Single phase

* For the various options for setting the bridge, see the paragraph below, "Setting the output".



CAUTION

Check that the clips are correctly connected to the tab as poor contact may lead to the connection overheating.

■ **Output control**

👉 For setting the **BACKUP TYPE** parameter, see: "Professional settings", page 98

Type	BACKUP TYPE setting	Back-up	Output	Bridge
Single phase	/E2	Stage 1	2 kW	between C2 and C1
		Stage 2	4 kW	
		Stage 1 + 2	6 kW	
	/E1	Stage 1	2 kW	

Type	BACKUP TYPE setting	Back-up	Output	Bridge
Three-phase	/E2	Stage 1	4 kW	between C3 and C2
		Stage 2	8 kW	
		Stage 1 + 2	12 kW	
		Stage 1	8 kW	between C2 and C1
		Stage 2	4 kW	
		Stage 1 + 2	12 kW	
	/E1	Stage 1	8 kW	between C2 and C1
			4 kW	Remove bridge
			4 kW	Remove bridge

4.11.11. Connecting the hydraulic auxiliary on the inside module



WARNING

Respect the polarity of the terminals: Live (P), neutral (N), and earth (\perp).

- ① Back-up pump
- ② Burner (Volt free contact)

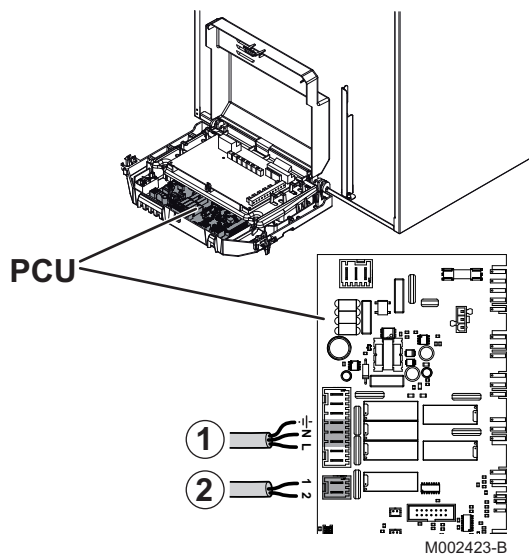





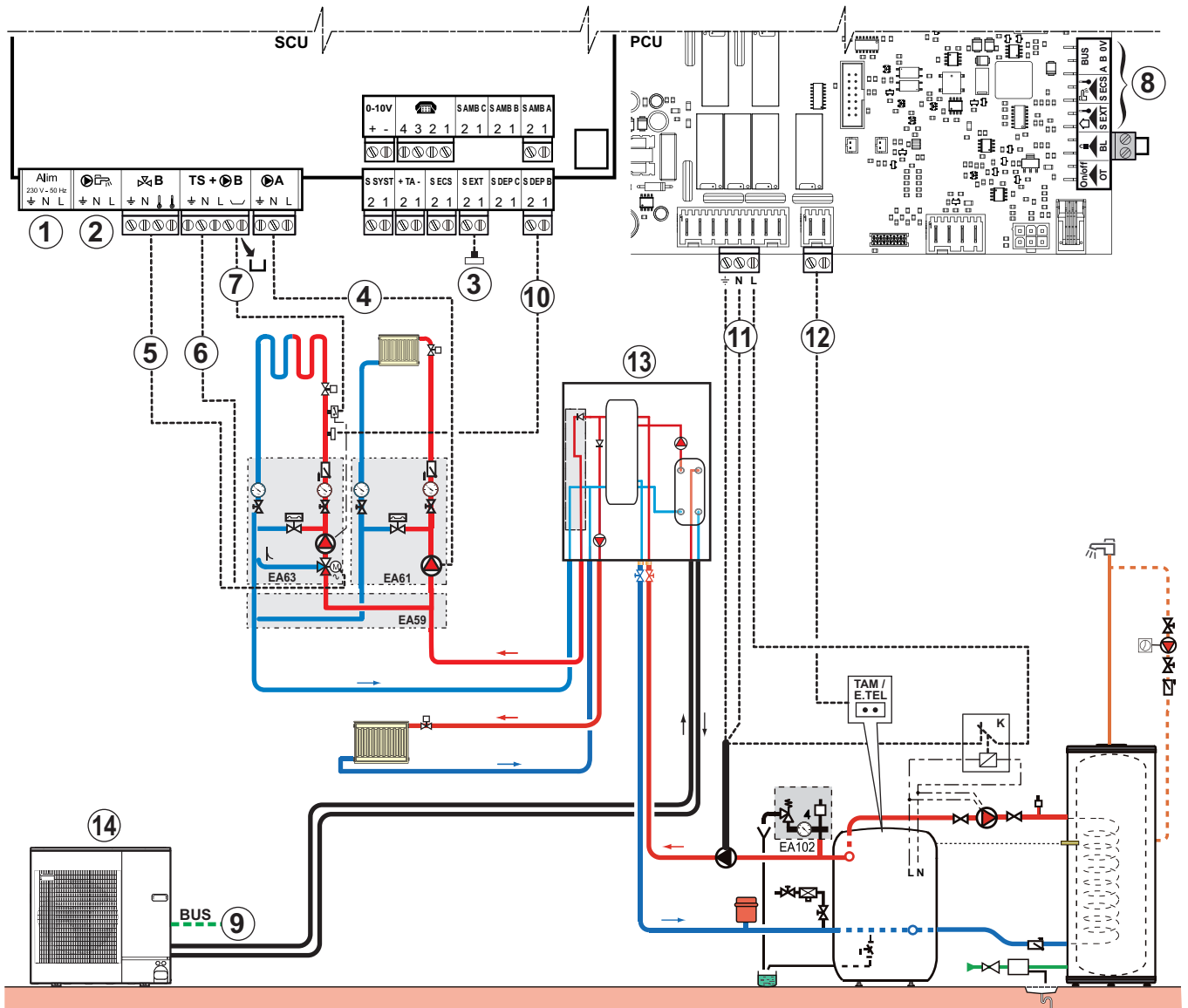



4.11.12. Connection example for a system with hydraulic back-up

- Boiler fitted with a control panel with a TAM and/or I.TEL input



- ① Not used: Do not connect anything to the terminal block.
- ②  **CAUTION**
Do not connect anything to the DHW pump outlet.
- ③ Connect the outside temperature sensor.
- ④ Connect the heating pump (Circuit A).
- ⑤ Connect the 3-way valve motor (Circuit B).
- ⑥ Connect the heating pump (Circuit B).

- ⑦ Connect a safety thermostat if the heating circuit is for underfloor heating: Remove the bridge. Connect the wires from the safety thermostat to the connector.
- ⑧ Not used: Do not connect anything to the terminal block.
- ⑨ Connect the BUS cable between the outside module and the terminal block on the inside module.
- ⑩ Connect the outlet sensor (Circuit B).
- ⑪ Connect the heating pump and the K relays to the AL1 connector on the PCU PCB.
- ⑫ Connect the boiler's room thermostat to the AL2 connector on the PCU PCB.
- ⑬ Inside module with hydraulic back-up
- ⑭ Outdoor unit

Settings to be made on the inside module for this type of installation			
Parameters	Access	Settings to be made	See chapter
INSTALLATION	Installer level #SYSTEM menu	EXTENDED	 "Displaying the parameters in extended mode", page 84
O.PUMP A ⁽¹⁾	Installer level #SYSTEM menu	CH.PUMP A	 "Setting the parameters specific to the installation", page 86
CIRC.A ⁽¹⁾	Installer level #SYSTEM menu	DIRECT	 "Setting the parameters specific to the installation", page 86
PUMP MIT/MHR	Installer level #SYSTEM menu	CIRC.A	 "Setting the parameters specific to the installation", page 86
CIRC.B ⁽¹⁾	Installer level #SYSTEM menu	3WV	 "Setting the parameters specific to the installation", page 86
CIRC.CURVE A	Installer level #SECONDARY INSTAL.P menu	1.5	 "Professional settings", page 98
CIRC.CURVE B	Installer level #SECONDARY INSTAL.P menu	0.7	 "Professional settings", page 98
HP BUS	Installer level #PRIMARY INSTAL.P menu	TOR	 "Professional settings", page 98
BACKUP TYPE	Installer level #PRIMARY INSTAL.P menu	/H	 "Professional settings", page 98

(1) The parameter is only displayed if **INSTALLATION** parameter is set to **EXTENDED**

Setting the back-up boiler



The setting of the back-up boiler depends on its type of control panel.

► Diematic 3

Set the following installer settings on the boiler control panel:

- **I.TEL: THERM A**
- **HCZP D / HCZP N**: same value as the parameter **HEAP MAX**: on the Diematic iSystem control panel on the MIT.
- **CIRC.CURVE A**: 0.0
- **OUT.ANTIFREEZE**: -8 °C

Access to parameters:

- Press the  key for 5 seconds.
- Press the  key 2 times.
- Use key  to select the desired parameter.

- ▶ **SVmatic**
Heating temperature setting = **HEAP MAX:**.
- ▶ **B control panel**
Set the boiler thermostat to the same value as **HEAP MAX:**.
- ▶ **Other**
Heating temperature setting = **HEAP MAX:**.

Operating principle

- ▶ **No back-up requested:**
The boiler continues to provide DHW. Contacts AL1 and AL2 are both open.
- ▶ **Back-up requested:**
The AL2 contact closes.
The AL1 outlet is powered up: If the boiler is in domestic hot water mode, the back-up pump is not tripped as the K relay is open. The back-up pump is tripped when the domestic hot water load pump stops.



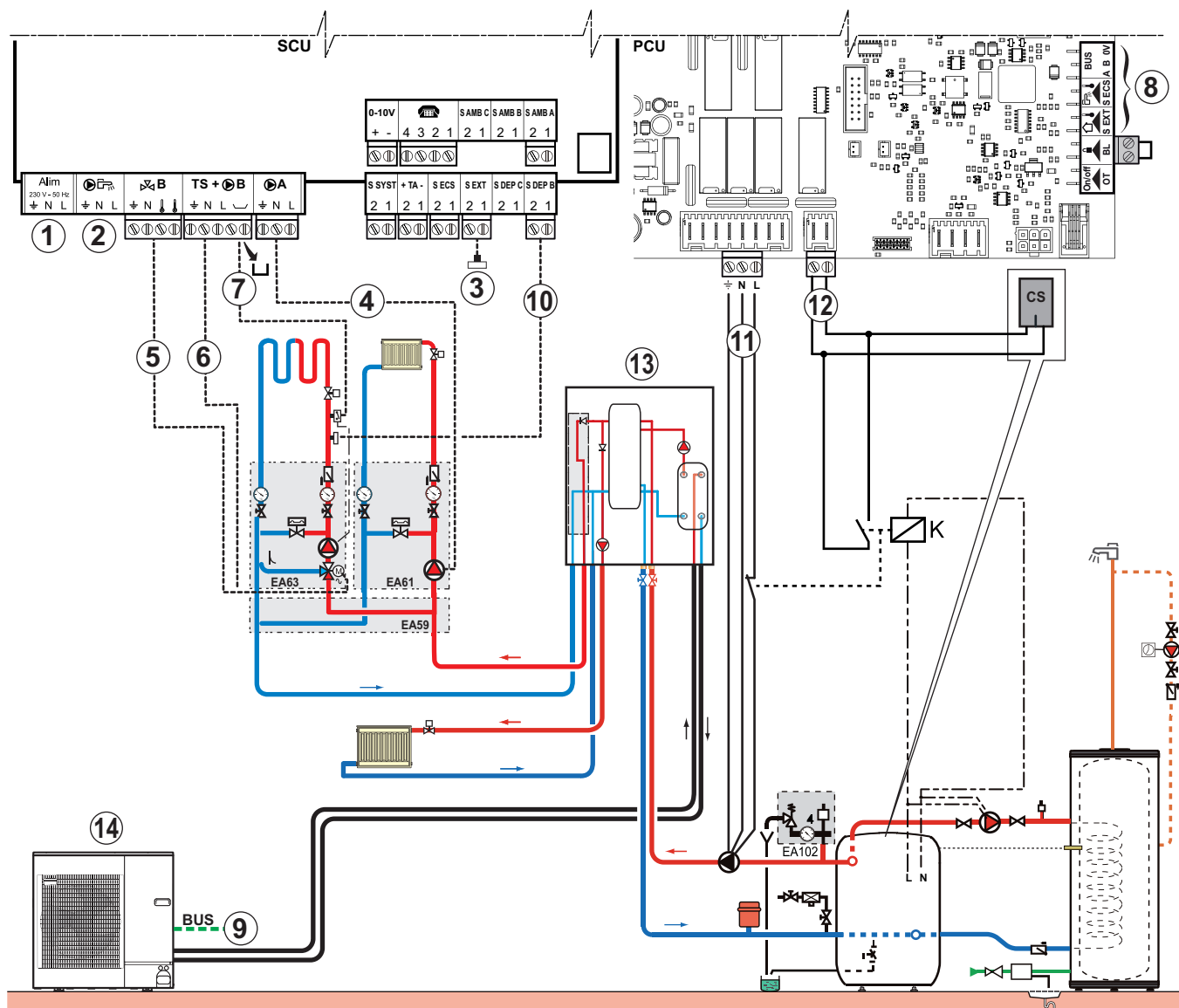





■ Boiler fitted with a control panel without TAM input (Modulating room thermostat)



M003033-B

- ① Not used: Do not connect anything to the terminal block.
- ② **CAUTION**
Do not connect anything to the DHW pump outlet.
- ③ Connect the outside temperature sensor.
- ④ Connect the heating pump (Circuit A).
- ⑤ Connect the 3-way valve motor (Circuit B).
- ⑥ Connect the heating pump (Circuit B).
- ⑦ Connect a safety thermostat if the heating circuit is for underfloor heating: Remove the bridge. Connect the wires from the safety thermostat to the connector.
- ⑧ Not used: Do not connect anything to the terminal block.

- ⑨ Connect the BUS cable between the outside module and the terminal block on the inside module.
- ⑩ Connect the outlet AD 199 sensor (Circuit B).
- ⑪ Connect the heating pump and the K relays to the AL1 connector on the PCU PCB.
- ⑫ Connect the boiler's inlet CS to the AL2 connector on the PCU PCB.
- ⑬ Inside module with electrical back-up
- ⑭ Outdoor unit

Settings to be made on the inside module for this type of installation			
Parameters	Access	Settings to be made	See chapter
INSTALLATION	Installer level #SYSTEM menu	EXTENDED	 "Displaying the parameters in extended mode", page 84
O.PUMP A ⁽¹⁾	Installer level #SYSTEM menu	CH.PUMP A	 "Setting the parameters specific to the installation", page 86
CIRC.A ⁽¹⁾	Installer level #SYSTEM menu	DIRECT	 "Setting the parameters specific to the installation", page 86
PUMP MIT/MHR	Installer level #SYSTEM menu	CIRC.A	 "Setting the parameters specific to the installation", page 86
CIRC.B ⁽¹⁾	Installer level #SYSTEM menu	3WV	 "Setting the parameters specific to the installation", page 86
CIRC.CURVE A	Installer level #SECONDARY INSTAL.P menu	1.5	 "Professional settings", page 98
CIRC.CURVE B	Installer level #SECONDARY INSTAL.P menu	0.7	 "Professional settings", page 98
HP BUS	Installer level #PRIMARY INSTAL.P menu	TOR	 "Professional settings", page 98
BACKUP TYPE	Installer level #PRIMARY INSTAL.P menu	/H	 "Professional settings", page 98

(1) The parameter is only displayed if **INSTALLATION** parameter is set to **EXTENDED**

Setting the back-up boiler

- ▶ Switch the boiler control system to 24h/24 comfort mode.
- ▶ Heating temperature setting = **HEAP MAX**:

Operating principle

- ▶ **In DHW production:**
The relay K closes the contact CS to enable the burner to start up.
- ▶ **In auxiliary heater mode:**
The MIT-2 module controls input CS on the boiler and the back-up pump.
When back-up is requested, the boiler continues to handle DHW priority.
After the back-up is shut down, the back-up pump continues to run during the timed period **BACKUP PUMP DEL.** which can be adjusted in the **#HEAT PUMP** menu.

4.11.13. Connection example for a system with electrical back-up

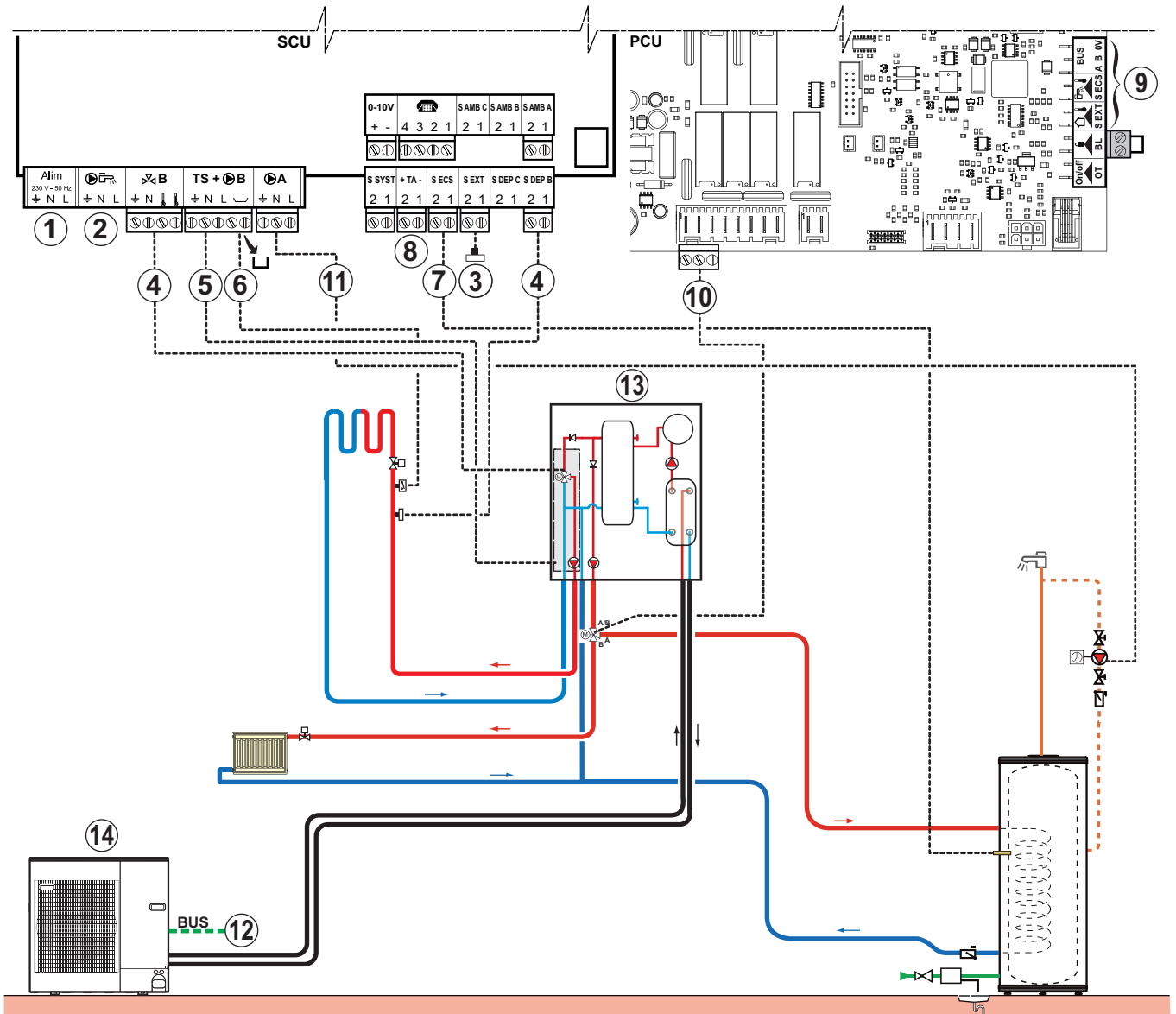



M003034-B











- ① Not used: Do not connect anything to the terminal block.
- ② **CAUTION**
Do not connect anything to the DHW pump outlet as the reversal valve is connected to the PCU PCB in the boiler.
- ③ Connect the outside temperature sensor.
- ④ Connect the 3-way valve motor (circuit B) and the circuit B flow sensor.
- ⑤ Connect the heating pump (Circuit B).
- ⑥ Connect a safety thermostat if the heating circuit is for underfloor heating: Remove the bridge. Connect the wires from the safety thermostat to the connector.
- ⑦ Connect the DHW sensor.

⑧ Connect the DHW tank anode.

 **CAUTION**

- ▶ If the tank is fitted with a Titan Active System® impressed current anode, connect the anode to the inlet (+ TA on the anode, - on the tank).
- ▶ If the tank is not fitted with an impressed current anode, put the simulation connector in place (delivered with the DHW sensor - package AD212).

- ⑨ Not used: Do not connect anything to the terminal block.
- ⑩ Connect the motor on the DHW reversal valve.
- ⑪ Connect the domestic hot water looping pump to the  outlet.
- ⑫ Connect the BUS cable between the outside module and the terminal block on the inside module.
 "Connecting the communication cable between the inside and outside modules", page 47.
- ⑬ Inside module with electrical back-up
- ⑭ Outdoor unit

Settings to be made for this type of installation			
Parameters	Access	Settings to be made	See chapter
INSTALLATION	Installer level #SYSTEM menu	EXTENDED	 "Displaying the parameters in extended mode", page 84
O.PUMP A ⁽¹⁾	Installer level #SYSTEM menu	DHW LOOP	 "Setting the parameters specific to the installation", page 86
CIRC.A ⁽¹⁾	Installer level #SYSTEM menu	DIRECT	 "Setting the parameters specific to the installation", page 86
PUMP MIT/MHR	Installer level #SYSTEM menu	CIRC.A	 "Setting the parameters specific to the installation", page 86
CIRC.B ⁽¹⁾	Installer level #SYSTEM menu	3WV	 "Setting the parameters specific to the installation", page 86
CIRC.CURVE A	Installer level #SECONDARY INSTAL.P menu	1.5	 "Professional settings", page 98
CIRC.CURVE B	Installer level #SECONDARY INSTAL.P menu	0.7	 "Professional settings", page 98
HP BUS	Installer level #PRIMARY INSTAL.P menu	TOR	 "Professional settings", page 98
BACKUP TYPE	Installer level #PRIMARY INSTAL.P menu	/E1 (Stage 1) /E2 (Stage 2)	 "Professional settings", page 98
DHW TYPE	Installer level #PRIMARY INSTAL.P menu	SECONDARY	 "Professional settings", page 98

(1) The parameter is only displayed if INSTALLATION parameter is set to EXTENDED

4.11.14. Connection example in cooling mode

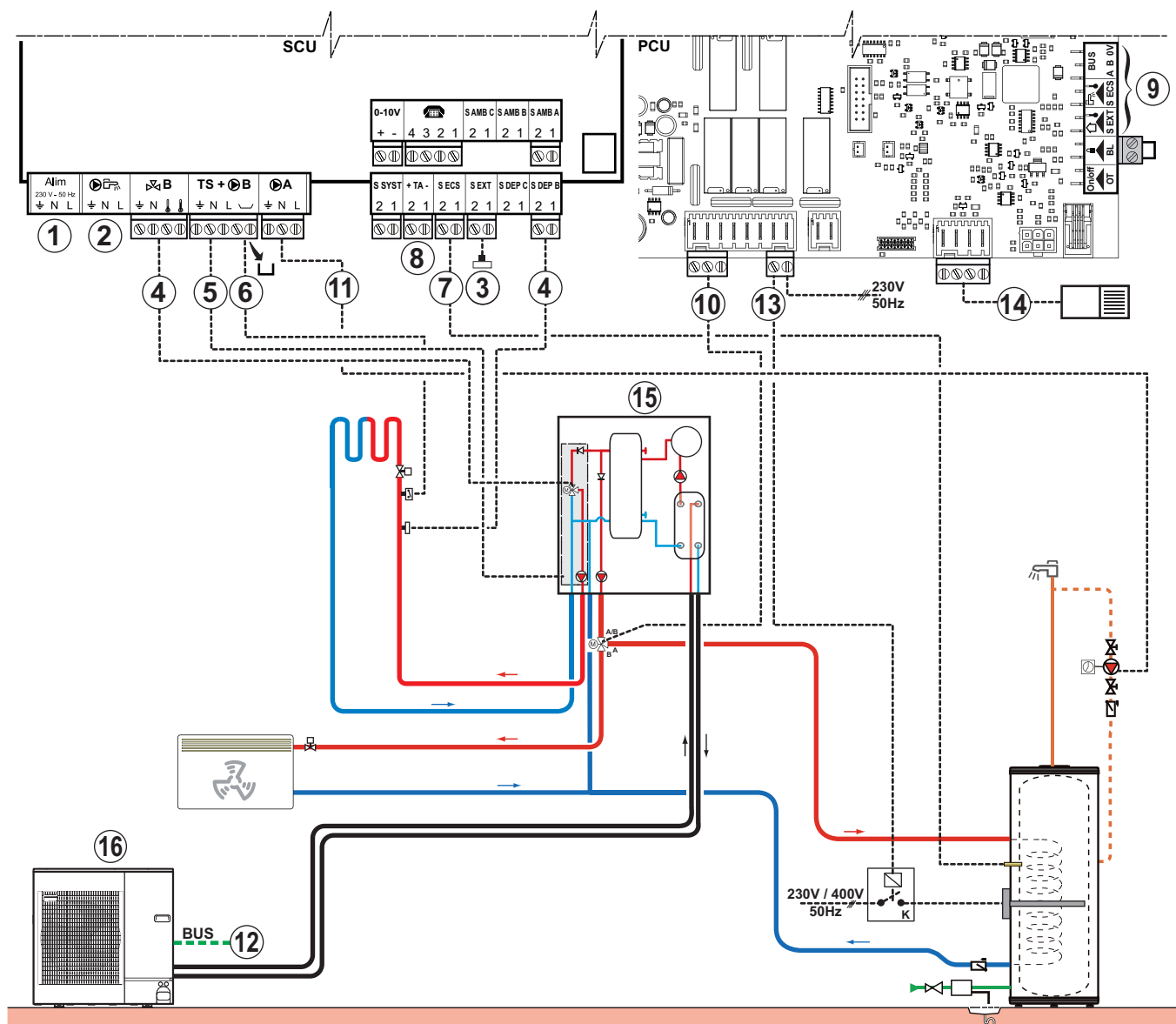

M003035-B

① Not used: Do not connect anything to the terminal block.

② **CAUTION**
 Do not connect anything to the DHW pump outlet as the reversal valve is connected to the PCU PCB in the boiler.

③ Connect the outside temperature sensor.

④ Connect the 3-way valve motor (circuit B) and the circuit B flow sensor.

⑤ Connect the heating pump (Circuit B).

⑥ Connect a safety thermostat if the heating circuit is for underfloor heating: Remove the bridge. Connect the wires from the safety thermostat to the connector.

⑦ Connect the DHW sensor.

⑧ Connect the DHW tank anode.

 **CAUTION**

- ▶ If the tank is fitted with a Titan Active System® impressed current anode, connect the anode to the inlet (+ TA on the anode, - on the tank).
- ▶ If the tank is not fitted with an impressed current anode, put the simulation connector in place (delivered with the DHW sensor - package AD212).

⑨ Not used: Do not connect anything to the terminal block.

⑩ Connect the motor on the DHW reversal valve.

⑪ Connect the domestic hot water looping pump to the  outlet.

⑫ Connect the BUS cable between the outside module and the terminal block on the inside module.

 "Connecting the communication cable between the inside and outside modules", page 47.

⑬ Connect the relay command on the tank heating resistor to the ELEC ECS terminal block.

⑭ Connect the condensation detector (Option).







 The condensation detector shuts down cooling if there is a risk of condensation.

 **CAUTION**

We strongly advise installing the cold mode insulation kit to prevent any risk of condensation in the inside module.

⑮ Inside module with electrical back-up

⑯ Outdoor unit

Settings to be made for this type of installation			
Parameters	Access	Settings to be made	See chapter
INSTALLATION	Installer level #SYSTEM menu	EXTENDED	 "Displaying the parameters in extended mode", page 84
O.PUMP A ⁽¹⁾	Installer level #SYSTEM menu	DHW LOOP	 "Setting the parameters specific to the installation", page 86
CIRC.A ⁽¹⁾	Installer level #SYSTEM menu	FAN CONVECTOR	 "Setting the parameters specific to the installation", page 86
PUMP MIT/MHR	Installer level #SYSTEM menu	CIRC.A	 "Setting the parameters specific to the installation", page 86
CIRC.B ⁽¹⁾	Installer level #SYSTEM menu	3WV	 "Setting the parameters specific to the installation", page 86
COOLING	Installer level #PRIMARY INSTAL.P menu	YES+DHW	 "Professional settings", page 98

(1) The parameter is only displayed if **INSTALLATION** parameter is set to **EXTENDED**

Settings to be made for this type of installation			
Parameters	Access	Settings to be made	See chapter
DHW BACKUP	Installer level #PRIMARY INSTAL.P menu	MIT/D.COOL	"Professional settings", page 98
DHW TYPE	Installer level #PRIMARY INSTAL.P menu	SECONDARY	"Professional settings", page 98
MINI COOLING A	Installer level #SECONDARY INSTAL.P menu	7 °C	"Professional settings", page 98
MINI COOLING B	Installer level #SECONDARY INSTAL.P menu	10 °C	"Professional settings", page 98

(1) The parameter is only displayed if **INSTALLATION** parameter is set to **EXTENDED**

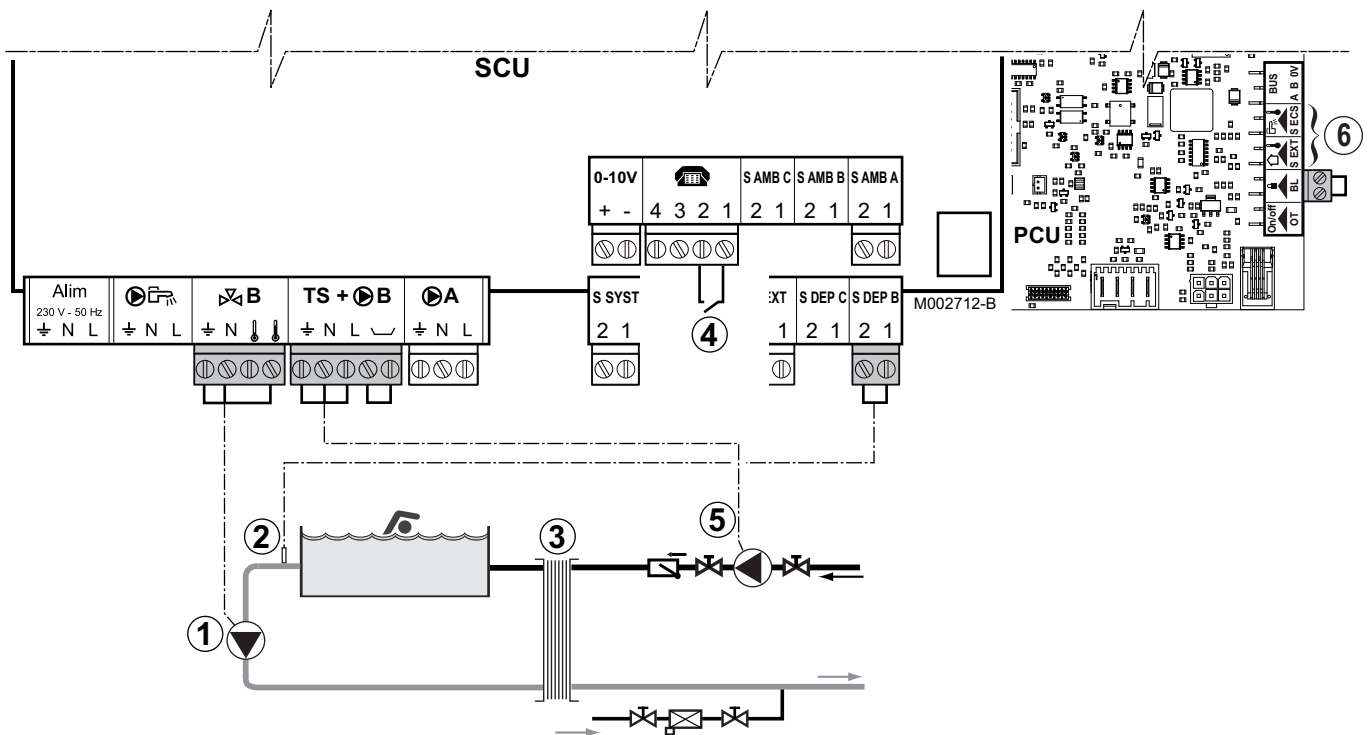

4.11.15. Pool connection



- ① Connect the secondary swimming pool pump.
- ② Connect the swimming pool sensor.
- ③ Plate heat exchanger.
- ④ Pool heating cut-off control

i When the parameter **I.TEL** is on **0/1 B**, the swimming pool is no longer heated when the contact is open (factory setting), only the antifreeze continues to be active. The contact direction can still be adjusted by the parameter **CT.TEL**.

- ⑤ Connect the primary swimming pool pump.
- ⑥ Do not connect anything to the terminal block.

Settings to be made for this type of installation			
Parameters	Access	Settings to be made	See
INSTALLATION	Installer level Menu # SYSTEM	EXTENDED	 "Displaying the parameters in extended mode", page 84
CIRC.B	Installer level Menu # SYSTEM	SWIM.P.	 "Setting the parameters specific to the installation", page 86
If I.TEL is used	Installer level Menu # SYSTEM	0/1 B	
MAX. CIRC. B	Installer level Menu # SECONDARY LIMITS	Set the value of MAX.CIRC.B to the temperature corresponding to the needs of the exchanger	 "Professional settings", page 98

■ Controlling the pool circuit

The control system can be used to manage a swimming pool circuit in both cases:

Case 1: The control system regulates the primary circuit (boiler/exchanger) and the secondary circuit (exchanger/pool).

- ▶ Connect the primary circuit pump (boiler/exchanger) to the **►B** outlet on the connection terminal block. The temperature **MAX. CIRC. B** is then guaranteed during comfort periods on programme **B** in summer and winter alike.
- ▶ Connect the swimming pool sensor (package AD212) to the **S DEP B** inlet on the connection terminal block.
- ▶ Set the set point of the pool sensor using key **↓** in the range 5 - 39°C.

Case 2: The pool has already a regulation system that is to be kept. The control system only regulates the primary circuit (boiler/exchanger).

- ▶ Connect the primary circuit pump (boiler/exchanger) to the **►B** outlet on the connection terminal block.
The temperature **MAX. CIRC. B** is then guaranteed during comfort periods on programme **B** in summer and winter alike.



The swimming pool must also be connected to circuit **C** by adding the additional 3-way valve option. With optional package AD249:

- ▶ Make the connection to the terminal blocks marked **C**.
- ▶ Set the parameters for circuit **C**.

■ Hourly programming of the secondary circuit pump

The secondary pump operates during programme **B** comfort periods in summer and winter alike.

■ Stopping

To prepare your pool for winter, consult your pool specialist.

4.11.16. Connecting the options

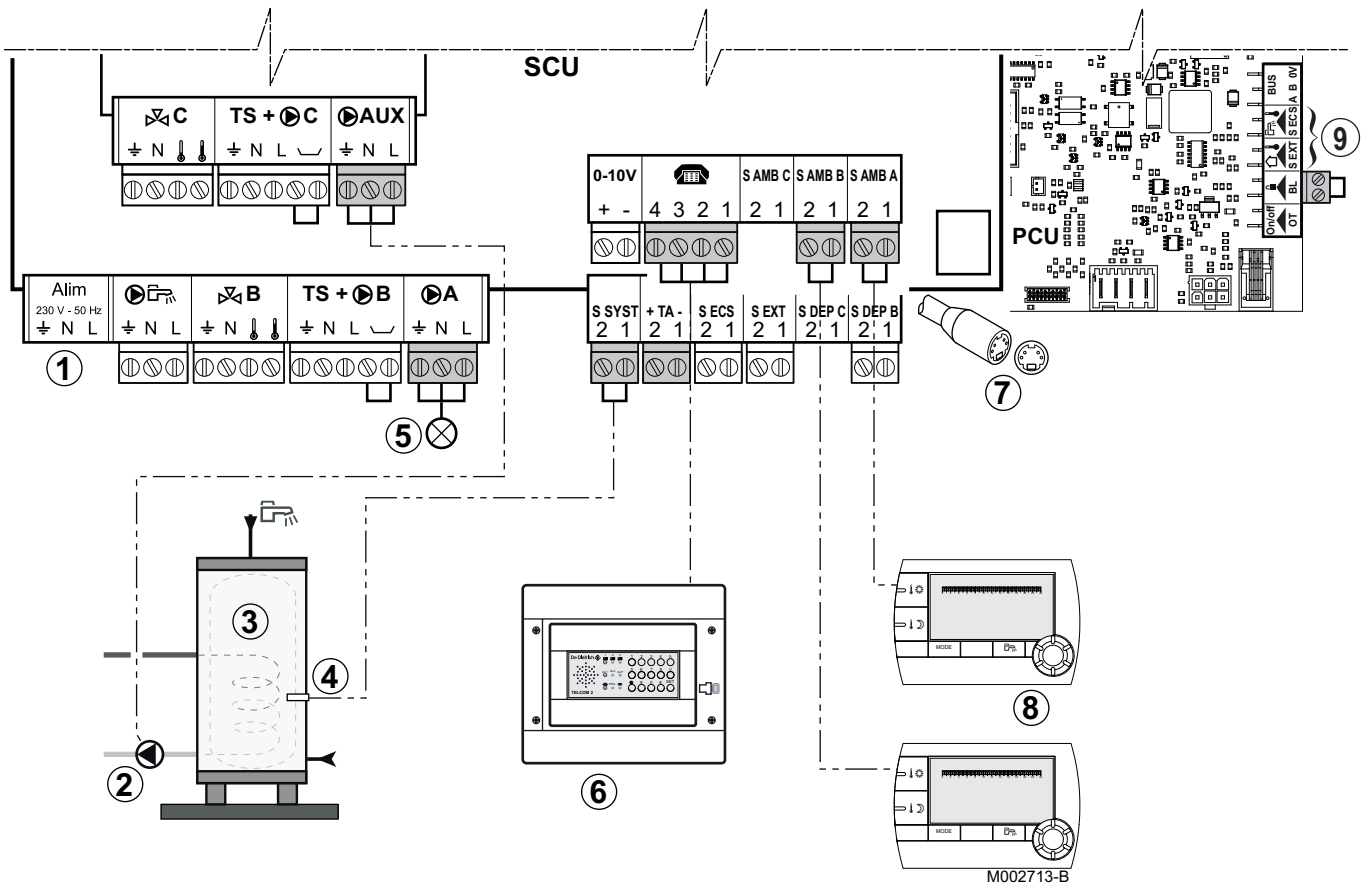

- ① Do not connect anything to the terminal block.
- ② Connect the load pump of the second tank.
- ③ Second domestic hot water tank
- ④ Connect the DHW sensor of the second tank.
- ⑤ Alarm indicator
- ⑥ Connect the TELCOM remote vocal monitoring module (depending on its availability in your country).
- ⑦ Connecting the BUS cascade, VM
- ⑧ Connect the remote control (Package AD254/FM52).
- ⑨ Do not connect anything to the terminal block.

Settings to be made for this type of installation			
Parameters	Access	Settings to be made	See chapter
INSTALLATION	Installer level #SYSTEM menu	EXTENDED	"Displaying the parameters in extended mode", page 84
O.PUMP A⁽¹⁾	Installer level #SYSTEM menu	FAILURE	"Setting the parameters specific to the installation", page 86
If second tank connected: S.AUX⁽¹⁾	Installer level #SYSTEM menu	DHW	

(1) The parameter is only displayed if **INSTALLATION** parameter is set to **EXTENDED**

4.11.17. Connecting the "energy metering" option

■ Operating principle

The "energy metering" option provides data on electrical energy consumption and thermal energy production by the outside module, the inside module and the back-ups, according to the chosen configuration (heating, DHW, etc.). The restored values are memorised for two years and can be viewed on the control panel display.

■ Specifications of the energy meters

Electrical energy meter:

- ▶ Opto-insulated pulse output.
- ▶ Minimum admissible voltage: 27 V
- ▶ Minimum admissible intensity: 20 mA
- ▶ Minimum pulse time: 25 ms
- ▶ Maximum frequency: 20 Hz
- ▶ Pulse weight: Between 1 and 1000 Wh.

Thermal energy meter (Optional):

- ▶ Opto-insulated pulse output.
- ▶ Minimum admissible voltage: 27 V
- ▶ Minimum admissible intensity: 3 mA
- ▶ Minimum pulse time: 5 ms
- ▶ Maximum frequency: 100 Hz
- ▶ Pulse weight: Between 10 and 1000 Wh.

If the thermal energy meter is connected, the pulses are added at the thermal energy value calculated by the sensors and the flowmeter.

■ Adjustment

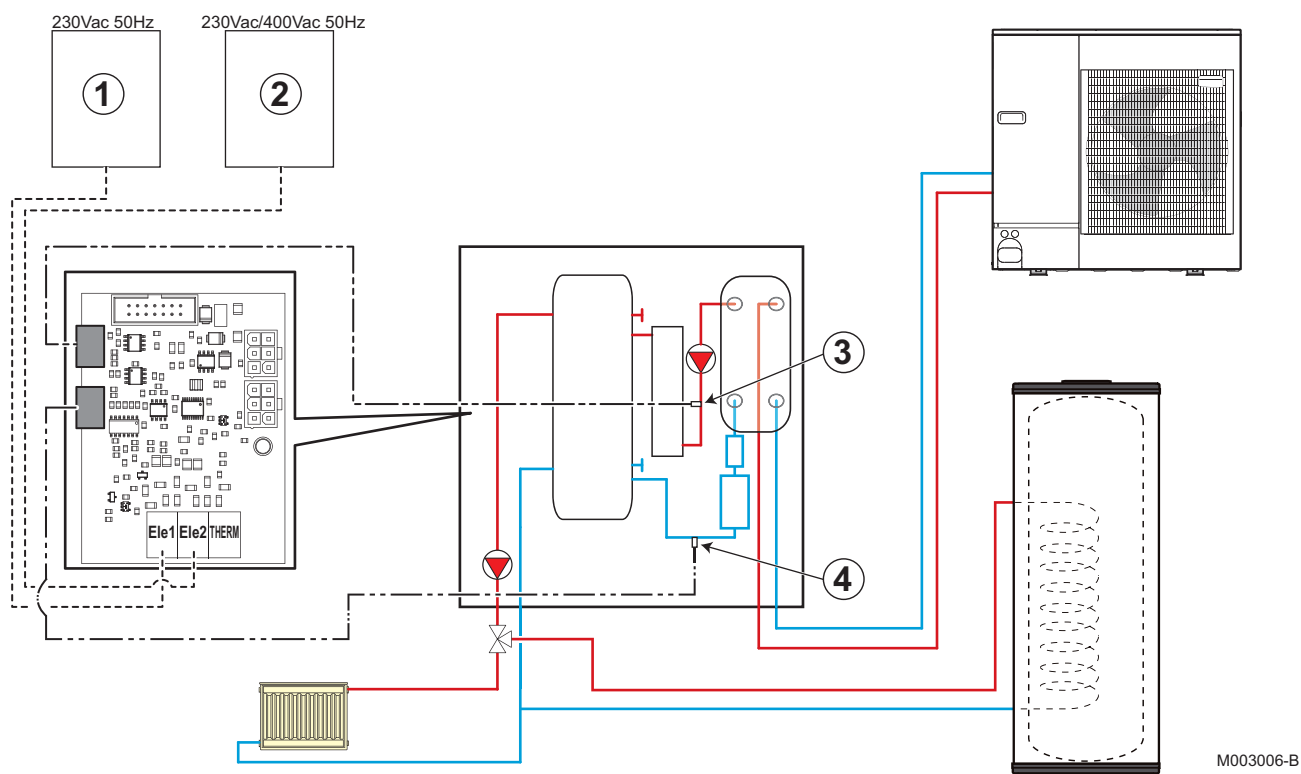

- ① Electricity meter (to meter the electrical energy consumed by the outside module).
- ② Electricity meter (to meter the electrical energy consumed by the inside module (without electric back-ups)).
- ③ Output sensor - PT100.
- ④ Return sensor - PT100.



The second electricity meter is not compulsory but can be used to tally the energy absorbed by the inside module (PCBs, circulating pumps, 3-way valves, etc.). The thermal energy is calculated thanks to the two sensors connected to the PCB and the flowmeter in the inside module.

Refer to the instructions delivered with the option (HK29).

**CAUTION**

Do not install meters for the electric back-ups. The power input when setting the parameters is used to automatically calculate the consumed and restored energy.

Settings to be made for this type of installation			
Parameters	Access	Settings to be made	See chapter
INSTALLATION	Installer level #SYSTEM menu	EXTENDED	"Displaying the parameters in extended mode", page 84
FLOWM.LOC. ⁽¹⁾	Installer level Menu #ENERGY COUNTERS	PCU 194	"Professional settings", page 98
GLYCOL ⁽¹⁾	Installer level Menu #ENERGY COUNTERS	0%	
ELEC.PUL.VAL.1 ⁽¹⁾	Installer level Menu #ENERGY COUNTERS	According to the specifications of the electricity meter	
ELEC.PUL.VAL.2 ⁽¹⁾	Installer level Menu #ENERGY COUNTERS	According to the specifications of the electricity meter	
BACKUP 1 ⁽¹⁾	Installer level Menu #ENERGY COUNTERS	According to the stage 1 output configuraton on the electrical back-ups "Connecting the electrical back-up to the inside module", page 49	
BACKUP 2 ⁽¹⁾	Installer level Menu #ENERGY COUNTERS	According to the stage 2 output configuraton on the electrical back-ups "Connecting the electrical back-up to the inside module", page 49	
DHW RESISTOR ⁽¹⁾	Installer level Menu #ENERGY COUNTERS	According to the electrical resistor output of the DHW tank	

(1) The parameter is only displayed if **INSTALLATION** parameter is set to **EXTENDED**

Examples of settings:

Metering the energy of the heat pump only: Set parameters **BACKUP 1** and **BACKUP 2** to 0. Set parameter **DHW RESISTOR** to 0.

Metering the energy of the heat pump and the back-ups: Set parameters **BACKUP 1** and **BACKUP 2** according to the output configuration of the stages of the electrical back-ups ("Connecting the electrical back-up to the inside module", page 49).

Set parameter **DHW RESISTOR** according to the electrical output of the DHW tank.

4.11.18. Connection in cascade

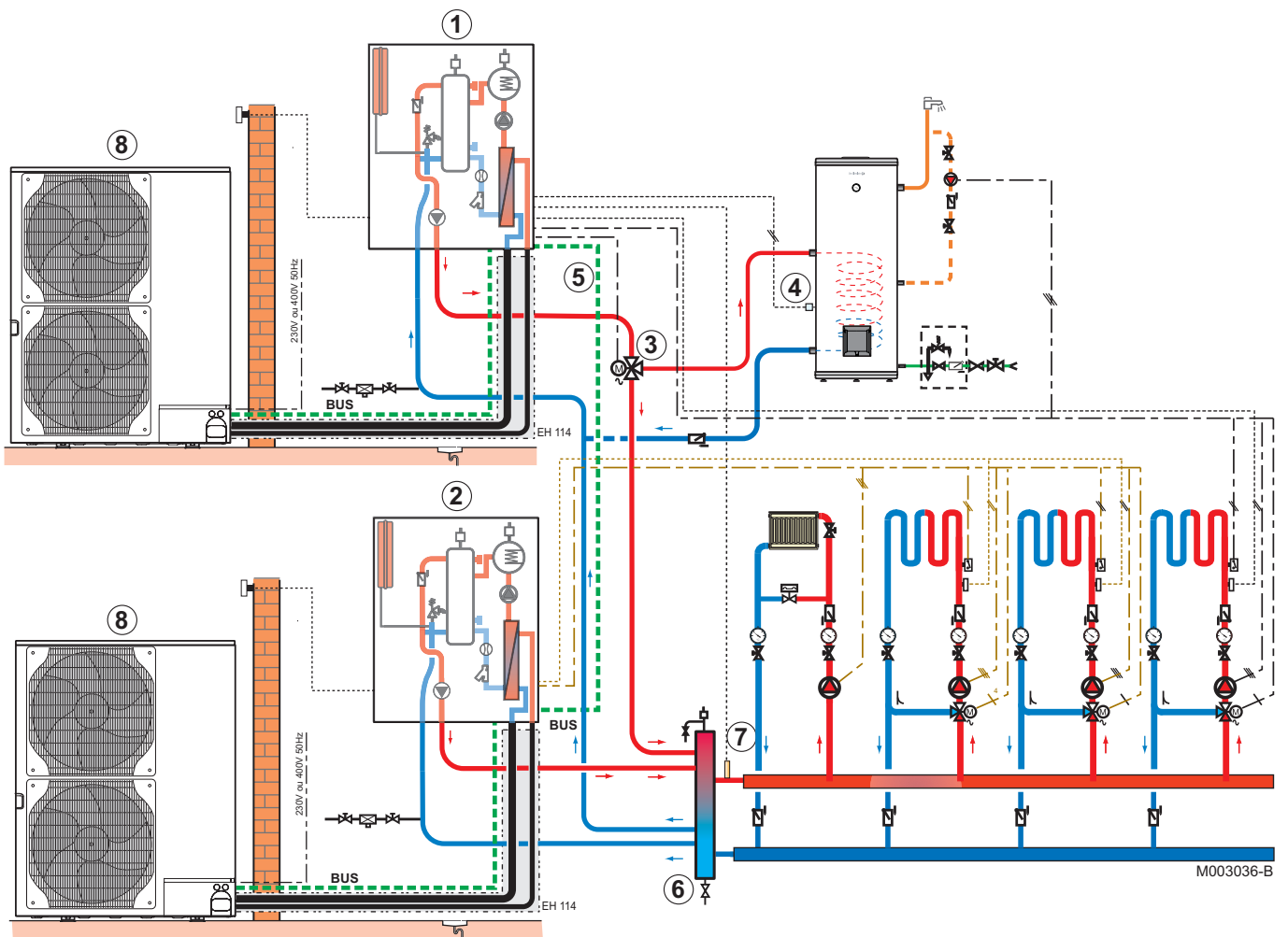

- ① Master inside module
- ② Slave inside module
- ③ Reversal valve (Package HK23)
- ④ Connect the DHW sensor (Package AD212)
- ⑤ BUS cable
- ⑥ Low loss header
- ⑦ Cascade outlet sensor
Connect the sensor to the S SYST terminal block on the master appliance.
- ⑧ Outdoor unit

**CAUTION**

The "cooling" function is impossible with a connection in cascade.

Settings to be made for this type of installation: master module			
Parameters	Access	Settings to be made	See chapter
INSTALLATION	Installer level Menu #SYSTEM	EXTENDED	"Displaying the parameters in extended mode", page 84
CASCADE ⁽¹⁾	Installer level Menu #NETWORK	ON	"Configuring the network", page 109
MASTER CONTROLER ⁽¹⁾	Installer level Menu #NETWORK	ON	
SYSTEM NETWORK ⁽¹⁾	Installer level Menu #NETWORK	Enlist generators or VMs in cascade mode.	
(1) The parameter is only displayed if INSTALLATION parameter is set to EXTENDED			

Settings to be made for this type of installation: slave module			
Parameters	Access	Settings to be made	See chapter
INSTALLATION	Installer level Menu #SYSTEM	EXTENDED	"Displaying the parameters in extended mode", page 84
CASCADE ⁽¹⁾	Installer level Menu #NETWORK	ON	"Configuring the network", page 109
MASTER CONTROLER ⁽¹⁾	Installer level Menu #NETWORK	OFF	
SLAVE NUMBER ⁽¹⁾	Installer level Menu #NETWORK	2, 3, ...	
(1) The parameter is only displayed if INSTALLATION parameter is set to EXTENDED			

4.11.19. Connection example in power cut off EVU

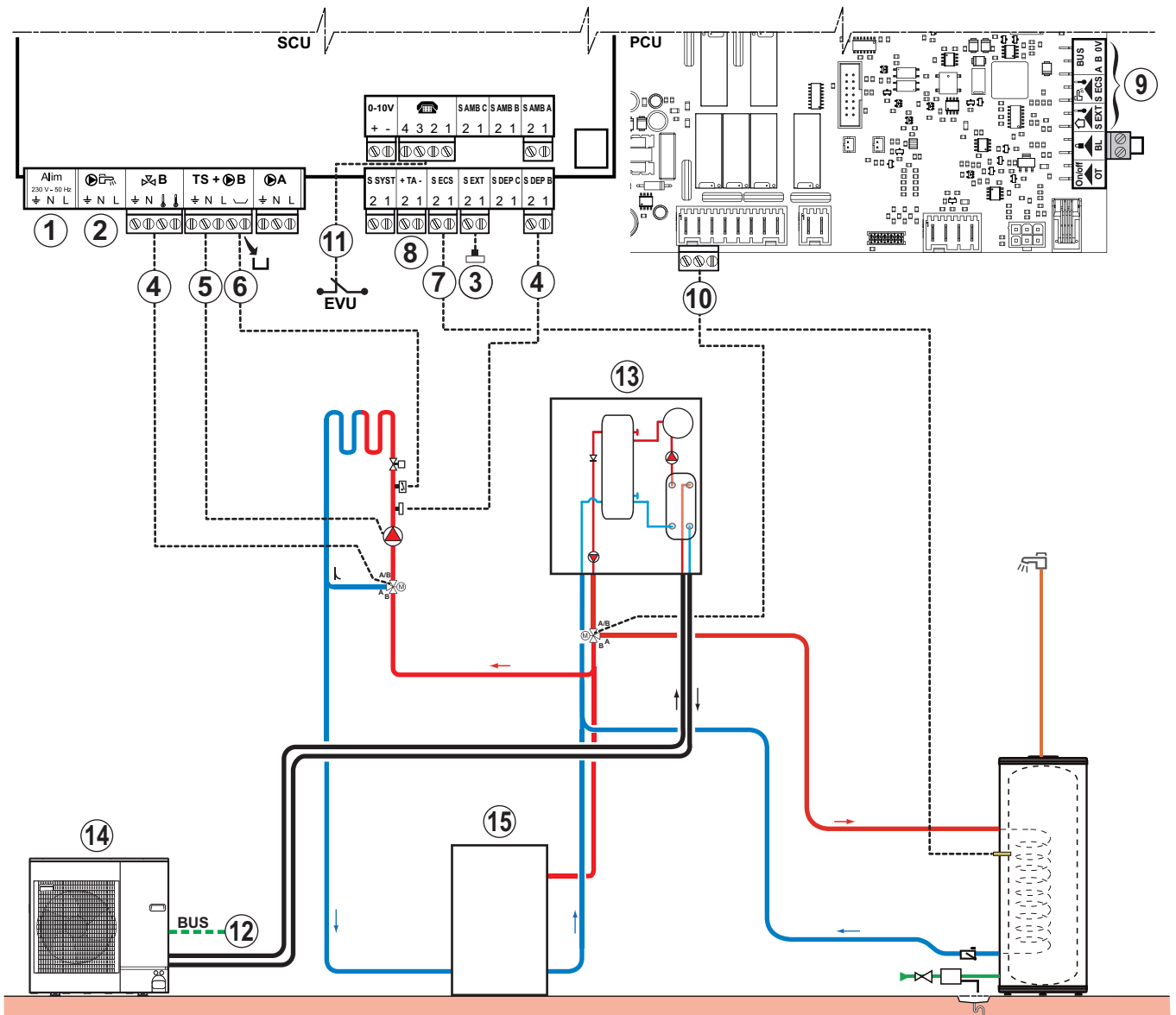

M003037-B











- ① Not used: Do not connect anything to the terminal block.
- ② **CAUTION**
Do not connect anything to the DHW pump outlet as the reversal valve is connected to the PCU PCB in the boiler.
- ③ Connect the outside temperature sensor.
- ④ Connect the 3-way valve motor (circuit B) and the circuit B flow sensor.
- ⑤ Connect the heating pump (Circuit B).
- ⑥ Connect a safety thermostat if the heating circuit is for underfloor heating: Remove the bridge. Connect the wires from the safety thermostat to the connector.
- ⑦ Connect the DHW sensor (Package AD212).

- ⑧ Connect the DHW tank anode.



**CAUTION**

- ▶ If the tank is fitted with a Titan Active System® impressed current anode, connect the anode to the inlet (+ TA on the anode, - on the tank).
- ▶ If the tank is not fitted with an impressed current anode, put the simulation connector in place (delivered with the DHW sensor - package AD212).

- ⑨ Not used: Do not connect anything to the terminal block.
- ⑩ Connect the motor on the DHW reversal valve.
- ⑪ Connect the EVU contact to the 1-2 terminals on the TEL connector.
- ⑫ Connect the BUS cable between the outside module and the terminal block on the inside module.
 "Connecting the communication cable between the inside and outside modules", page 47.
- ⑬ Inside module with electrical back-up
- ⑭ Outdoor unit
- ⑮ Buffer tank

Settings to be made for this type of installation			
Parameters	Access	Settings to be made	See chapter
INSTALLATION	Installer level #SYSTEM menu	EXTENDED	 "Displaying the parameters in extended mode", page 84
CIRC.A ⁽¹⁾	Installer level #SYSTEM menu	DIRECT	 "Setting the parameters specific to the installation", page 86
PUMP MIT/MHR	Installer level #SYSTEM menu	CIRC.A	 "Setting the parameters specific to the installation", page 86
CIRC.B ⁽¹⁾	Installer level #SYSTEM menu	3WV	 "Setting the parameters specific to the installation", page 86
CT.TEL	Installer level #SYSTEM menu	CLOSE	 "Setting the parameters specific to the installation", page 86
I.TEL	Installer level #SYSTEM menu	0/1 EVU	 "Setting the parameters specific to the installation", page 86
DHW TYPE	Installer level #PRIMARY INSTAL.P menu	SECONDARY	 "Professional settings", page 98
BACKUP TYPE	Installer level #PRIMARY INSTAL.P menu	/E1: Stage 1 /E2: Stage 2	 "Professional settings", page 98
HP BUS	Installer level #PRIMARY INSTAL.P menu	TOR	 "Professional settings", page 98
CIRC.CURVE A	Installer level #SECONDARY INSTAL.P menu	0.7	 "Professional settings", page 98

(1) The parameter is only displayed if **INSTALLATION** parameter is set to **EXTENDED**

Settings to be made for this type of installation			
Parameters	Access	Settings to be made	See chapter
CIRC.CURVE B	Installer level #SECONDARY INSTAL.P menu	0.7	 "Professional settings", page 98
OFFSET EVU	Installer level #SECONDARY INSTAL.P menu	7 °C	 "Professional settings", page 98
EVU TIMER PROG.	User level Menu #TIME PROGRAM	Set the timer programme according to the power cut off hours EVU .	 Refer to the user instructions.

(1) The parameter is only displayed if **INSTALLATION** parameter is set to **EXTENDED**

4.12 Electrical principle diagram

4.12.1. Legend

0-10 V	Input
ⓐ, ⓑ	Baffle, Circuit A, B
AL1 ⓐ, AL2	Hydraulic additional heating
C1, C2, C3	Homologation
CN21	Cooling sensor
CN20	Heating sensor
CN2A	HP setpoint
CNX2	Machine fault
CNX4	Defrosting
CNX3	Compressor - ON
ECS	Electrical back-up - Domestic hot water
F6.3AT	6.3A fuse
HMI	Display
J-	PCB connector
L	Live
L1, L2, L3, D3, N	Auxiliary electrical power supply
N	Neutral
PCU	Primary control unit
Res	Resistance
RL.	Relay
S2, S3	bus
SONDE ECS	Domestic hot water sensor

SONDE SYST	System sensor
SONDE AMB A, B, C	Room sensor A, B, C
SONDE DEP B, C	Outlet sensor B, C
SONDE EXT	Outside sensor
TA	Titan Active System
TB6, TB142	Terminal block interface board
TS	Safety thermostat
V3V	3-way valve
X-	PCB connector - PCU
X25	HP pump
X28	Outlet sensor
X29	Flowmeter
X30	Pressure gauge
XA	Through-feed terminal unit
SCU	DIEMATIC iSystem control panel PCB
ZG	General switch
✕	DHW circuit reversal valve

4.12.2. Hydraulic additional heating

PRINCIPLE DIAGRAM INVERTER HYDRAULIC

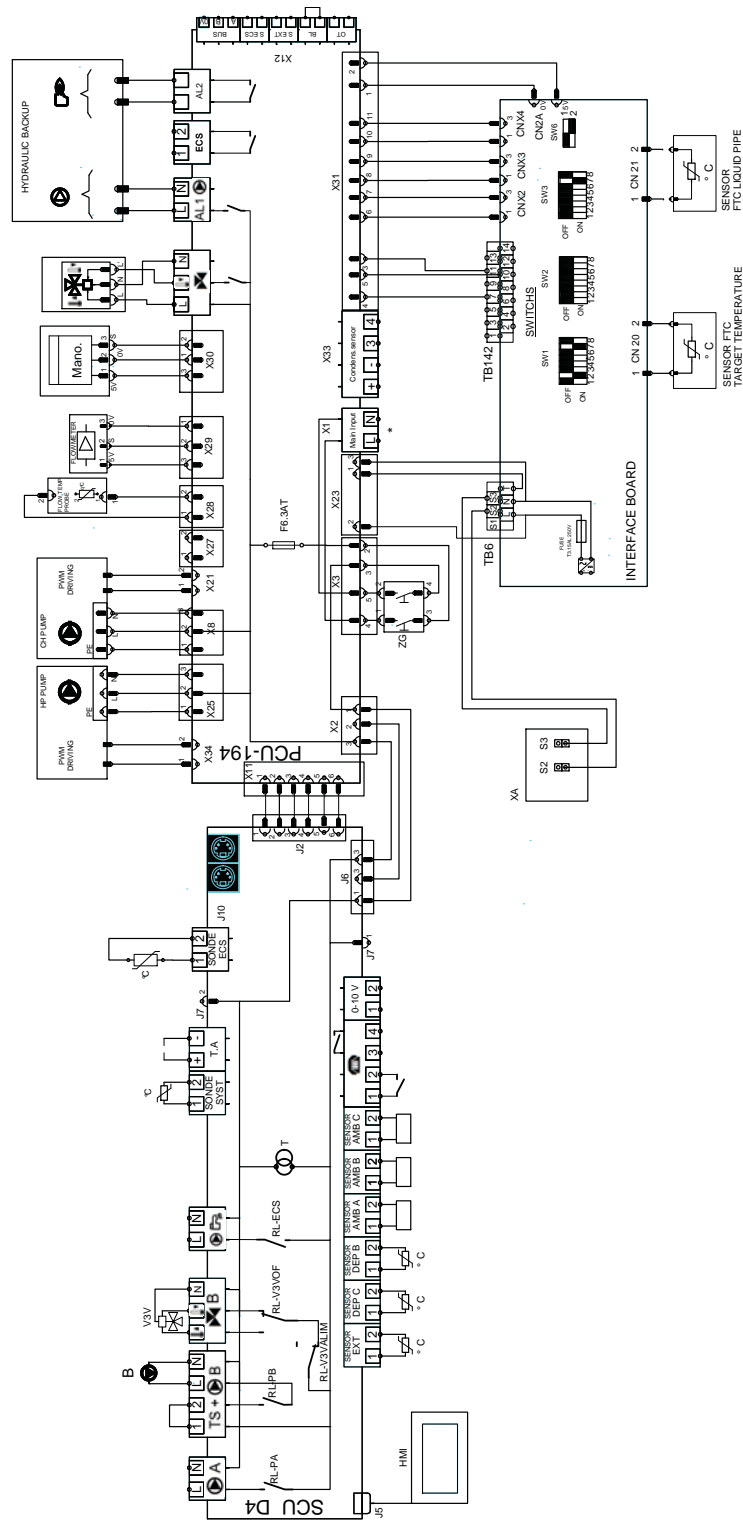

* : 230V AC Main power supply

4.12.3. Electrical back-up

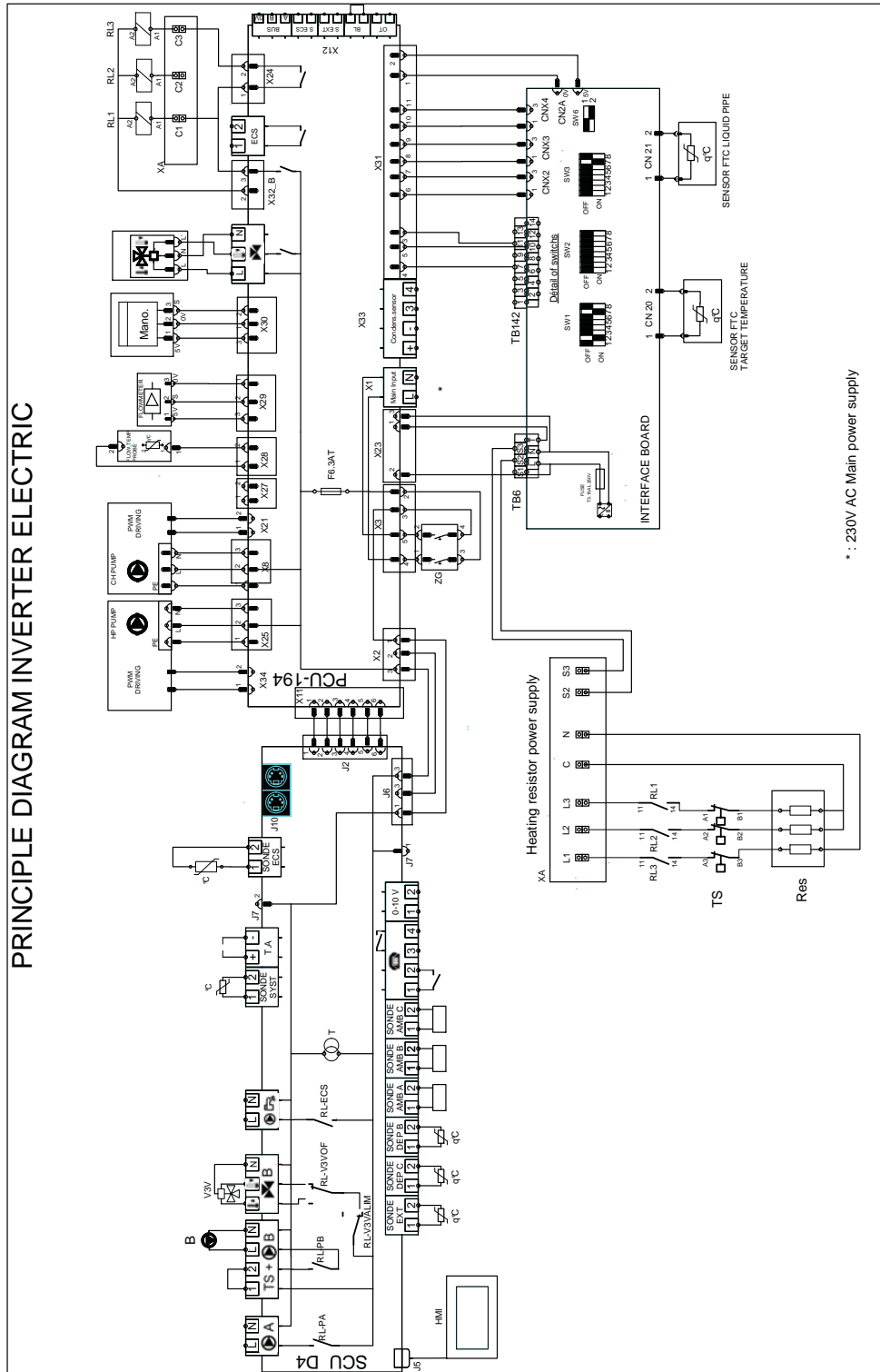

5 Commissioning

5.1 Control panel

5.1.1. Description of the keys

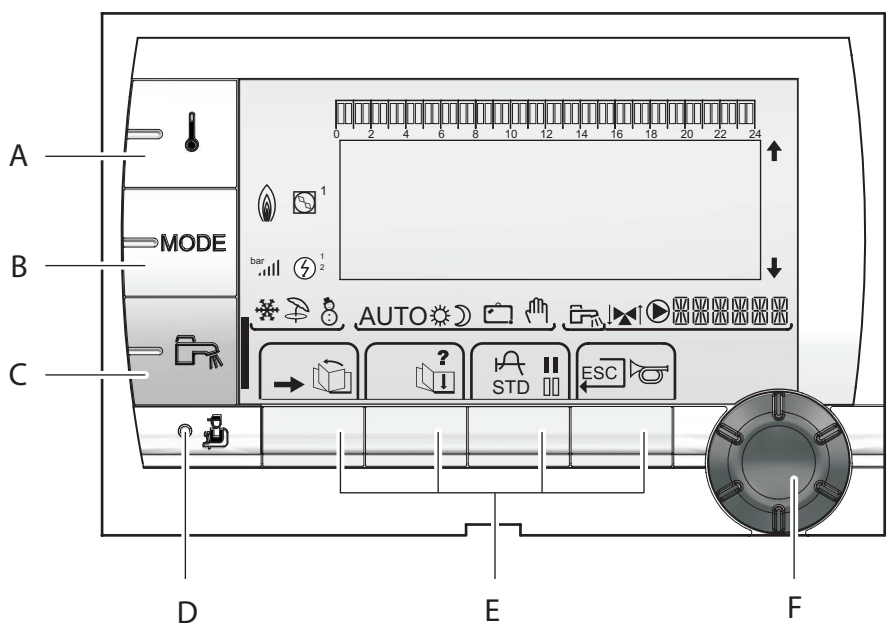

- A** Temperature setting key (heating, DHW, swimming pool)
- B** Operating mode selection key
- C** DHW override key
- D** Key to access the parameters reserved for the installer
- E** Keys on which the function varies as and when selections are made
 See: "Key functions", page 76
- F** Rotary setting button:
 - ▶ Turn the rotary button to scroll through the menus or modify a value
 - ▶ Press the rotary button to access the selected menu or confirm a value modification

5.1.2. Description of the display

■ Key functions

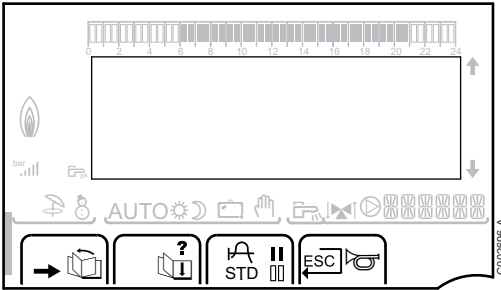

- Access to the various menus
- Used to scroll through the menus
- Used to scroll through the parameters
- ? The symbol is displayed when help is available
- Used to display the curve of the parameter selected
- STD** Reset of the time programmes
- Selection of comfort mode or selection of the days to be programmed
- Selection of reduced mode or deselection of the days to be programmed
- Back to the previous level
- ESC** Back to the previous level without saving the modifications made
- Manual reset

■ Solar (If connected)

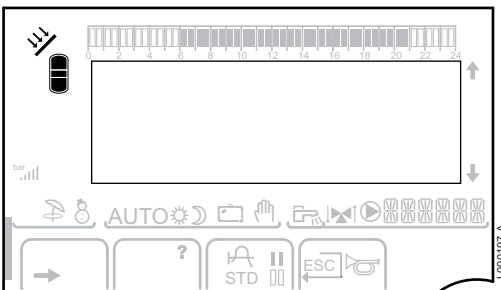



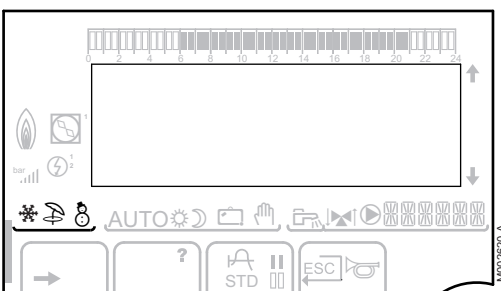

- The solar load pump is running
- The top part of the tank is reheated to the tank set point
- The entire tank is reheated to the tank set point
- The entire tank is reheated to the solar tank set point
- The tank is not loaded - Presence of the solar control system

■ Operating modes

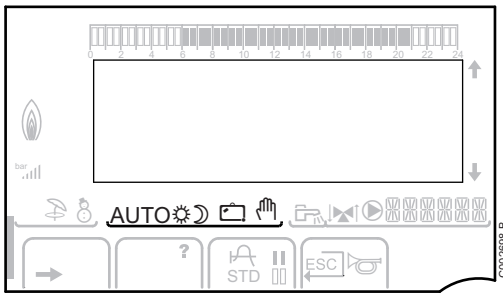



- Summer mode: Cooling is possible. Domestic hot water continues to be produced.
- WINTER mode: Heating and domestic hot water working.
- Forced cooling mode.
- Cooling mode: Heating according to the time programme.

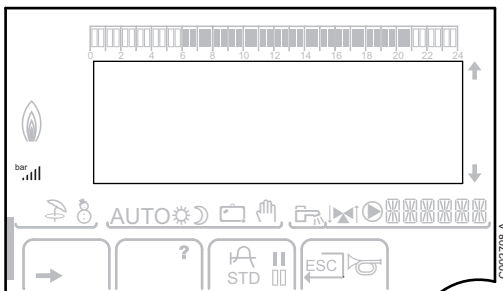

- AUTO** Operation in automatic mode according to the timer programme.
-  Comfort mode: The symbol is displayed when a DAY override (comfort) is activated.
 - ▶ Flashing symbol: Temporary override
 - ▶ Steady symbol: Permanent override
-  Reduced mode: The symbol is displayed when a NIGHT override (reduced) is activated.
 - ▶ Flashing symbol: Temporary override
 - ▶ Steady symbol: Permanent override
-  Holiday mode: The symbol is displayed when a HOLIDAY override (antifreeze) is activated.
 - ▶ Flashing symbol: Holiday mode programmed
 - ▶ Steady symbol: Holiday mode active
-  Manual mode

■ System pressure



- bar** Pressure indicator: The symbol is displayed when a water pressure sensor is connected.
 - ▶ Flashing symbol: The water pressure is insufficient.
 - ▶ Steady symbol: The water pressure is sufficient.
-  Water pressure level
 - ▶ .: 0,9 to 1,1 bar
 - ▶ .: 1,2 to 1,5 bar
 - ▶ .: 1,6 to 1,9 bar
 - ▶ .: 2,0 to 2,3 bar
 - ▶ .: > 2,4 bar

■ Domestic Hot Water override

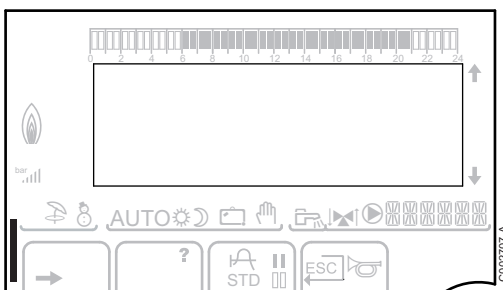

- A bar is displayed when a DHW override is activated:
- ▶ Flashing bar: Temporary override
 - ▶ Steady bar: Permanent override

■ Electrical back-up

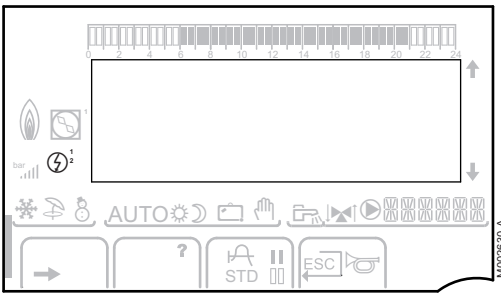

- ⚡ The symbol **1** or **2** lights up, depending on whether stage 1 or 2 on the electrical back-up is commanded.

■ Hydraulic additional heating

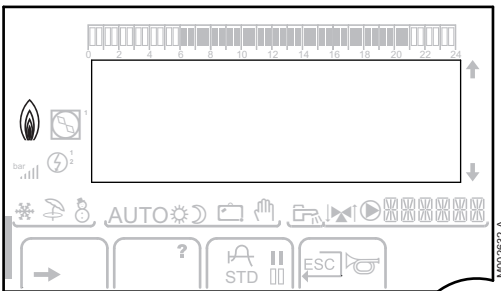

- 🔥
 - ▶ Steady symbol: The burner and the heating pump on the back-up boiler are commanded.
 - ▶ Flashing symbol: The heating pump on the back-up boiler is commanded.

■ Status of the compressor

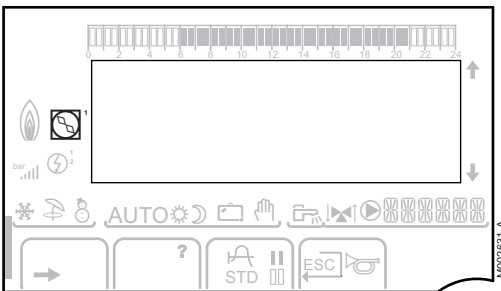

- 🔧
 - ▶ Steady symbol: The compressor is running.
 - ▶ Flashing symbol: The heat pump is required but the compressor is off.

■ Other information

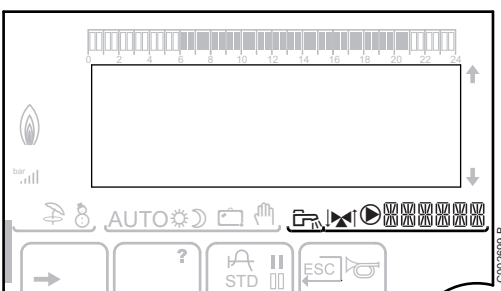

- 🔧 The symbol is displayed when domestic hot water production is running.
- ⚡ Valve indicator: The symbol is displayed when a 3-way valve is connected.
 - ▶ 🔧: 3-way valve opens
 - ▶ 🔧: 3-way valve closes
- 🔧 The symbol is displayed when the pump is operating.
- 🔧 Name of the circuit for which the parameters are displayed.

5.1.3. Access to the various browsing levels

■ User level

The information and settings in the User level can be accessed by everyone.

1. Press the → key.

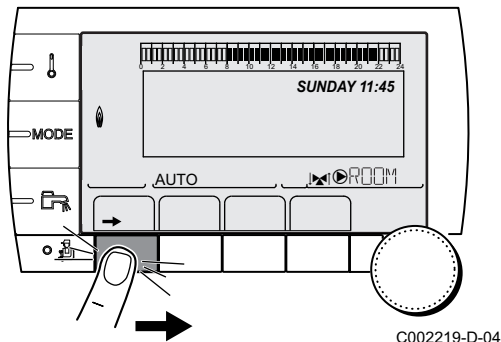

■ Installer level

The information and settings in the Installer level can be accessed by experienced people.

1. Press the → key.

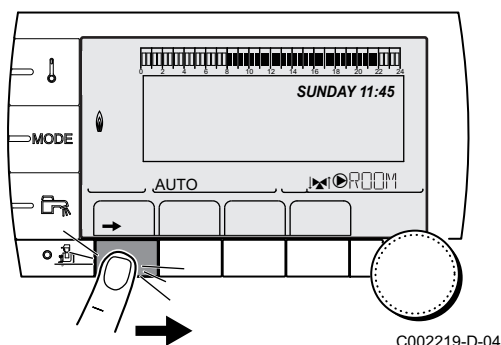

2. Press the  key.



It is also possible to access the installer level by pressing only the  key for around 5 seconds.

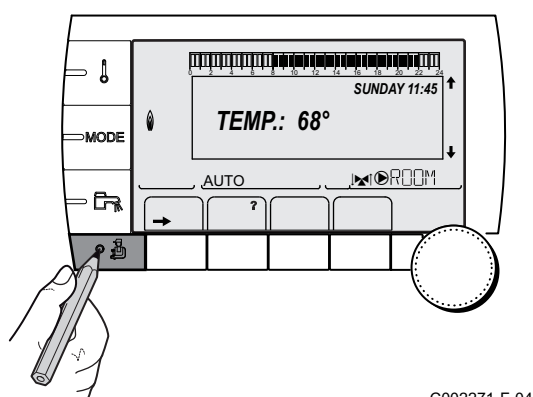

■ After Sales level

The After Sales Service information and settings can be accessed by the professional providing the After Sales Service.

1. Press the → key.

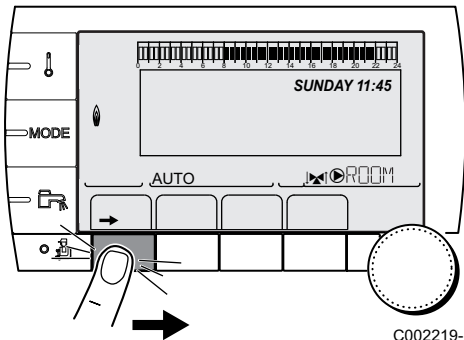

C002219-D-04

2. Press key  for around 5 seconds.

i It is also possible to access the After Sales level by pressing only the  key for around 10 seconds.

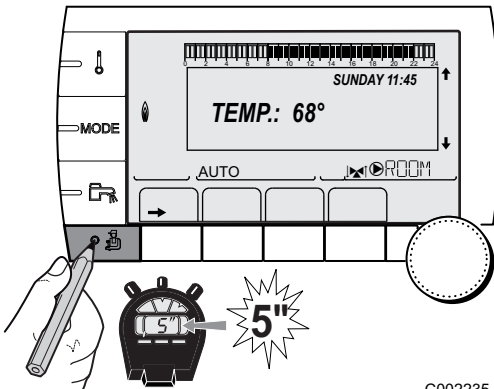

C002235-F-04

5.1.4. Browsing in the menus

1. To select the desired menu, turn the rotary button.
2. To access the menu, press the rotary button.
To go back to the previous display, press the key .

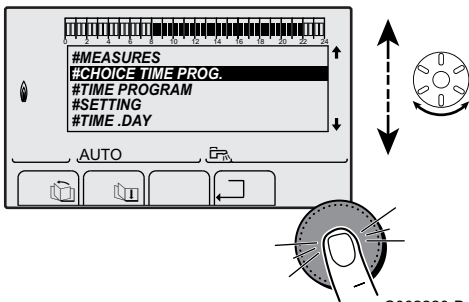

C002220-B-04

3. To select the desired parameter, turn the rotary button.
4. To modify the parameter, press the rotary button.
To go back to the previous display, press the key .

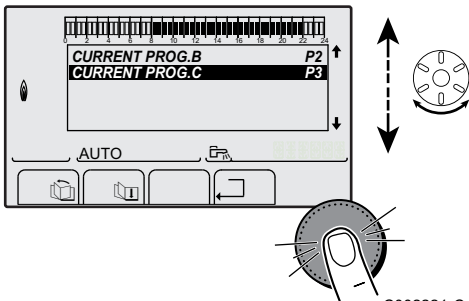

C002221-C-04

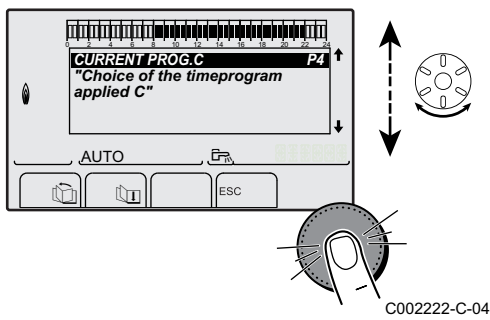

5. To modify the parameter, turn the rotary button.
6. To confirm, press the rotary button.



To cancel, press key ESC.

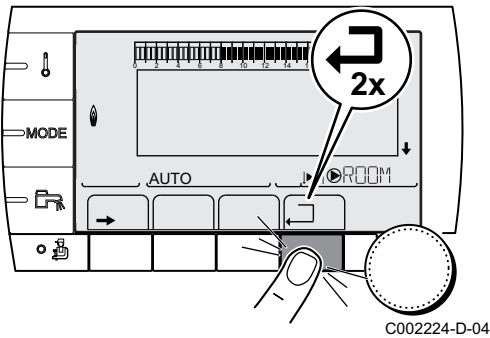

7. To go back to the main display, press key \square 2 times.



It is possible to use the  and  keys instead of the rotary button.

5.2 Check points before commissioning

5.2.1. Hydraulic connections

- ▶ Hoses correctly connected to the heat pump.
- ▶ Fill the installation with water and check hydraulic tightness.
- ▶ Vent the installation with the on/off cycles. Be sure to open all valves on the heating circuit and the thermostatic valves on the radiators.
- ▶ After venting, check that the filters are not clogged. Clean the filters.
- ▶ Raise the pressure to 1.5 / 2 bar.

5.2.2. Electrical connection

Check the electrical connections, particularly the earth:

- ▶ HP: Mains supply connected
- ▶ Indoor module: Mains supply connected.
- ▶ depending on the version: Connecting the electrical back-up.
- ▶ HP modules interconnected by BUS cable.

5.3 Checklist for commissioning (HP)

▶ Range: ▶ Models: ▶ Soft version:			
Checklist before commissioning:		OK	OK
Position of the outside unit, distance from the wall			Other functions
Circulation direction of the hydraulic fluids			Cooling
Tightness of the refrigerant fittings			Mixing valve
Pressure during vacuum tapping before filling			
Electric		OK	Checks after start-up
Circuit breaker presence (curve C) recommended			After 1 hour's running
Tighten the terminals			Verification of tightness
Separation of the power and low voltage cables			Vent any air in the heating circuit using the appliance's air vent
EAC power cut off (blockage by the electricity supplier)? <input type="checkbox"/> ON <input type="checkbox"/> OFF			Check the water pressure
Mounting and position of the outside temperature sensor			Start-up of the heating circulating pumps
Mounting and position of the room sensor			No error on regulator
Presence and connection of the underfloor heating thermostat			Compressor starts
Heating mode checks		OK	Heat transfer to the heating circuits
Flow rate in the primary circuit			Additional heating function
ΔT heating (between 5 and 15°C)			Cleanliness of the filter
Setting the primary pump speed			Instruct the user on how the product operates
Setting the secondary pump speed			
Setting the temperature: 55 or 60°C			Notes:
Setting the minimum flow rate			
Remarks:			

5.4 Putting the appliance into operation

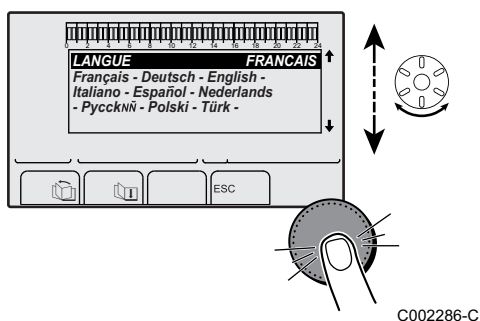
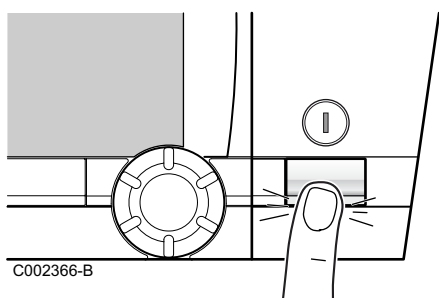
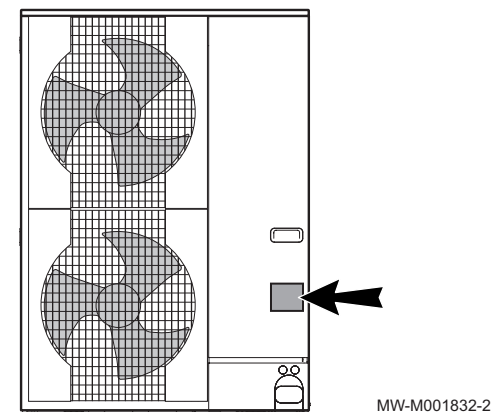

1. Make a note of the output and type shown on the outside module's nameplate.
2. Switch on the power by throwing the on/off switch on the inside module.
3. The first time the boiler is powered up, the **LANGUAGE** menu is displayed. Select the desired language by turning the rotary button.
4. To confirm, press the rotary button.
5. The parameter **TYPE** displays. According to the values noted on the outside module's nameplate, select the type of thermodynamic unit by turning the rotary button.

Outside module output	Indoor module	TYPE
From 4 to 16 kW	MIT-IN-2/E	MIT AWHP E HT FR
	MIT-IN-2/H	MIT AWHP H HT FR
22 and 27 kW	MIT-IN-2/E	MIT AWHP E FR
	MIT-IN-2/H	MIT AWHP H FR

Error during the start-up procedure:



- ▶ No information is shown on the display:
 - Check the mains supply voltage.
 - Check the fuse (👉 See chapter: "Location of the fuse", page 47).
 - Check the connection of the power cable to the connector on the PCU PCB (See chapter: 👉 "Connecting the mains supply to the inside module", page 49).
- ▶ If there is a problem, the error is displayed on the screen.
 - 👉 See chapter: "Messages", page 118.

5.5 Checks and adjustments after commissioning

5.5.1. Displaying the parameters in extended mode

The display mode on the control panel is set as standard in such a way as only to show the conventional parameters. It is possible to switch to extended mode by proceeding as follows:

1. Access the installer level: Press key  for around 5 seconds.
2. Select the menu **#SYSTEM**.

-  Turn the rotary button to scroll through the menus or modify a value.
-  Press the rotary button to access the selected menu or confirm a value modification.

 For a detailed explanation of menu browsing, refer to the chapter: "Browsing in the menus", page 80

3. Set parameter **INSTALLATION** to **EXTENDED**.

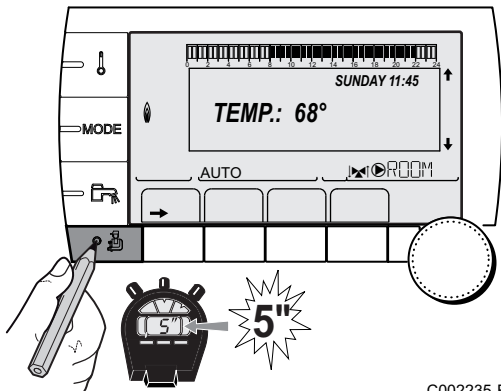

C002235-F-04



Installer level - Menu #SYSTEM				
Parameter	Adjustment range	Description	Factory setting	Customer setting
INSTALLATION	TRADITIONAL	Displays the parameters of a conventional installation	TRADITIONAL	
	EXTENDED	Displays all parameters		

-  Regardless of what is done to the keys, the regulator switches back to **TRADITIONAL** mode after 30 minutes.

5.5.2. Setting the heating pump speed on the heat pump

The setting is used to select the speed of the primary pump located between the condenser and the tank, according to the output of the outside module; it is important to guarantee correct running of the heat pump.

1. Access the installer level: Press key  for around 5 seconds.
2. Select the menu **#PRIMARY LIMITS**:

-  Turn the rotary button to scroll through the menus or modify a value.
-  Press the rotary button to access the selected menu or confirm a value modification.

 For a detailed explanation of menu browsing, refer to the chapter: "Browsing in the menus", page 80.

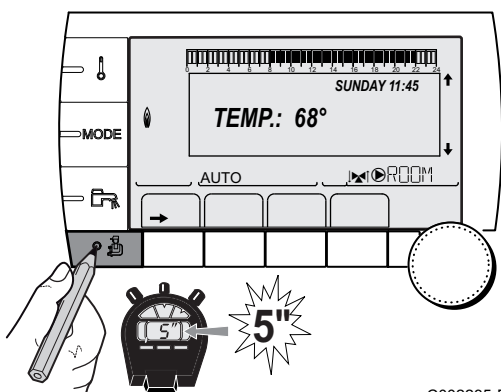

C002235-F-04

Installer level - Menu #PRIMARY LIMITS				
Parameter	Adjustment range	Description	Factory setting	Customer setting
MHR.PUMP SPEED (1)	1 - 5	Speed of the heat pump heating pump	3	<ul style="list-style-type: none"> ▶ 1: 4, 6 kW ▶ 2: 8, 11 kW ▶ 4: 16 kW ▶ 5: 22, 27 kW

(1) The menu is displayed only if the **INSTALLATION** parameter is set to **EXTENDED**

5.5.3. Setting the flow rate threshold

Setting the flow rate threshold is used to select the threshold below which the heat pump goes into safety shutdown. The flow rate threshold must be chosen according to the type of outside module (See table below).

1. Access the installer level: Press key  for around 5 seconds.
2. Select the menu **#PRIMARY INSTAL.P**:

-  ▶ Turn the rotary button to scroll through the menus or modify a value.
- ▶ Press the rotary button to access the selected menu or confirm a value modification.

 For a detailed explanation of menu browsing, refer to the chapter: "Browsing in the menus", page 80.

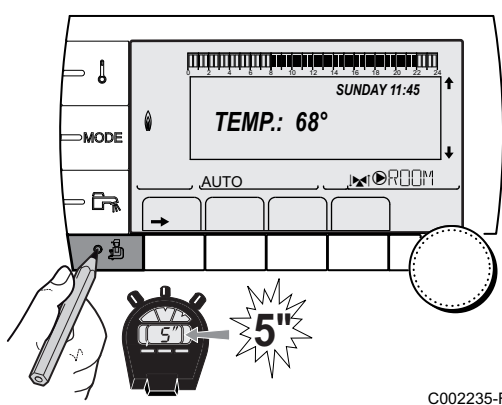

C002235-F-04

Installer level - Menu #PRIMARY INSTAL.P (1)				
Parameter	Adjustment range	Description	Factory setting	Customer setting
MIN.MES.FLOW.	OFF / 5 - 60	Flow rate limit below which a message is displayed indicating that the flow rate is low.  See chapter: "Messages", page 118.	25 l/mim.	
MIN.STOP.FLOW.	OFF / 5 - 60	Flow rate limit below which the heat pump goes into default. After 4 successive defaults, the system must be reset.	17 l/mim.	

(1) The menu is displayed only if the **INSTALLATION** parameter is set to **EXTENDED**

Type of group	MIN.MES.FLOW.	MIN.STOP.FLOW.
	l/min	l/min
4, 6 kW	12	8
8 kW	16	13
11 kW	19	13
16 kW	28	19
22, 27 kW	35	30



CAUTION

Check the water flow rate in the system, which must be higher by at least 4 to 5 l/min than the **MIN.MES.FLOW.** value. Check the parameter **FLOWMETER.**

See chapter: "Reading out measured values", page 94.

If the flow rate is too low, clean the filter upstream of the plate heat exchanger.

See chapter: "Cleaning the 400 µm filter", page 114.

5.5.4. Setting the parameters specific to the installation

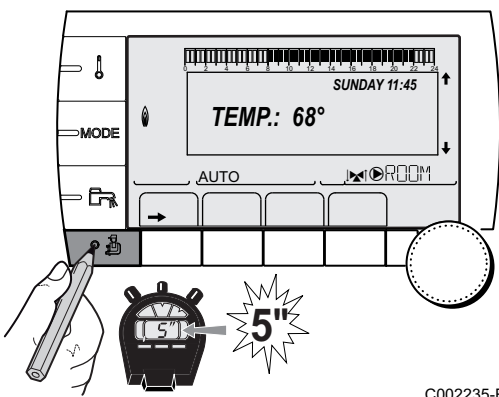

C002235-F-04

1. Access the installer level: Press key for around 5 seconds.
2. Select the menu **#SYSTEM.**



- ▶ Turn the rotary button to scroll through the menus or modify a value.
- ▶ Press the rotary button to access the selected menu or confirm a value modification.

For a detailed explanation of menu browsing, refer to the chapter: "Browsing in the menus", page 80

3. Set the following parameters according to the connections made to the PCBs:

Installer level - Menu #SYSTEM				
Parameter	Adjustment range	Description	Factory setting	Customer setting
CIRC.A (1) (2)	DIRECT	Use as a direct heating circuit (Radiator). Cooling is not possible.	DIRECT	
	HEATING FL.	Use as direct circuit on underfloor heating. Cooling is possible.		
	PROGRAM.	Use as an independent programmable outlet.		
	H.TEMP	Enables operation of circuit A in summer despite manual or automatic summer shutdown.		
	FAN CONVECTOR	Use as fan coil unit circuit. Cooling is possible.		
	DHW	Connection of a second domestic hot water tank.		
	DHW ELEC	Used to control the electrical resistor according to the timer programme on circuit A in summer mode.		
	DISAB.	No data for circuit A is displayed.		
(1) The parameter is only displayed if INSTALLATION is set to EXTENDED (2) If the pump incorporated in the boiler is used for circuit A (parameter CIRC.A set to DIRECT), the O.PUMP A outlet is free (3) The parameter is only displayed if the parameter O.PUMP A is set to CIRC.AUX or the 3-way valve PCB option is connected (4) The parameter is only displayed if a sensor is connected to the S.SYST inlet				

Installer level - Menu #SYSTEM				
Parameter	Adjustment range	Description	Factory setting	Customer setting
O.PUMP A ^{(1) (2)}	CH.PUMP A	Heating pump circuit A: The PUMP A outlet is used to control the pump on circuit A.	CH.PUMP A	
	CIRC.AUX	Used to resume the functions of the S.AUX parameter without adding the PCB + sensor option (Package AD249).		
	DHW LOOP	Used to control the domestic hot water looping pump according to the DHW timer programme and force its operation during an override.		
	PRIMARY PUMP	The outlet PUMP A is active if a heating demand is present on the secondary pump.		
	FAILURE	The outlet PUMP A is active if an fault is detected.		
	DEF.CASC	The Pump A outlet is active if a fault is present in the cascade.		
	VM P	The Pump A outlet is active if the VM pump is active.		
	COLD	The Pump A outlet is active in cold running.		
PUMP MIT/MHR	ALL	Runs if a circuit is required.	ALL	
	CIRC.A	Runs if A is required.		
CIRC.B ⁽¹⁾	3WV	Connecting a circuit with 3-way valve (For example: Underfloor heating).	3WV	
	SWIM.P.	Using the circuit for pool management.		
	FAN CONVECTOR	Use as fan coil unit circuit.		
CIRC.C ⁽¹⁾	3WV	Connecting a circuit with 3-way valve (For example: Underfloor heating).	3WV	
	SWIM.P.	Using the circuit for pool management.		
	FAN CONVECTOR	Use as fan coil unit circuit.		
P.DHW ⁽¹⁾	PUMP	Not used.	RV	
	RV	Not used.		
S.AUX ^{(1) (3)}	DHW LOOP	Use as a domestic loop pump.	DHW LOOP	
	PROGRAM.	Use as an independent programmable outlet.		
	PRIMARY PUMP	The outlet AUX PUMP is active if a heating demand is present on the secondary pump.		
	DHW	Use of primary circuit of second DHW tank.		
	FAILURE	The outlet AUX PUMP is active if a fault is detected.		
	DHW ELEC	Used to control the electrical resistor according to the timer programme on circuit AUX in summer mode.		
	COLD	The AUX Pump outlet is active in cold running.		
	VM P	The AUX Pump outlet is active if the VM pump is active.		
	DEF.CASC	The AUX Pump outlet is active if a fault is present in the cascade.		
I.SYST ^{(1) (4)}	SYSTEM	The inlet sensor is used to connect the common flow sensor of a cascade system.	SYSTEM	
	BUFFER TANK	Hot water storage tank affected to heating only.		
	DHW STRAT	Using the DHW tank with 2 sensors (top and bottom).		
	ST.TANK+DHW	Hot water storage tank affected to heating and domestic hot water.		
	DISAB.	Not used.		





(1) The parameter is only displayed if **INSTALLATION** is set to **EXTENDED**

(2) If the pump incorporated in the boiler is used for circuit A (parameter **CIRC.A** set to **DIRECT**), the **O.PUMP A** outlet is free

(3) The parameter is only displayed if the parameter **O.PUMP A** is set to **CIRC.AUX** or the 3-way valve PCB option is connected

(4) The parameter is only displayed if a sensor is connected to the **S.SYST** inlet

Installer level - Menu #SYSTEM				
Parameter	Adjustment range	Description	Factory setting	Customer setting
O.TEL ⁽¹⁾	FAILURE	The telephone outlet is closed in the event of failure.	FAILURE	
	REVISION	The telephone outlet is closed in the event of revision display.		
	DEF+REV	The telephone outlet is closed in the event of failure or revision display.		
CT.TEL ⁽¹⁾	CLOSE	See table below.	CLOSE	
	Open			
I.TEL ⁽¹⁾	ANTIFR	Boiler anti-freeze activation.	ANTIFR	
	0/1 A	ON or OFF contact: I.TEL: can be used as an antifreeze activation inlet on circuit A.		
	0/1 B	ON or OFF contact: I.TEL: can be used as an antifreeze activation inlet on circuit B.		
	0/1 A+B	ON or OFF contact: I.TEL: can be used as an antifreeze activation inlet on circuits A+B		
	0/1 C	ON or OFF contact: I.TEL: can be used as an antifreeze activation inlet on circuit C.		
	0/1 A+C	ON or OFF contact: I.TEL: can be used as an antifreeze activation inlet on circuits A+C		
	0/1 B+C	ON or OFF contact: I.TEL: can be used as an antifreeze activation inlet on circuits B+C		
	0/1 A+B+C	ON or OFF contact: I.TEL: can be used as an antifreeze activation inlet on circuits A+B+C		
	0/1 DHW	ON or OFF contact: I.TEL: can be used as an antifreeze activation inlet on circuit ECS.		
I.TEL ⁽¹⁾	0/1 A+DHW	ON or OFF contact: I.TEL: can be used as an antifreeze activation inlet on circuits A+ECS	ANTIFR	
	0/1 B+DHW	ON or OFF contact: I.TEL: can be used as an antifreeze activation inlet on circuits B+ECS		
	0/1 A+B+DHW	ON or OFF contact: I.TEL: can be used as an antifreeze activation inlet on circuits A+B+ECS		
	0/1 C+DHW	ON or OFF contact: I.TEL: can be used as an antifreeze activation inlet on circuits C+ECS		
	0/1 A+C+DHW	ON or OFF contact: I.TEL: can be used as an antifreeze activation inlet on circuits A+C+ECS		
	0/1 B+C+DHW	ON or OFF contact: I.TEL: can be used as an antifreeze activation inlet on circuits B+C+ECS		
	0/1 AUX	ON or OFF contact: I.TEL can be used as an antifreeze activation inlet on circuit AUX (S.AUX if the AD 249 option is connected or the parameter O.PUMP A is set to CIRC.AUX). When I.TEL is not activated, the auxiliary circuit (AUX) follows the maximum temperature of the inside module (parameter MAX MIT).		
	0/1 EVU	ON or OFF contact: Enables you to use I.TEL as an EVU power cut off inlet.		
	IN 0-10V	Enables use of I.TEL as the input for a 0–10 V command.		
<p>(1) The parameter is only displayed if INSTALLATION is set to EXTENDED</p> <p>(2) If the pump incorporated in the boiler is used for circuit A (parameter CIRC.A set to DIRECT), the O.PUMP A outlet is free</p> <p>(3) The parameter is only displayed if the parameter O.PUMP A is set to CIRC.AUX or the 3-way valve PCB option is connected</p> <p>(4) The parameter is only displayed if a sensor is connected to the S.SYST inlet</p>				

Influence of the parameter setting CT.TEL on the I.TEL contact			
CT.TEL	I.TEL	I.TEL contact closed	I.TEL contact open
CLOSE	ANTIFR	The antifreeze mode is active on all circuits. The heating system is off.	The mode selected on the inside module is active.
	0/1 A	The mode selected on the circuit is active.	The antifreeze mode is active on the circuit concerned.
	0/1 B	The mode selected on the circuit is active.	The antifreeze mode is active on the circuit concerned.
	0/1 C	The mode selected on the circuit is active.	The antifreeze mode is active on the circuit concerned.
	0/1 DHW	The mode selected on the DHW circuit is active.	The antifreeze mode is active for the DHW circuit.
	0/1 AUX	<ul style="list-style-type: none"> ▶ The AUX outlet on the connection terminal block is active. ▶ The device operates with a set point temperature equal to MAX MIT. 	<ul style="list-style-type: none"> ▶ The AUX outlet on the connection terminal block is not active. ▶ The device operates with a set point temperature dependent on the outside temperature.
	0/1 EVU	No EVU power cut off	The heat pump and back-ups are cut off. The buffer tank meets the heating needs.
Open	ANTIFR	The mode selected on the inside module is active.	The antifreeze mode is active on all circuits. The heating system is off.
	0/1 A	The antifreeze mode is active on the circuit concerned.	The mode selected on the circuit is active.
	0/1 B	The antifreeze mode is active on the circuit concerned.	The mode selected on the circuit is active.
	0/1 C	The antifreeze mode is active on the circuit concerned.	The mode selected on the circuit is active.
	0/1 DHW	The antifreeze mode is active for the DHW circuit.	The mode selected on the DHW circuit is active.
	0/1 AUX	<ul style="list-style-type: none"> ▶ The AUX outlet on the connection terminal block is not active. ▶ The device operates with a set point temperature dependent on the outside temperature. 	<ul style="list-style-type: none"> ▶ The AUX outlet on the connection terminal block is active. ▶ The device operates with a set point temperature equal to MAX MIT.
	0/1 EVU	The heat pump and back-ups are cut off. The buffer tank meets the heating needs.	No EVU power cut off

■ Power cut off (EVU)

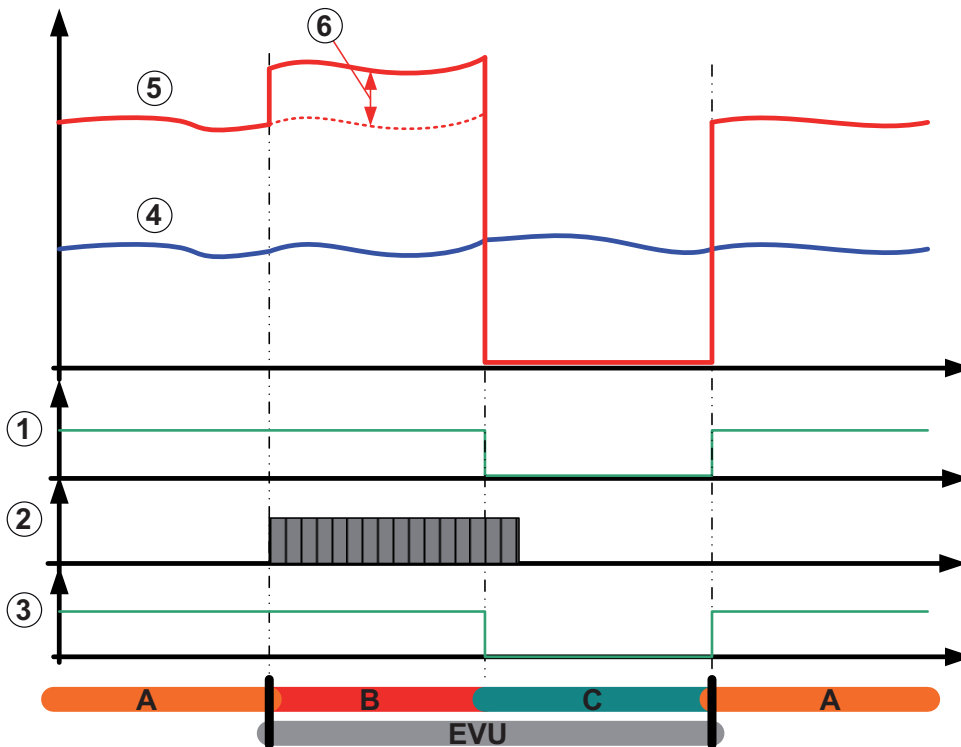

M002702-A

- ① Circulator
- ② **EVU** power cut off timer program
- ③ Compressor
- ④ Outside temperature
- ⑤ Temperature set point
- ⑥ Temperature **OFFSET EVU** (0 to 20 K)
- A** Phase A (👉 See below)
- B** Phase B (👉 See below)
- C** Phase C (👉 See below)
- EVU** **EVU** function

Phase A	Normal operation according to the DHW and ECO / COMFORT timer programme.
Phase B	Start-up of the EVU timer programme. The set point temperature on the inside module is increased by the value shown in the OFFSET EVU parameter as long as the EVU timer programme is active and the EVU signal is absent (the EVU contact is closed). Domestic hot water production can only be handled if the tank has an electrical resistor.
Phase C	Presence of the EVU signal (the EVU contact is open). The outside module, the back-ups and the heating pumps on the inside module are powered down. The secondary pumps continue to run as long as the circuits concerned are required. No DHW production enabled.

5.5.5. Naming the circuits and generators

1. Access the installer level: Press key  for around 5 seconds.
2. Select the menu **#NAMES OF THE CIRCUITS**.

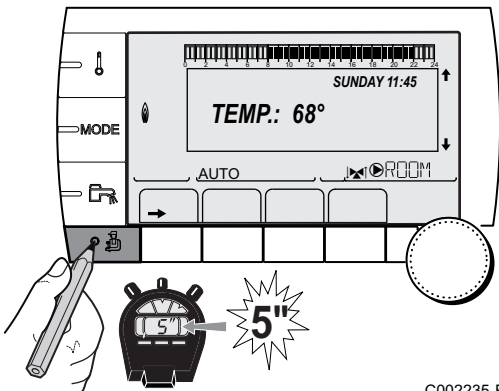

C002235-F-04

- i** Turn the rotary button to scroll through the menus or modify a value.
 - Press the rotary button to access the selected menu or confirm a value modification.
-  For a detailed explanation of menu browsing, refer to the chapter: "Browsing in the menus", page 80

3. Select the circuit or generator you wish to rename.

Installer level - Menu #NAMES OF THE CIRCUITS		
Parameter	Description	Name given by the customer
CIRC.A	Circuit A	
CIRC.B	Circuit B	
CIRC.C	Circuit C	
CIRC.AUX	Auxiliary circuit	
CIRC.DHW	Domestic hot water circuit	
GENE	Generator	

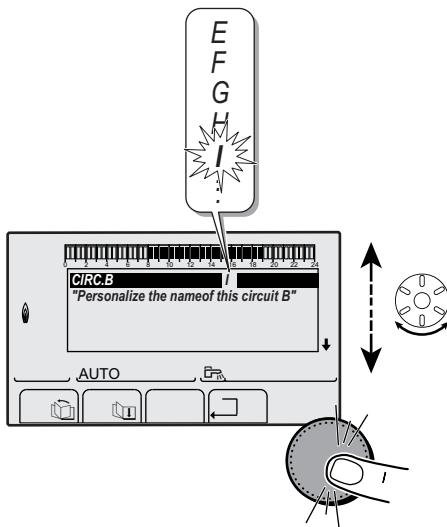

C002344-E-04

4. Turn the rotary button to choose the first character from the list. To confirm, press the rotary button.
5. Then press again to enter a second character or turn the rotary button to leave an empty space.
6. Choose the other characters in the same way. The input zone may contain up to 6 characters.

- i** To move from one character to another, turn the rotary button. To exit without modifications, press key **ESC**.

7. To confirm the name, press the rotary button and then turn the button slightly anti-clockwise. When the symbol  appears, press the rotary button. The name is confirmed.

- i** If the name reaches 6 characters, it is automatically confirmed when the last character is confirmed.

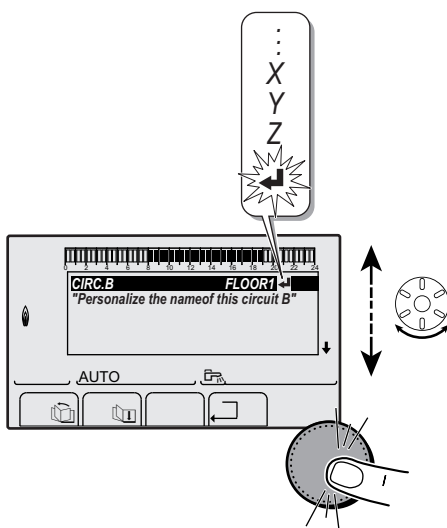

C002345-D-04

5.5.6. Setting the heating curve

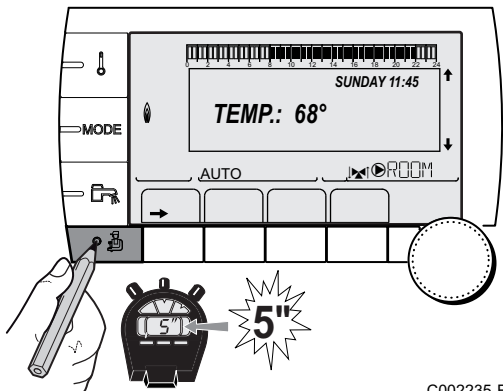

C002235-F-04

1. Access the installer level: Press key for around 5 seconds.
2. Select the menu **#SECONDARY INSTAL.PAL**).



- ▶ Turn the rotary button to scroll through the menus or modify a value.
- ▶ Press the rotary button to access the selected menu or confirm a value modification.

For a detailed explanation of menu browsing, refer to the chapter: "Browsing in the menus", page 80.

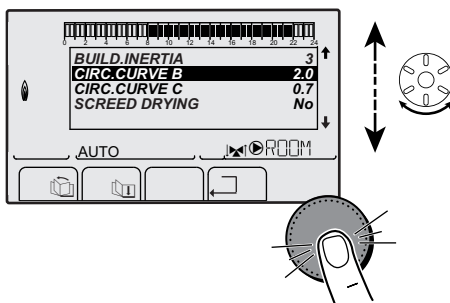

C002316-E-04

3. Select the parameter **CIRC.CURVE ...**

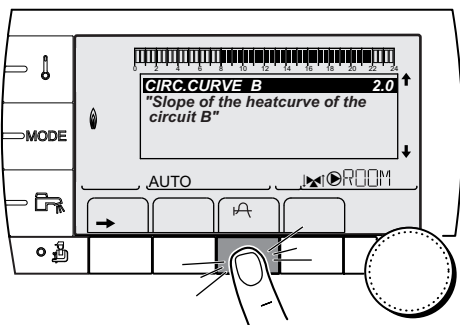

C002317-D-04

4. To modify the value directly, turn the rotary button.
To modify the value by displaying the curve, press key .

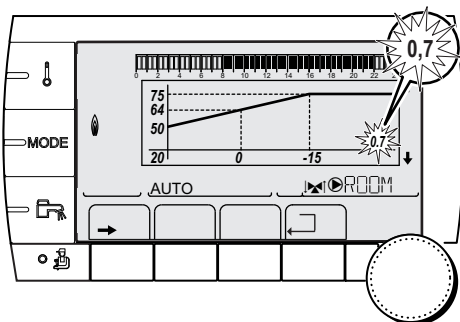

C002318-B-04

5. To modify the curve, turn the rotary button.
6. To confirm, press the rotary button.
To cancel, press key **ESC**.



0.7 = Heating curve set.

■ Heating curve without BCT

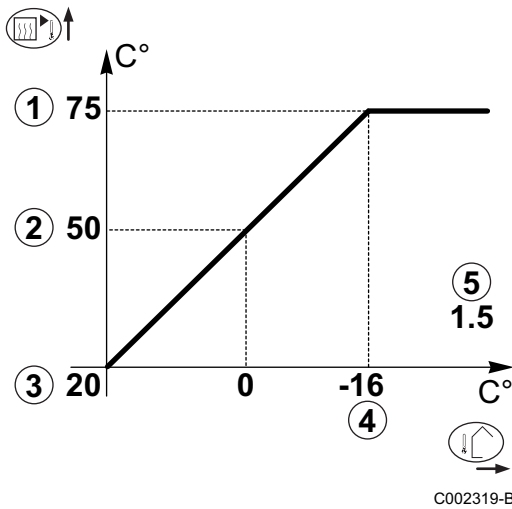

- ① Maximum temperature of the circuit
 - ② Water temperature in the circuit for an outside temperature of 0°C
 - ③ **DAY** set point on the circuit
 - ④ Outside temperature for which the maximum water temperature in the circuit is reached
 - ⑤ Value of the heating curve
Select the parameter **CIRC.CURVE ..**
- i** When you modify the heating curve, ② and ④ are recalculated and repositioned automatically.

■ Heating curve with BCT

The **BCT** (Base heat Curve Temperature) parameter allows a minimum operating temperature to be imposed on the heating circuit (this temperature may be constant if the circuit gradient is nil).

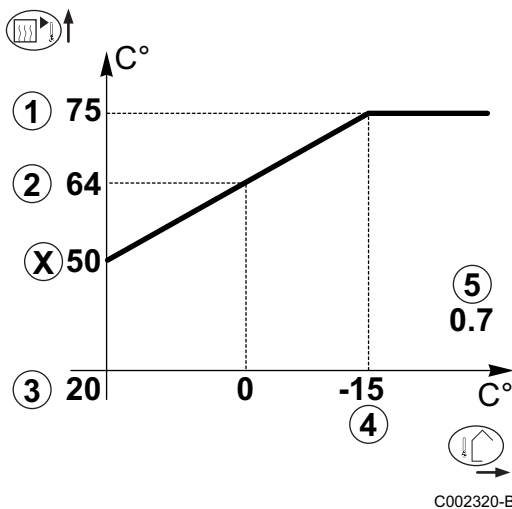

- ① Maximum temperature of the circuit
 - ② Water temperature in the circuit for an outside temperature of 0°C
 - ③ **DAY** set point on the circuit
 - ④ Outside temperature for which the maximum water temperature in the circuit is reached
 - ⑤ Value of the heating curve
Select the parameter **CIRC.CURVE ..**
 - x Value set to the parameter **HCZP D**
- i** When you modify the heating curve, ② and ④ are recalculated and repositioned automatically.

5.5.7. Setting the speed of the heating pump on the inside module

The setting is used to select the speed of heating pump A, located on the secondary tank circuit. The speed must be selected in such a way as to have a temperature differential between the flow and the return of 5 to 10 K when running at nominal output.

1. Access the installer level: Press key  for around 5 seconds.
2. Select the menu **#PRIMARY LIMITS**:



- ▶ Turn the rotary button to scroll through the menus or modify a value.
- ▶ Press the rotary button to access the selected menu or confirm a value modification.

 For a detailed explanation of menu browsing, refer to the chapter: "Browsing in the menus", page 80.

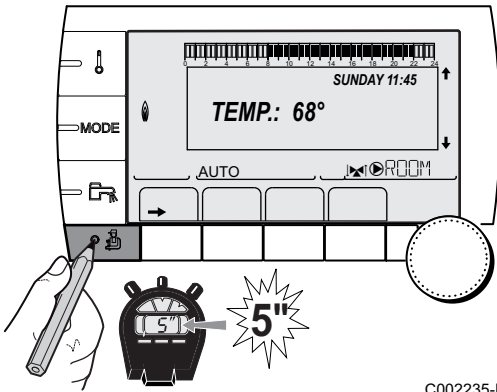

C002235-F-04

Installer level - Menu #PRIMARY LIMITS				
Parameter	Adjustment range	Description	Factory setting	Customer setting
PERCENT PUMP MIT ⁽¹⁾	1 - 5	Inside module pump speed	3	

(1) The menu is displayed only if the **INSTALLATION** parameter is set to **EXTENDED**



CAUTION

The integrated filter must be cleaned after one hour's operation on commissioning.

 "Cleaning the 400 µm filter", page 114.

5.6 Reading out measured values

The various values measured by the appliance are displayed in the **#MEASURES** menu.

1. To access user level: Press the **→** key.
2. Select the menu **#MEASURES**.



- ▶ Turn the rotary button to scroll through the menus or modify a value.
- ▶ Press the rotary button to access the selected menu or confirm a value modification.

 For a detailed explanation of menu browsing, refer to the chapter: "Browsing in the menus", page 80.

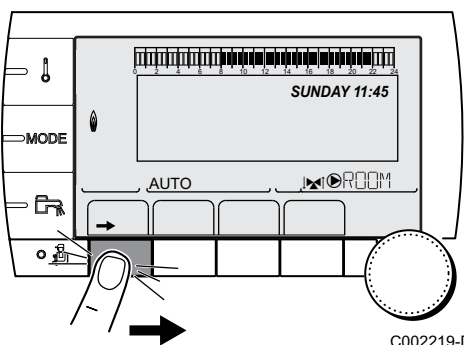

C002219-D-04

User level - Menu #MEASURES		
Parameter	Description	Unit
OUTSIDE TEMP.	Outside temperature	°C
ROOMTEMP.A ⁽¹⁾	Room temperature of circuit A	°C
ROOMTEMP.B ⁽¹⁾	Room temperature of circuit B	°C
ROOMTEMP.C ⁽¹⁾	Room temperature of circuit C	°C
MIT TEMP.	Inside module flow sensor measurement	°C
PRESSURE	Water pressure in the installation	bar (MPa)
WATER TEMP. ⁽¹⁾	Water temperature in the DHW tank	°C
STOR.TANK.TEMP ⁽¹⁾	Water temperature in the storage tank	°C
SWIMMING P.T.B ⁽¹⁾	Water temperature of the swimming pool on circuit B	°C
SWIMMING P.T.C ⁽¹⁾	Water temperature of the swimming pool on circuit C	°C
OUTLET TEMP.B ⁽¹⁾	Temperature of the flow water in circuit B	°C
OUTLET TEMP.C ⁽¹⁾	Temperature of the flow water in circuit C	°C
TEMP.SYSTEM ⁽¹⁾	Temperature of the system flow water if multi-generator	°C
T.DHW BOTTOM ⁽¹⁾	Water temperature in the bottom of the DHW tank	°C
TEMP.TANK AUX ⁽¹⁾	Water temperature in the second DHW tank connected to the AUX circuit	°C
DHW A TEMP. ⁽¹⁾	Water temperature in the second DHW tank connected to circuit A	°C
TEMP.SOL.TANK ⁽¹⁾	Temperature of the hot water produced by solar power (TS)	°C
SOLAR.COLL.T. ⁽¹⁾	Solar panel temperature (TC)	°C
SOLA.ENERGY ⁽¹⁾	Solar energy accumulated in the tank	kWh
FLOWMETER	Plate exchanger flow rate	l/min
NB IMPULS.COMP	Number of heat pump start-ups	
RUNTIME HP	Number of hours' operation of the heat pump compressor	h
IN 0-10V ⁽¹⁾	Voltage at input 0-10 V	V
SEQUENCE	Control system sequence	
CTRL	Software control number (SCU)	
DT INSTALLATION	Installation temperature delta	K
ELEC.ENERGY ⁽¹⁾	Total electrical energy consumed	kWh
ELEC.ENERG.Y1 ⁽¹⁾	Total electrical energy consumed in the previous year	kWh
ELEC.ENERG.Y2 ⁽¹⁾	Total electrical energy consumed two years ago	kWh
THERM.ENERGY ⁽¹⁾	Total thermal energy yield	kWh
THERM.ENERG.Y1 ⁽¹⁾	Total thermal energy yield in the previous year	kWh
THERM.ENERG.Y2 ⁽¹⁾	Total thermal energy yield two years ago	kWh

(1) The parameter is only displayed for the options, circuits or sensors actually connected.

5.7 Changing the settings

The heat pump control panel is set for the most common heating installations. With these settings, practically all heating systems operate correctly. The user or installer can optimise the parameters according to own preferences.

 For the user settings, refer to the user instructions.

5.7.1. Language selection

1. Access the installer level: Press key  for around 5 seconds.
2. Select the menu **#LANGUAGE**.



- ▶ Turn the rotary button to scroll through the menus or modify a value.
- ▶ Press the rotary button to access the selected menu or confirm a value modification.

 For a detailed explanation of menu browsing, refer to the chapter: "Browsing in the menus", page 80

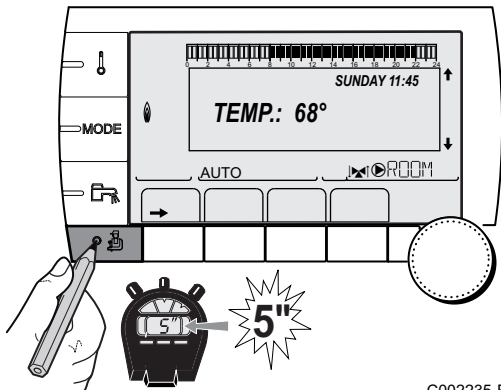

C002235-F-04

Installer level - Menu #LANGUAGE	
Adjustment range	Description
FRANCAIS	Display in French
DEUTSCH	Display in German
ENGLISH	Display in English
ITALIANO	Display in Italian
ESPANOL	Display in Spanish
NEDERLANDS	Display in Dutch
POLSKI	Display in Polish
РУССКИЙ	Display in Russian
TÜRK	Display in Turkish

5.7.2. Calibrating the sensors

1. To access user level: Press the **→** key.
2. Select the menu **#SETTING**.



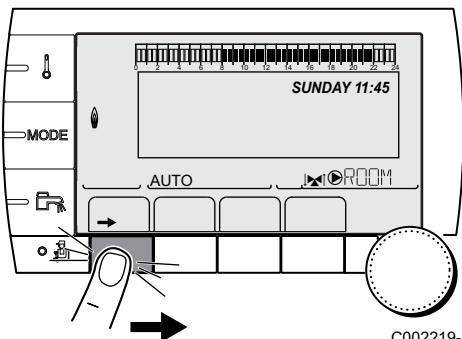

- ▶ Turn the rotary button to scroll through the menus or modify a value.
- ▶ Press the rotary button to access the selected menu or confirm a value modification.

 For a detailed explanation of menu browsing, refer to the chapter: "Browsing in the menus", page 80



C002219-D-04

3. Set the following parameters:

User level - Menu #SETTING				
Parameter	Adjustment range	Description	Factory setting	Customer setting
SUM/WIN	15 to 30 °C	Used to set the outside temperature above which heating will be shut down. <ul style="list-style-type: none"> ▶ The heating pumps are shut down. ▶ The heat pump only starts up for domestic hot water needs. ▶ In this case the letter E and symbol  are displayed. 	22 °C	
	NO	Heating is never shut down automatically		
CALIBR.OUT		Outside sensor calibration: Used to correct the outside temperature	Outside temperature	
CALIBR.ROOM A ⁽¹⁾		Calibration of the room sensor on circuit A Make this setting 2 hours after switching on, when the room temperature has stabilised	Room temperature of circuit A	
OFFSET ROOM A ⁽²⁾	-5.0 to +5.0 °C	Room offset on circuit A: Is used to set a room offset Make this setting 2 hours after switching on, when the room temperature has stabilised	0.0	
ANTIFR.ROOM A	0.5 to 20 °C	Room temperature antifreeze activation on circuit A	6 °C	
CALIBR.ROOM B ⁽¹⁾ ⁽³⁾		Calibration of the room sensor on circuit B Make this setting 2 hours after switching on, when the room temperature has stabilised	Room temperature of circuit B	
OFFSET ROOM B ⁽²⁾ ⁽³⁾	-5.0 to +5.0 °C	Room offset on circuit B: Is used to set a room offset Make this setting 2 hours after switching on, when the room temperature has stabilised	0.0	
ANTIFR.ROOM B ⁽³⁾	0.5 to 20 °C	Room temperature at which the antifreeze mode is activated on circuit B	6 °C	
CALIBR.ROOM C ⁽¹⁾ ⁽³⁾		Calibration of the room sensor on circuit C Make this setting 2 hours after switching on, when the room temperature has stabilised	Room temperature of circuit C	
OFFSET ROOM C ⁽²⁾ ⁽³⁾	-5.0 to +5.0 °C	Room offset on circuit C: Is used to set a room offset Make this setting 2 hours after switching on, when the room temperature has stabilised	0.0	
ANTIFR.ROOM C ⁽³⁾	0.5 to 20 °C	Room temperature antifreeze activation on circuit C	6 °C	
COST HIGH TARIFF ⁽⁴⁾	€ 0.01 to € 2.50	Cost of peak time electrical energy.	0.13	
COST HIGH TARIFF ⁽⁴⁾	€ 0.01 to € 2.50	Cost of off-peak electrical energy. The tariff is only factored in if parameter E. BL is set to HP/HC and the contact on the BL input is closed.  "Professional settings", page 98	0.09	
COST GAS.OIL ⁽⁴⁾	€ 0.01 to € 2.50	Cost of fossil energy (oil or gas). (Price per litre or m ³)	0.90	
<p>(1) The parameter is only displayed if a room sensor is connected to the circuit concerned</p> <p>(2) The parameter is only displayed if no room sensor is connected to the circuit concerned or the sensor has no influence</p> <p>(3) The parameter is only displayed if the circuit concerned is actually connected</p> <p>(4) The parameter is only displayed if HYBRID ENABLED is set to COST</p>				

5.7.3. Professional settings

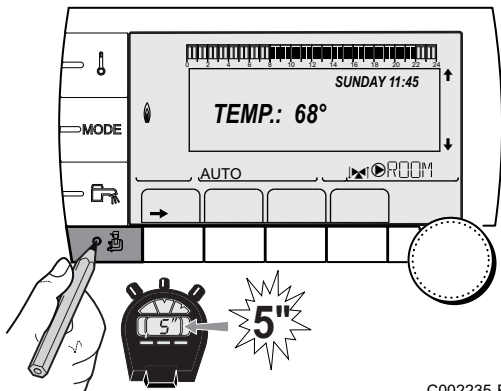



C002235-F-04





1. Access the installer level: Press key  for around 5 seconds.
2. Set the following parameters:



- ▶ Turn the rotary button to scroll through the menus or modify a value.
- ▶ Press the rotary button to access the selected menu or confirm a value modification.

 For a detailed explanation of menu browsing, refer to the chapter: "Browsing in the menus", page 80.

Installer level - Menu #PRIMARY LIMITS				
Parameter	Adjustment range	Description	Factory setting	Customer setting
MAX MIT	20 to 79 °C	Maximum temperature of the MIT	4 to 16 kW: 65 °C 22 and 27 kW: 60 °C	
MAX HP (1)	20 to 79 °C	Maximum heat pump temperature	4 to 16 kW: 65 °C 22 and 27 kW: 60 °C	
PERCENT PUMP MIT (1)	 See chapter: "Setting the speed of the heating pump on the inside module", page 94			
MHR.PUMP SPEED (1)	 See chapter: "Setting the heating pump speed on the heat pump", page 84			
STOP HP: (1)	-20 to +5 °C	Heat pump shutdown temperature	-15 °C	
TEMP MIN DEFRO. (1)	25 to 40 °C	Minimum defrosting temperature	25 °C	
BIVALENCE.TEMP (1)	-10 to +20 °C	Temperature at the bivalence point	10 °C	
(1) The parameter is only displayed if INSTALLATION is set to EXTENDED				

Installer level - Menu #SECONDARY LIMITS			
Parameter	Adjustment range	Description	Factory setting
MAX.CIRC.A	30 to 95 °C	Maximum temperature (Circuit A)  "MAX.CIRC...", page 105	75 °C
MAX.CIRC.B	20 to 95 °C	Maximum temperature (Circuit B)  "MAX.CIRC...", page 105	50 °C
MAX.CIRC.C	20 to 95 °C	Maximum temperature (Circuit C)  "MAX.CIRC...", page 105	50 °C
OUT.ANTIFREEZE	OFF, -8 to +10 °C	Outside temperature at which the installation's antifreeze protection is activated. Below this temperature the pumps are permanently on and the minimum temperatures for each circuit are respected. When NIGHT :STOP is set, the reduced temperature is maintained in each circuit (Menu #SECONDARY INSTAL.P). OFF : Antifreeze protection is not activated	+3 °C
HCZP D A (1) (2)	OFF, 20 to 90 °C	Curve base temperature in Daytime mode (Circuit A)	OFF
HCZP N A (1) (2)	OFF, 20 to 90 °C	Curve base temperature in Nighttime mode (Circuit A)	OFF
HCZP D B (1) (2)	OFF, 20 to 90 °C	Curve base temperature in Daytime mode (Circuit B)	OFF
HCZP N B (1) (2)	OFF, 20 to 90 °C	Curve base temperature in Nighttime mode (Circuit B)	OFF
(1) The parameter is only displayed if INSTALLATION is set to EXTENDED			
(2) The parameter can be set to the heating curve by pressing key  .			

Installer level - Menu #SECONDARY LIMITS			
Parameter	Adjustment range	Description	Factory setting
HCZP D C (1) (2)	OFF, 20 to 90 °C	Curve base temperature in Daytime mode (Circuit C)	OFF
HCZP N C (1) (2)	OFF, 20 to 90 °C	Curve base temperature in Nighttime mode (Circuit C)	OFF
PRIM.TEMP.DHW (1)	50 to 95 °C	Boiler temperature setting if producing domestic hot water	65 °C

(1) The parameter is only displayed if **INSTALLATION** is set to **EXTENDED**

(2) The parameter can be set to the heating curve by pressing key μ .

Installer level - Menu #PRIMARY INSTAL.PIMAIRE P.INSTAL} (1)				
Parameter	Adjustment range	Description	Factory setting	Customer setting
HP BUS	ROE OO/ROE+ ROI+ TOR	Type of communication with the heat pump	TOR	Keep the factory setting.
COOLING	OFF / ON / YES+DHW	Cooling	OFF	
SUM/WIN BAND (2)	2 to 10 °C	Neutral band in which the inside module is on standby	4 °C	
REVERS.DELAY (2)	10 to 48 hours	Hot/Cold time delay reversal	24 hours	
SUM/WIN	15 to 30 °C	Used to set the outside temperature above which heating will be shut down. <ul style="list-style-type: none"> ▶ The heating pumps are shut down. ▶ The heat pump only starts up for domestic hot water needs. ▶ In this case the letter E and symbol μ are displayed. 	22 °C	
	NO	Heating is never shut down automatically		
HP PUMP DELAY	0 to 30 min	Post-operating time of the heating pump on the heat pump	1 mn	
DIFF.HP	1 to 10 °C	Set point differential on the heat pump	5 °C	
MINI STOP HP	3 to 30 min	Anti-short cycle time	3 mn	

(1) The menu is displayed only if the **INSTALLATION** parameter is set to **EXTENDED**

(2) The parameter is only displayed if the **COOLING** parameter is not set to **OFF**.

(3) The BL inlet must always be connected to a dry contact (potential-free)

(4) Active when the BL contact is opened.

(5) Active when the BL contact is closed.

(6) The parameter is only displayed if **HYBRID ENABLED** is set to **COST**

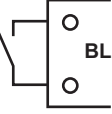

(7) The parameter is only displayed if **BACKUP TYPE** is set to /H

Installer level - Menu #PRIMARY INSTAL.PIMAIRE P.INSTAL} (1)				
Parameter	Adjustment range	Description	Factory setting	Customer setting
E. BL (3)  C004755-A	COMPLETE (4)	Total shutdown of the installation. Frost protection not guaranteed.	1: PARTIAL	
	PARTIAL (4)	Shutdown - Frost protection of the installation		
	USER RESET (5)	User reset		
	BACK-UP MIT (5)	Power cut off of the back-ups on the inside module		
	AUCUN-APP+PAC (5)	Power cut off of the back-ups on the inside module + Power cut off of the DHW tank back-ups + HP power cut off. The installation is stopped. Frost protection not guaranteed.		
	COMPRESSOR (5)	HP power cut off		
	BACK-UP MIT DHW (5)	Power cut off of the back-ups on the inside module + Power cut off of the DHW tank back-ups		
	DHW BACKUP (5)	Power cut off of the DHW tank back-ups		
	WWE.KOMP ZUSATZ. (5)	Power cut off of the DHW tank back-ups + HP power cut off		
	COMP.MIT BACKUP (5)	Power cut off of the back-ups on the inside module + HP power cut off		
	PEAK/PEAK OFF (6)	Use of electricity tariff COST HIGH TARIFF in hybrid running		
MIT.PUMP.DELAY	0 to 99 min	Post-operation time delay MIT pump	3 mn	
BACKUP TYPE	/E1 /E2 /H	Nature of back-ups /E1: 1 stage electrical back-up /E2: 2 stage electrical back-up /H: Hydraulic additional heating		
INDIVIDUAL.RELIEVE	OFF / ON	Power cut off generator 3	OFF	
BACKUP PUMP DEL. (7)	0 to 15 min	Post-operation time back-up pump	4 mn	
BACKUP ADD.DELAY	0 to 50 min	Additional time delay on tripping the back-ups	20 mn	
BACKUP BOOSTER DEL	0 to 10 min	Time delay between stages or time delay on tripping the back-ups	4 mn	
DHW BACKUP	TANK	Use of the electrical resistor in the tank for DHW back-up	MIT	
	MIT	Use of the inside module back-ups for DHW		
	MIT/D.COOL	Heating mode: Use of the inside module back-ups for DHW Cooling mode: Use of the electrical resistor in the tank for DHW back-up		
BOOSTER START DHW	0 to 50 min	DHW back-up trip time delay	5 mn	









(1) The menu is displayed only if the **INSTALLATION** parameter is set to **EXTENDED**
 (2) The parameter is only displayed if the **COOLING** parameter is not set to **OFF**.
 (3) The BL inlet must always be connected to a dry contact (potential-free)
 (4) Active when the BL contact is opened.
 (5) Active when the BL contact is closed.
 (6) The parameter is only displayed if **HYBRID ENABLED** is set to **COST**
 (7) The parameter is only displayed if **BACKUP TYPE** is set to **/H**

Installer level - Menu #PRIMARY INSTAL.PIMAIRE P.INSTAL} (1)				
Parameter	Adjustment range	Description	Factory setting	Customer setting
BOOSTER TIMER DHW	0 to 10 min	DHW back-up stages trip time delay	5 mn	
DHW TYPE	PRIMARY SECONDARY	Choice of the type of installation on the DHW circuit	SECONDARY	
DHW.PUMP DELAY	1 to 99 min	Post-operation time delay ECS pump	3 mn	
DIF.COLD DHW	0 to 30 °C	DHW temperature differential to activate the heat pump	4 to 16 kW: 15 °C 22 and 27 kW: 0 °C	
DHW DIFF.	1 to 30 °C	Temperature differential of the DHW tank to restart DHW production	4 to 16 kW: 30 °C 22 and 27 kW: 6 °C	
DHW OFFSET	5 to 30 °C	Overheating of the heat pump flow temperature for DHW production in Eco mode  BOOST DHW	5°C	
DHW PRODUCT DELAY	0 to 10 hours	Maximum duration of DHW production	4 to 16 kW: 6 hours 22 and 27 kW: 2 hours	
DELAY BETWEEN ECS	0 to 4 hours	Minimum time between two DHW production runs	2 hours	
BOOST DHW	OFF (Eco mode) ON (Boost mode)	Acceleration of DHW production systematically using the back-ups	OFF	
MINI PRESSURE	OFF / 0 to 6 bar	Minimum pressure to generate a lock-out	OFF	

(1) The menu is displayed only if the **INSTALLATION** parameter is set to **EXTENDED**
(2) The parameter is only displayed if the **COOLING** parameter is not set to **OFF**.
(3) The BL inlet must always be connected to a dry contact (potential-free)
(4) Active when the BL contact is opened.
(5) Active when the BL contact is closed.
(6) The parameter is only displayed if **HYBRID ENABLED** is set to **COST**
(7) The parameter is only displayed if **BACKUP TYPE** is set to **/H**

Installer level - Menu #SECONDARY INSTAL.P				
Parameter	Adjustment range	Description	Factory setting	Customer setting
BUILD.INERTIA (1)	0 (10 hours) to 10 (50 hours)	Characterisation of building's inertia: <ul style="list-style-type: none"> ▶ 0 for a building with low thermal inertia. ▶ 3 for a building with normal thermal inertia. ▶ 10 for a building with high thermal inertia. Modification of the factory setting is only useful in exceptional cases.	3 (22 hours)	
CIRC.CURVE A (2)	0 to 4	Heating curve of the circuit A  "CIRC.CURVE .." , page 105	1.5	
ROOM INFL.A (2)	0 to 10	Influence of room sensor A  "ROOM S.INFL" , page 106	3	
MINI COOLING A (3)	OFF , 7 to 22 °C	Flow set point for the circuit	10°C	

(1) The menu is displayed only if the **INSTALLATION** parameter is set to **EXTENDED**.
(2) The parameter can be set to the heating curve by pressing key μ .
(3) The parameter is only displayed if the circuit is configured to **3WV** or **FAN CONVECTOR** and the **COOLING** parameter is other than **OFF**.
(4) The parameter is only displayed if **SCREED DRYING** is different from **OFF**.
(5) The parameter is only displayed if the **IN 0-10V** parameter is not set to **NO**.
(6) The parameter is only displayed if a room sensor is connected.
(7) The parameter is only displayed if **P.DHW** is set to **PUMP**

Installer level - Menu #SECONDARY INSTAL.P				
Parameter	Adjustment range	Description	Factory setting	Customer setting
CIRC.CURVE B ⁽²⁾	0 to 4	Heating curve of the circuit B  "CIRC.CURVE ..", page 105	0.7	
ROOM INFL.B ⁽²⁾	0 to 10	Influence of room sensor B  "ROOM S.INFL", page 106	3	
MINI COOLING B ⁽³⁾	OFF , 11 to 22 °C	Flow set point for the circuit	18°C	
CIRC.CURVE C ⁽²⁾	0 to 4	Heating curve of the circuit C  "CIRC.CURVE ..", page 105	0.7	
ROOM INFL.C ⁽²⁾	0 to 10	Influence of room sensor C  "ROOM S.INFL", page 106	3	
MINI COOLING C ⁽³⁾	OFF , 11 to 22 °C	Flow set point for the circuit	18°C	
BAND WIDTH ⁽¹⁾	4 to 16 K	Control unit bandwidth for the 3-way valves. Option of increasing the bandwidth if the valves are rapid or of reducing it if they are slow.	12 K	
BOIL/3WV SHIFT	0 to 16 K	Minimum temperature divergence between the heat pump and the valves	4 K	
SCREED DRYING	NO, B, C, B+C	Drying the floor  "SCREED DRYING", page 106	NO	
START DRYING TEMP ⁽⁴⁾	20 to 50 °C	Scree drying start temperature	20 °C	
STOP DRYING TEMP ⁽⁴⁾	20 to 50 °C	Scree drying stop temperature	20 °C	
NB DAYS DRYING ⁽⁴⁾	1 to 99		1	
NIGHT	DEC.	The lower temperature is maintained (Night mode)  "NIGHT", page 107	DEC.	
	STOP	The boiler is stopped (Night mode)  "NIGHT", page 107		
IN 0-10V ⁽¹⁾	OFF / TEMPERATURE / POWER %	Activating the 0-10 V function  "Function 0-10 V", page 107	OFF	
VMIN/OFF 0-10V ^{(1) (5)}	0 to 10 V	Voltage corresponding to the instruction set minimum	0.5 V	
VMAX 0-10V ^{(1) (5)}	0 to 10 V	Voltage corresponding to the instruction set maximum	10 V	
CONS.MIN 0-10V ^{(1) (5)}	0 to 100	Minimum set point temperature or output	0	
CONS.MAX 0-10V ^{(1) (5)}	0 to 100	Maximum set point temperature or output	100	
H.PUMP DELAY	0 to 15 minutes	Timing of the shutdown of the heating pumps. The timed heating pump shutdown prevents the heat pump overheating.	4 minutes	

(1) The menu is displayed only if the **INSTALLATION** parameter is set to **EXTENDED**.
(2) The parameter can be set to the heating curve by pressing key **MA**.
(3) The parameter is only displayed if the circuit is configured to **3WV** or **FAN CONVECTOR** and the **COOLING** parameter is other than **OFF**.
(4) The parameter is only displayed if **SCREED DRYING** is different from **OFF**.
(5) The parameter is only displayed if the **IN 0-10V** parameter is not set to **NO**.
(6) The parameter is only displayed if a room sensor is connected.
(7) The parameter is only displayed if **P.DHW** is set to **PUMP**

Installer level - Menu #SECONDARY INSTAL.P				
Parameter	Adjustment range	Description	Factory setting	Customer setting
ADAPT ⁽⁶⁾	ON	Automatic adaptation of the heating curves for each circuit with a room sensor with an influence of >0.	OFF	
	OFF	The heating curves can only be modified manually.		
PRIORITY DHW	TOTAL	Interruption of pool heating and reheating during domestic hot water production.	TOTAL	
	SLIDING	Domestic hot water production and heating on the valve circuits if the available output is sufficient and the hydraulic connection allows.		
	NO	Heating and domestic hot water production in parallel if the hydraulic connection allows.		
LEG PROTEC		The anti legionella function acts to prevent the development of legionella in the dhw tank, these bacteria are responsible for legionellosis.	OFF	
	OFF	Antilegionella function not activated		
	DAILY	The tank is overheated every day from 4:00 o'clock to 5:00 o'clock		
	WEEKLY	The tank is overheated every Saturday from 4:00 o'clock to 5:00 o'clock		
OFFSET EVU	0 to 20 °C	Overheating flow temperature	7 °C	
OPTIM. DHW ⁽⁷⁾	OFF	The function is deactivated	OFF	
	BOILER.T.	When, in heating mode, the boiler temperature exceeds PRIM.TEMP.DHW by +3°C and DHW tank needs are not met, the domestic hot water load pump starts		
	TEMP.SYST	When, in heating mode, the system temperature exceeds PRIM.TEMP.DHW by +3°C and DHW tank needs are not met, the domestic hot water pump starts		
ON.DHW ⁽⁷⁾	OFF	The function is deactivated	OFF	
	BOILER.T.	In DHW mode, the DHW load pump starts up only if the boiler temperature is higher than the DHW TEMP. setpoint + 5°C		
	TEMP.SYST	In DHW mode, the DHW load pump starts up only if the system temperature is higher than the DHW TEMP. setpoint + 5°C		

(1) The menu is displayed only if the **INSTALLATION** parameter is set to **EXTENDED**.
(2) The parameter can be set to the heating curve by pressing key \curvearrowright .
(3) The parameter is only displayed if the circuit is configured to **3WV** or **FAN CONVECTOR** and the **COOLING** parameter is other than **OFF**.
(4) The parameter is only displayed if **SCREED DRYING** is different from **OFF**.
(5) The parameter is only displayed if the **IN 0-10V** parameter is not set to **NO**.
(6) The parameter is only displayed if a room sensor is connected.
(7) The parameter is only displayed if **P.DHW** is set to **PUMP**

Installer level - Menu #SUN ⁽¹⁾				
Parameter	Adjustment range	Description	Factory setting	Customer setting
DEC.SOLAR DHW	0 to 30 °C	Maximum drop in the DHW set point when the solar pump is running at 100%	5°C	
REFERENCE DT	10 to 20 °C	Temperature difference that the solar pump tries to maintain between the solar DHW sensor and the panel	10°C	
MAX.T.COLLECTOR	100 to 125 °C	Temperature of the panel above which the solar pump starts up. The pump does not operate if the temperature of the solar tank is higher than 80°C	100°C	
MAX TPS PUMP	1 to 5 min	Minimum operating duration of the solar pump at 100% on start-up	1 minute	
MIN.PUMP SPEED	50 to 100 %	Minimum speed of the solar pump	50%	
TUBE COLLECTOR	YES / NO	Set to YES if tubular collectors are used	NO	
MAX FLOW	0 to 20 l/min	Maximum flow rate of the solar pump  "MAX FLOW" , page 108	6.7 l/min.	

(1) The menu is only displayed if the solar control system is connected and the **INSTALLATION** parameter is set to **EXTENDED**

Installer level - Menu #ENERGY COUNTERS ⁽¹⁾				
Parameter	Adjustment range	Description	Factory setting	Customer setting
FLOWM.TYPE	FREQUENCY / VOLTAGE	Output signal type from the flowmeter used to meter energy	FREQUENCY	
FLOWM.LOC.	PCU 194 / SCU-S192 / NO	PCB to which the flowmeter is connected	PCU 194 (Keep the factory setting)	
FREQ.FLOW.SLOPE	0 to 999	Gradient "a" in the frequential output flowmeter type $Q = a F + b$	373	
FREQ.FLOW.OFFS.	0 to 1000	Offset "b" in the frequential output flowmeter type $Q = a F + b$	30	
VOLT.FLOW.SLOPE	0 to 1500	Gradient "a" in the voltage output flowmeter type $Q = a V + b$.	850	
VOLT.FLOW.OFFS	0 to 1000	Offset "b" in the voltage output flowmeter type $Q = a V + b$.	0	
GLYCOL	0 to 40 %	Antifreeze percentage	0%	
ELEC.PUL.VAL.1	0 to 1000	Pulse weight on electrical energy meter 1	1 Wh	
ELEC.PUL.VAL.2	0 to 1000	Pulse weight on electrical energy meter 2	1 Wh	
HEAT PUL.VAL.	0 to 1000	Pulse weight on thermal energy meter (Option)	1000 W	
BACKUP 1	0 to 20 kW	First stage output of the electrical back-up	0 kW	
BACKUP 2	0 to 20 kW	Second stage output of the electrical back-up	0 kW	
DHW RESISTOR	0 to 10 000 W	Resistor output of the DHW tank	2400 W	
RESET CNT.kWh	ON / OFF	RESETs the energy meters	OFF	

(1) The menu is only displayed if the "energy metering" option is connected and parameter **INSTALLATION** is set to **EXTENDED**

Installer level - Menu #HYBRID ⁽¹⁾				
Parameter	Adjustment range	Description	Factory setting	Customer setting
HYBRID ENABLED	OFF / COST / PRIM.EN / CO2	<ul style="list-style-type: none"> ▶ OFF: The hybrid control system is not activated. ▶ COST: The hybrid control system optimises running according to energy costs. ▶ PRIM.EN: The hybrid control system optimises running according to primary energy consumption. ▶ CO2: The hybrid control system optimises running according to the quantity of CO₂ released. <p> "Hybrid function", page 108</p>	OFF	
BOIL.EFFICIENCY ⁽²⁾	0.5 to 1.5	Efficiency of the boiler connected as back-up.	1	
COEF.CO2.E.HEAT ⁽³⁾	0 to 1	Coefficient of carbon gas emissions from the heat pump in heating mode.	0.18	
COEF.CO2.E.DHW ⁽³⁾	0 to 1	Coefficient of carbon gas emissions from the heat pump in DHW mode.	0.04	
COEF.CO2.GAS.OIL ⁽³⁾	0 to 1	Coefficient of carbon gas emissions from the gas/oil boiler.	0.23	

(1) The menu is only displayed if a hydraulic back-up is used.
 (2) The parameter is only displayed if **HYBRID ENABLED** is set to **COST**
 (3) The parameter is only displayed if **HYBRID ENABLED** is set to **CO2**

■ **MAX.CIRC...**



WARNING

If using underfloor heating, do not modify the factory setting (50 °C). To install this, please consult existing legislation.

- ▶ In the case of a direct circuit, connect a safety thermostat to the BL contact.
- ▶ In the case of a 3-way valve circuit (B or C), connect a safety thermostat to the TS contact.

■ **CIRC.CURVE ..**

Heating curve circuit A, B or C

- x** Outside temperature (°C)
- y** Water flow temperature (°C)
- ① Maximum temperature of the circuit B - C

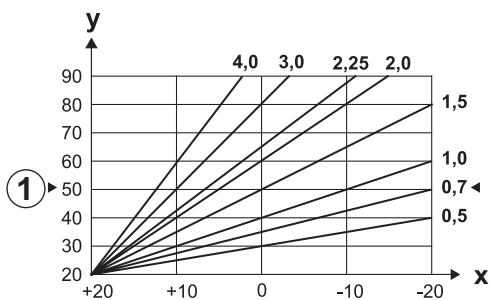

M001678-B

■ SCREED DRYING

Used to force a constant flow temperature or a train to accelerate screed drying on underfloor heating.

The setting for these temperatures must follow the screed-layer's recommendations.

The activation of this parameter (setting other than **OFF**) forces the permanent display of **SCREED DRYING** CHAPE} and deactivates all other functions on the control unit.

When floor drying is active on a circuit, all other circuits (e.g. DHW) are shut down. The use of this function is only possible on circuits B and C.

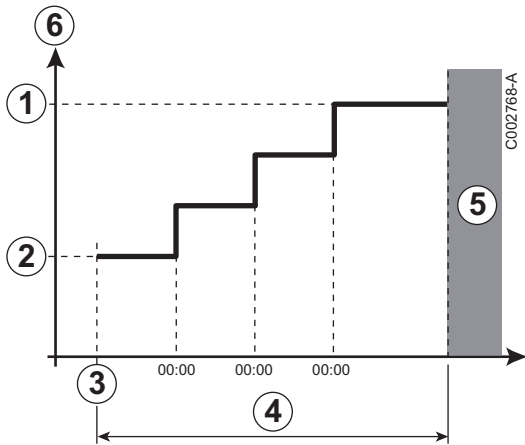

- ① **STOP DRYING TEMP**
- ② **START DRYING TEMP**
- ③ Today
- ④ **NB DAYS DRYING**
- ⑤ Normal regulation (End of drying)
- ⑥ Heating temperature setting (°C)

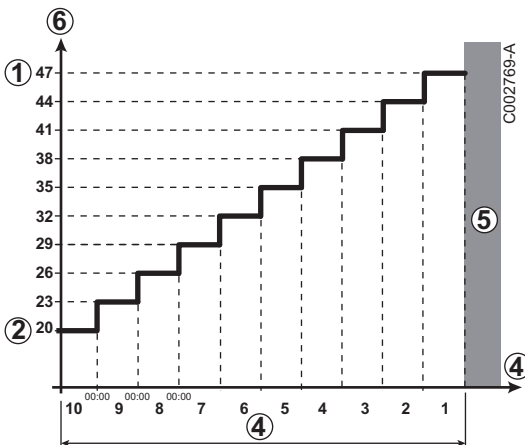

For example

- ① **STOP DRYING TEMP: 47 °C**
- ② **START DRYING TEMP: 20 °C**
- ④ **NB DAYS DRYING**
- ⑤ Normal regulation (End of drying)
- ⑥ Heating temperature setting (°C)



Every day at midnight (00:00): the set point (**START DRYING TEMP**) is recalculated and the remaining number of days (**NB DAYS DRYING**) is decremented.

■ ROOM S.INFL

Used to adjust the influence of the room sensor on the water temperature for the circuit concerned.

Adjustment	Description
0	No influence (remote control fitted in a location with no influence)
1	Slight influence
3	Average influence (recommended)
10	Room thermostat type operation

■ NIGHT



This parameter is displayed if at least one circuit does not include a room sensor.

For circuits without a room sensor:

- ▶ **NIGHT :DEC.** (Reduced): The reduced temperature is maintained during reduced periods. The circuit pump operates constantly.
- ▶ **NIGHT :STOP** (Stop): Heating is shut down during reduced periods. When installation antifreeze is active, the reduced temperature is maintained during reduced periods.

For circuits with a room sensor:

- ▶ When the room temperature is lower than the room sensor set point: The reduced temperature is maintained during reduced periods. The circuit pump operates constantly.
- ▶ When the room temperature is higher than the room sensor set point: Heating is shut down during reduced periods. When installation antifreeze is active, the reduced temperature is maintained during reduced periods.

■ Function 0-10 V

This function is used to command the heat pump through an external system comprising a 0-10 V outlet connected to the 0-10 V inlet on the SCU PCB. This command imposes a set point temperature on the heat pump. It will be necessary to ensure that the parameter **MAX MIT** is higher than **CONS.MAX 0-10V**.

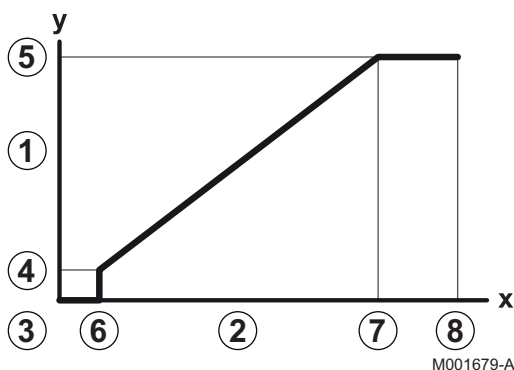

- 1 Instruction set outlet temperature (°C)
- 2 Input supply voltage (V) - DC
- 3 0 V
- 4 **CONS.MIN 0-10V**
- 5 **CONS.MAX 0-10V**
- 6 **VMIN/OFF 0-10V**
- 7 **VMAX 0-10V**
- 8 10 V
- x Voltage at input
- y Temperature of the heat pump

If the input voltage is less than **VMIN/OFF 0-10V**, the heat pump is off.

The heat pump set point temperature corresponds strictly to the 0-10 V inlet. The secondary circuits on the heat pump continue to run but have no effect on the heat pump's water temperature. If using the 0-10 V inlet and a secondary circuit on the heat pump, the external regulator supplying this 0-10 V voltage must always request a temperature at least equal to the needs of the secondary circuit.

■ MAX FLOW



In order for the regulator to calculate the quantity of heat produced by the installation (parameter kWh), input parameter **MAX FLOW**. The parameter **MAX FLOW** is equal to the flow in litres per minute in the solar circuit.

Establish the **MAX FLOW** value with the help of the table below, according to the configuration of the installation and the number or surface area of collectors.

When the flow is input incorrectly, the display kWh will also be incorrect.



The quantity of heat (kWh value) can only be used for checks carried out for personal reasons.

Flat solar collectors				
Solar panel installation	Area (m ²)	Number of panels	Flow rate (l/h)	Flow rate (l/min)
	3...5	1 or 2	400	6,7
	6...8	3 or 4	300	5,0
	8...10	4 or 5	250	4,1
	8...10	2x2	750	12,5
	12...15	2x3	670	11,2
	16...20	2x4	450	7,5
	12...15	3x2	850	14,2
	18...23	3x3	800	13,4
	24...30	3x4	650	10,9
	16...20	4x2	1200	20,0
	24...30	4x3	850	14,2

■ Hybrid function

The hybrid function consists of an automatic switch between the heat pump and an oil or gas boiler according to the changes in a factor previously selected by the user: consumption cost, quantity of energy consumed or carbon gas emission.

The switch between the heat pump and the boiler depends on the heat pump COP. The threshold COP is calculated according to parameters input by the user (cost, carbon gas emission coefficients). If the heat pump COP is higher than the threshold COP, the heat pump takes priority. Otherwise the boiler alone is enabled. The heat pump COP depends on the outside temperature.

The influence of temperatures **STOP HP:** and **BIVALENCE.TEMP** is described in the diagram opposite.

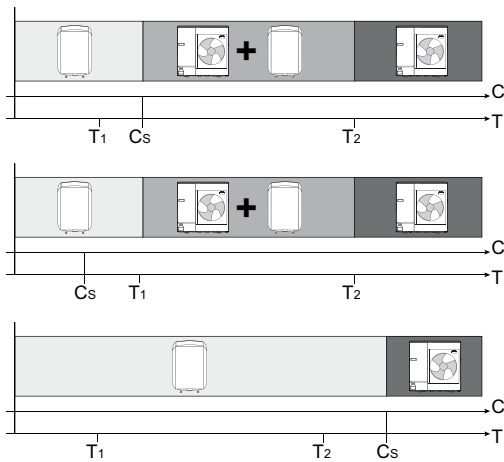

M003016-A

- C** COP: Performance coefficient
- Cs** Threshold coefficient of performance
- T** Outside temperature
- T1** Adjustment parameter **STOP HP:**
- T2** Adjustment parameter **BIVALENCE.TEMP**

5.7.4. Configuring the network

1. Access the installer level: Press key for around 5 seconds.
2. Select the menu **#NETWORK**.

- Turn the rotary button to scroll through the menus or modify a value.
- Press the rotary button to access the selected menu or confirm a value modification.

For a detailed explanation of menu browsing, refer to the chapter: "Browsing in the menus", page 80

3. Set the following parameters:

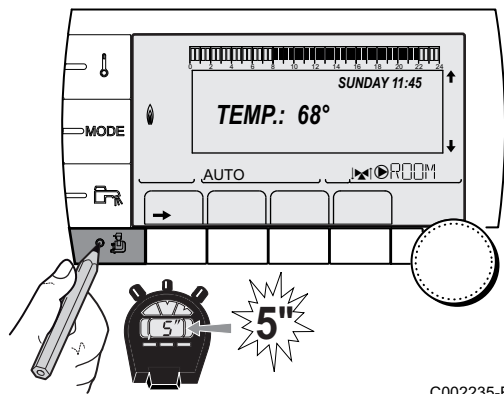

C002235-F-04

Installer level - Menu #NETWORK ⁽¹⁾				
Parameter	Adjustment range	Description	Factory setting	Customer setting
CASCADE	ON / NO	ON: System in cascade	NO	
VM NETWORK ⁽²⁾		Specific menu: Enlist VMs in cascade mode See chapter: "Connecting VM iSystem in cascade", page 111		
MASTER CONTROLER ⁽³⁾	ON / NO	Configure this control system as master on the bus	ON	
SYSTEM NETWORK ⁽⁴⁾		Specific menu: Enlist generators or VMs in cascade mode See chapter: "Connecting VM iSystem in cascade", page 111		

(1) The menu is displayed only if the **INSTALLATION** parameter is set to **EXTENDED**
 (2) The parameter is only displayed if **CASCADE** is set to **NO**
 (3) The parameter is only displayed if **CASCADE** is set to **ON**
 (4) The parameter is only displayed if **MASTER CONTROLER** is set to **ON**
 (5) The parameter is only displayed if **FUNCT** is set to **PARALLEL**
 (6) The parameter is only displayed if **MASTER CONTROLER** is set to **OFF**
 (7) According to the configuration

Installer level - Menu #NETWORK ⁽¹⁾				
Parameter	Adjustment range	Description	Factory setting	Customer setting
FUNCT ⁽⁴⁾	TRADITIONAL	Operation in cascade: Successive tripping of the various generators in the cascade according to needs	TRADITIONAL	
	PARALLEL	Functioning in parallel cascade: If the outside temperature is lower than the PARALLEL.CASC value, all generators are started up at the same time		
PARALLEL.CASC ⁽⁵⁾	-10 to 20 °C	Outside temperature triggering all stages in parallel mode	10 °C	
TIMER GENE P.CASC ⁽³⁾	0 to 30 min	Minimum duration of post-operation of the generator pump	0 mn	
INTER STAGE TIMER ⁽³⁾	1 to 60 min	Time delay for starting up or shutting down generators.	4 mn	
SLAVE NUMBER ⁽⁶⁾	2 to 10	Set the network address of the secondary generator	2	
VM NUMBER ⁽⁷⁾	20 to 39	Set the module's network address	20	

(1) The menu is displayed only if the **INSTALLATION** parameter is set to **EXTENDED**
 (2) The parameter is only displayed if **CASCADE** is set to **NO**
 (3) The parameter is only displayed if **CASCADE** is set to **ON**
 (4) The parameter is only displayed if **MASTER CONTROLLER** is set to **ON**
 (5) The parameter is only displayed if **FUNCT** is set to **PARALLEL**
 (6) The parameter is only displayed if **MASTER CONTROLLER** is set to **OFF**
 (7) According to the configuration

User level - Menu #SETTING				
Parameter	Adjustment range	Description	Factory setting	Customer setting
PERMUT ⁽¹⁾	AUTO / 1 ... 10	This parameter is used to set the master boiler. ▶ AUTO : The master boiler switches automatically every 7 days ▶ 1 ... 10: The master boiler is always the one defined by this value	AUTO	

(1) The parameter is only displayed if **CASCADE** is on **ON** and **MASTER CONTROLLER** on **ON**

■ Connecting appliances in cascade

It is possible, in a cascade configuration, to enlist generators and/or VM iSystem as slaves. Proceed as follows:

1. Set parameter **CASCADE** to **ON**.
2. Select **SYSTEM NETWORK** and press the rotary button to go to the specific menu.

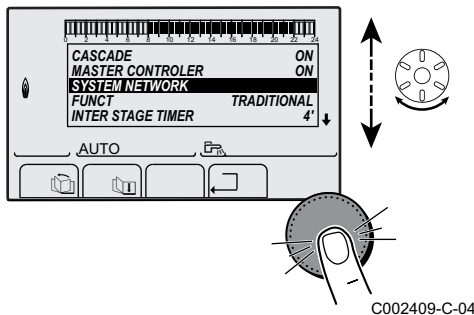

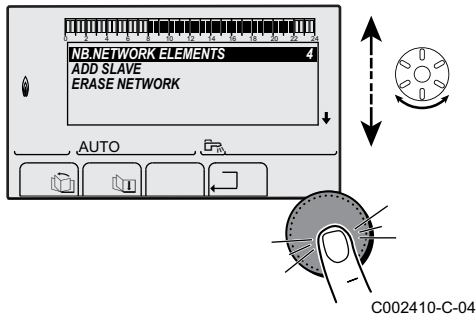

3. To add a slave appliance to the network, select **ADD SLAVE**.

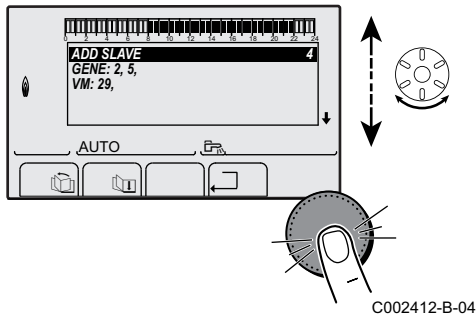

4. The screen displayed allows you to choose numbers for the slave boilers to be added to the network. Numbers 2 to 10 are dedicated to the generators and numbers 20 to 39 to the VM iSystem. Turn the rotary button to scroll through the numbers and press to confirm the number chosen. Press \square to go back to the previous list.

5. To remove a slave appliance from the network, select **ERASE NETWORK**.

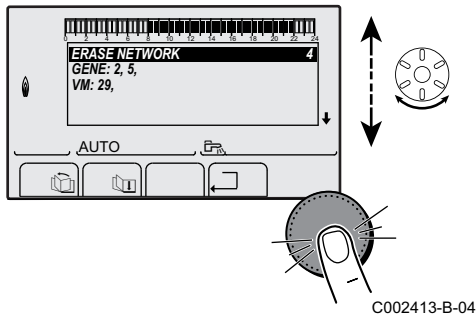

6. The screen displayed allows you to choose the numbers of the slave boilers to be removed from the network. Turn the rotary button to scroll through the numbers and press to remove the number chosen. Press \square to go back to the previous list.

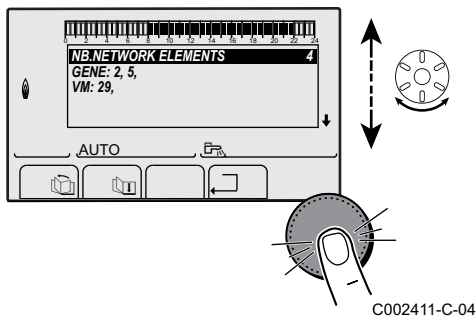

7. Select **NB.NETWORK ELEMENTS**. This screen summarises the elements in the network recognized by the system. Press \square to go back to the previous list.

■ Connecting VM iSystem in cascade

It is possible to assign VMs only as slaves. Proceed as follows:

1. Select **VM NETWORK** and press the rotary button to go to the specific menu.
2. The screen displayed is used to select the numbers of the slave VMs to be added to the network. Numbers 20 to 39 are dedicated to the VMs. Turn the rotary button to scroll through the numbers and press to confirm the number chosen. Press \square to go back to the previous list.
3. To remove a slave VM from the network, select **ERASE VM**.

4. The screen displayed is used to select the numbers of the slave VMs to be removed from the network. Turn the rotary button to scroll through the numbers and press to remove the number chosen. Press \square to go back to the previous list.
5. Select **NB.NETWORK ELEMENTS**. This screen summarises the elements in the network recognized by the system. Press \square to go back to the previous list.

5.7.5. Return to the factory settings

To reset the appliance, proceed as follows:

1. Press key \downarrow , \rightarrow and \square simultaneously for 4 seconds. The menu **#RESET** is displayed.
2. Set the following parameters:

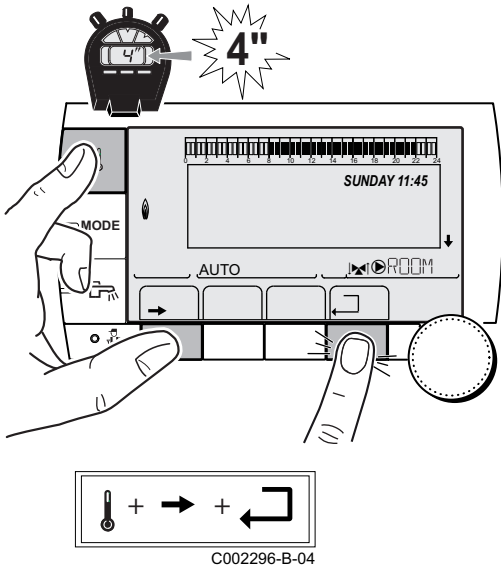

Menu #RESET			
Choice of generator	Parameter		Description
GENERATOR	RESET	TOTAL	Performs a TOTAL RESET of all parameters
		EXCEPT PROG.	Performs a parameter RESET but retains the timer programmes
		PROG.	Performs a RESET on the timer programmes but retains the parameters
		SENSOR SCU	Performs a RESET of the generator sensors connected
		ROOM SENSOR	Performs a RESET of the room sensors connected

After reset (**TOTAL RESET** and **RESET EXCEPT PROG.**), the control system goes back to the display of the language choice after a few seconds.

1. Select the desired language by turning the rotary button.
2. To confirm, press the rotary button.

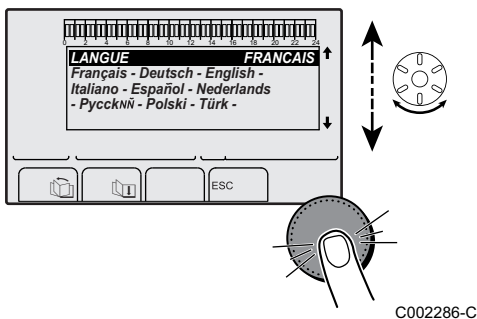

6 Switching off the appliance

6.1 Installation shutdown

If the central heating system is not used for a long period, we recommend switching the appliance off.

- ▶ To stop the inside module, use the  ON/OFF switch and cut the power supply to the home's junction box.
- ▶ To shut down the outside module, switch off the power supply on the junction box inside the house.



CAUTION

Antifreeze protection is no longer guaranteed automatically if the mains supply is switched off.

6.2 Turning on the antifreeze function

Put the heat pump into **HOLIDAYS** mode.  Refer to the user instructions.

7 Checking and maintenance

7.1 General instructions



CAUTION

- ▶ Maintenance operations must be done by a qualified engineer.
- ▶ An annual inspection is compulsory.
- ▶ Only original spare parts must be used.



Before carrying out any maintenance work requiring the shutdown of the inside module, also cut the power supply to the outside module to prevent any errors in communication.

7.2 Maintenance operations to be performed

An annual inspection with sealing control is compulsory. Schedule a **service in cold periods** to check the following points:

- ▶ Thermal output by measuring the temperature difference between the flow and the return.
- ▶ Check the watertightness of the connections using a leak detector.
- ▶ Check the watertightness of the water connections.

Preventive monitoring

- ▶ Check the performance of the heat pump: Temperature control.
- ▶ Check the water pressure in the installation.
- ▶ Check that the filters are not obstructed.
- ▶ Clean and dust the outdoor module.

7.3 Cleaning the 400 µm filter

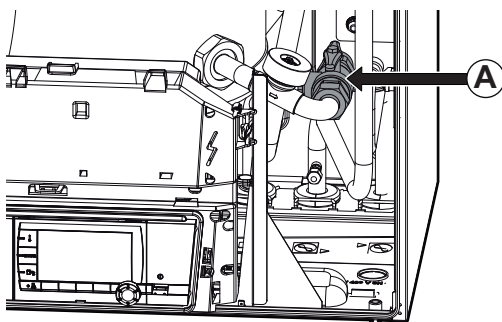

M002645-A

To prevent clogging in the plate exchanger, a 400 µm filter is located upstream of it. The filter is located in an isolating valve **A**.

Clean the filter:

- ▶ Clean the filter during the annual service.
- ▶ After the first hour's running on initial commissioning.
- ▶ If the flow rate drops (See table below).

Outside module output	Speed of the heat pump heating pump	Nominal water flow	Minimum flow rate recommended
		l/min	l/min
4, 6 kW	1	22	12
8 kW	2	26	16
11 kW	2	29	19
16 kW	4	38	28
22, 27 kW	5	41	35

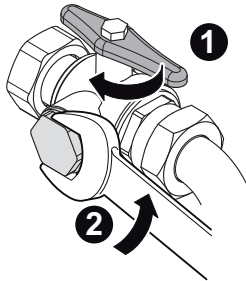

1. Close the valve on the exchanger.
2. Unscrew the cover.

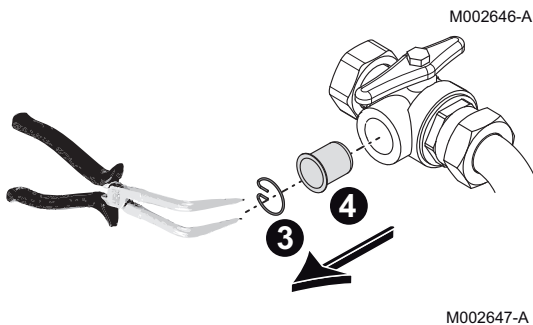

3. Dismantle the spring retaining ring.
4. Dismantle the filter.
5. Check and clean the filter.
Replace the filter if necessary.
6. Remount the filter.
7. Tighten the connection.
8. Open the valve on the exchanger.

7.4 Customising maintenance

7.4.1. Maintenance message

The heating generator includes a function used to display a maintenance message. To set the parameters for this function, proceed as follows:

1. Access the "After Sales" level: Hold down the key until **#PARAMETERS** is displayed.
2. Select the menu **#REVISION**.



- ▶ Turn the rotary button to scroll through the menus or modify a value.
- ▶ Press the rotary button to access the selected menu or confirm a value modification.

For a detailed explanation of menu browsing, refer to the chapter: "Browsing in the menus", page 80

3. Set the following parameters:

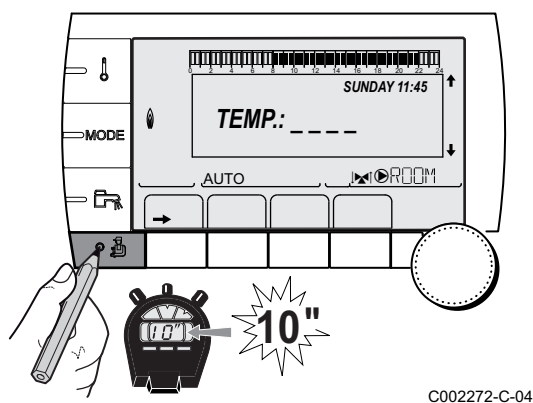

After Sales level - Menu #REVISION		
Parameter	Adjustment range	Description
REVISION TYPE	NO	Factory setting No message indicating that maintenance is necessary
	MANU	Recommended setting Signals that maintenance is necessary on the date selected. Set the date using the parameters below.
	AUTO	⚠ Not applicable. Do not select this setting.
REVISION HOUR ⁽¹⁾	0 to 23	Time at which the REVISION display appears
REV.YEAR ⁽¹⁾	2009 to 2099	Year in which the REVISION display appears
REVIS.MONTH ⁽¹⁾	1 to 12	Month in which the REVISION display appears
REVISION DATE ⁽¹⁾	1 to 31	Day on which the REVISION display appears

(1) The parameter is only displayed if **MANU** is configured.

Clearing the maintenance message:

After carrying out the maintenance operations, modify the date in the **#REVISION** menu to clear the message.

In the event of maintenance before the maintenance message is displayed:

After carrying out early maintenance operations, it is necessary to set a new date in the **#REVISION** menu.

7.4.2. Contact details of the professional for After Sales Support

In order to assist the user if an error or service message is displayed, it is possible to provide the contact details of the professional to be contacted. To input the professional's contact details, proceed as follows:

1. Access the "After Sales" level: Hold down the  key until **#PARAMETERS** is displayed.
2. Select the menu **#SUPPORT**.

-  Turn the rotary button to scroll through the menus or modify a value.
- ▶ Press the rotary button to access the selected menu or confirm a value modification.

 For a detailed explanation of menu browsing, refer to the chapter: "Browsing in the menus", page 80

3. Set the following parameters:

After Sales level - Menu #SUPPORT	
Parameter	Description
NAME	Input the installer's name
TEL	Input the installer's telephone number

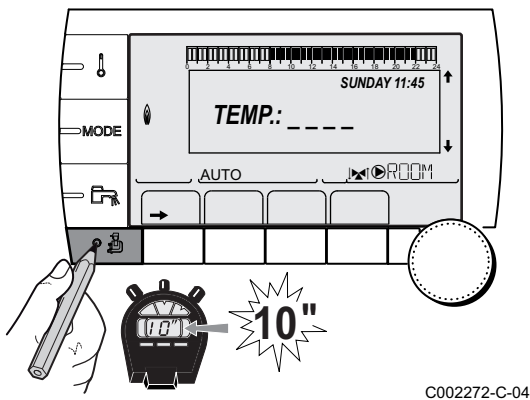

C002272-C-04

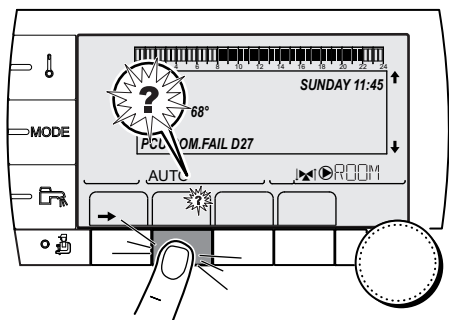

When the message **REVISION** is displayed, press ? to display the professional's telephone number.

C002302-D-04

8 Troubleshooting

8.1 Anti-hunting

When the heat pump is in "anti-short cycle" operating mode, the symbol "?" flashes. This is a normal operating mode. When the restart temperature is reached, operation will be guaranteed.

1. Press the "?" key.
The message **Operation assured when the restart temperature will be reached** is displayed. When the restart temperature is reached, operation will be guaranteed.





This message is not an error message but an item of information.

8.2 Messages

In the case of failure, the control panel displays a message and a corresponding code.

1. Make a note of the code displayed.
The code is important for the correct and rapid diagnosis of the type of failure and for any technical assistance that may be needed.
2. Switch off heat pump and start up again.
The heat pump starts up again autonomously when the cause of the failure has been lifted.
3. If the code is displayed again, correct the problem by following the instructions in the table below:

Code	Messages	Description	Checking / solution
B00	BL.PSU ERROR	The PSU PCB is incorrectly configured	Parameter error on the PSU PCB ▶ Set the type of generator again in the menu #CONFIGURATION (Refer to the original rating plate)
B02	BL.FLOW S.	The MIT flow sensor is short circuited or on an open circuit.	Bad connection. ▶ Check the wiring between the PCU PCB and the sensor. ▶ Check that the SU PCB is correctly in place. ▶ Check that the sensor has been correctly fitted. ▶ Check the sensor resistor. See:  "Sensor characteristics", page 16.
B08	BL.SC.IN.OPEN	The BL inlet on the PCU PCB terminal block is open. No antifreeze protection.	The contact connected to the BL inlet is open. ▶ Check the contact on the BL inlet.
			Parameter error. ▶ Check the parameter E. BL .
			Bad connection. ▶ Check the wiring.

Code	Messages	Description	Checking / solution
B09	BL.SC.IN.OPEN	The BL inlet on the PCU PCB terminal block is open. Antifreeze protection.	The contact connected to the BL inlet is open.
			▶ Check the contact on the BL inlet.
			Parameter error.
			▶ Check the parameter E. BL
			Bad connection.
			▶ Check the wiring.
B10	BL.GROUP.EXT.	Failure outside unit.	▶ Consult the error codes specific to the outdoor module.
B11	BL.COM SCU	Communication error with the SCU PCB.	Bad connection
			▶ Check the wiring
			PCB SCU not installed in the equipment
			▶ Install an SCU PCB
B12	BL.WATER MIS.	The water pressure is lower than 0,5 bar	Not enough water in the circuit. ▶ Top up the installation with water.
B13	BL.DHW. S.	The DHW tank sensor is disconnected or short circuited	▶ Check that the sensor is actually connected to the S.ECS inlet on the PCU
			▶ Check the wiring
			▶ Check the Ohmic value of the sensor. Replace it if necessary
			See:  "Sensor characteristics", page 16.
B14	BL.OUTSIDE.S	The outside temperature sensor is disconnected or short circuited.	▶ Check that the sensor is actually connected to the S.EXT inlet on the PCU
			▶ Check the wiring
			▶ Check the Ohmic value of the sensor. Replace it if necessary
			See:  "Sensor characteristics", page 16.
B17	BL.BAD PSU	The parameters saved on the PCU PCB are impaired.	Parameter error on the PCU PCB. ▶ Replace the PCU PCB.
B18	BL.BAD PSU	The PSU PCB is not recognised	Wrong PSU PCB for this heat pump.
			▶ Replace the PSU PCB.
B19	BL.NO CONFIG	The inside module has not been configured.	The PCU PCB has been changed. ▶ Set the type of generator again in the menu #CONFIGURATION (Refer to the original rating plate).
B39	BL.FLOW	Low flow rate.	▶ Check the settings of the heating pump on the heat pump.
			▶ Check that the filter is not blocked.
B40	BL.FLOW.STOP	Flow rate fault.	▶ Check the settings of the heating pump on the heat pump.
			▶ Check that the filter is not blocked.
B41	BL.COM.CPT.kWh	Communication error with the energy meter option PCB.	Bad connection
			▶ Check the wiring
B50	BL.S.DEP.CPT.kWh	Energy meter flow sensor error.	▶ Check the connection and resistance of the sensor
B51	BL.S.RET.CPT.kWh	Energy meter return sensor error.	▶ Check the connection and resistance of the sensor
B52	BL.CPT.kWh.ELEC1	Electical meter ELEC 1 error.	▶ Check that there is no short-circuit on input ELEC1
B53	BL.CPT.kWh.ELEC2	Electical meter ELEC 2 error.	▶ Check that there is no short-circuit on input ELEC2
B54	BL.CPT.kWh.THERM	Thermal meter error.	▶ Check that there is no short-circuit on input THERM
B55	BL.FLOW	Low flow rate.	▶ Check the settings of the heating pump on the heat pump.
			▶ Check that the filter is not blocked.

Code	Messages	Description	Checking / solution
M04	REVISION	A service is required.	The date programmed for the service has been reached. ▶ Service the heat pump. ▶ To clear the inspection, programme another date in the menu #REVISION or set the parameter REVISION TYPE to OFF.
	FL.DRY.B XX DAYS FL.DRY.C XX DAYS FL.DRY.B+C XX DAYS	Floor drying is active. XX DAYS = Number of days' floor drying remaining.	Floor drying is underway. Heating on the circuits not concerned is shut down. ▶ Wait for the number of days shown to change to 0. ▶ Set the parameter SCREED DRYING to OFF.
M23	CHANGE OUTSI.S	The outside temperature sensor is defective.	Change the outside radio temperature sensor.

8.3 Message history

The menu #MESSAGE HISTORIC is used to consult the last 10 messages displayed by the control panel.

1. Access the "After Sales" level: Hold down the  key until #PARAMETERS is displayed.
2. Select the menu #MESSAGE HISTORIC.



- ▶ Turn the rotary button to scroll through the menus or modify a value.
- ▶ Press the rotary button to access the selected menu or confirm a value modification.

 For a detailed explanation of menu browsing, refer to the chapter: "Browsing in the menus", page 80

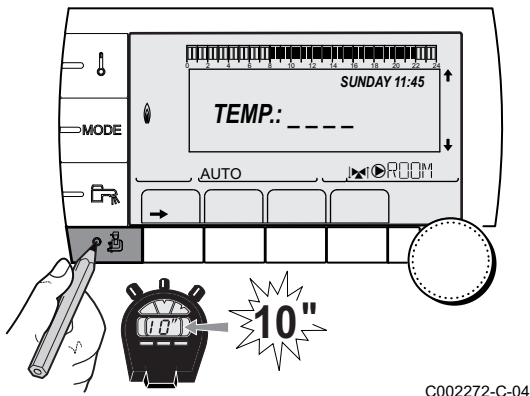

C002272-C-04

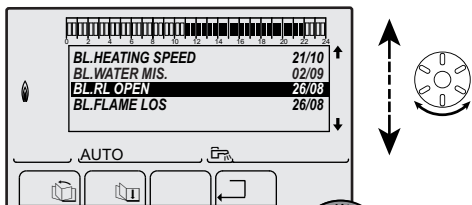

C002381-B-04

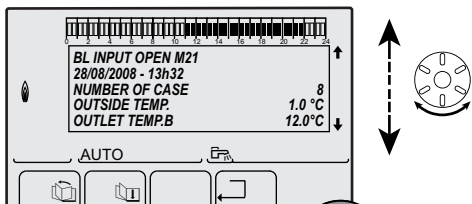

C002382-B-04

3. The list of the last 10 messages is displayed.

4. Select a message to consult the information pertaining to it.

8.4 Faults (Code type Lxx or Dxx)

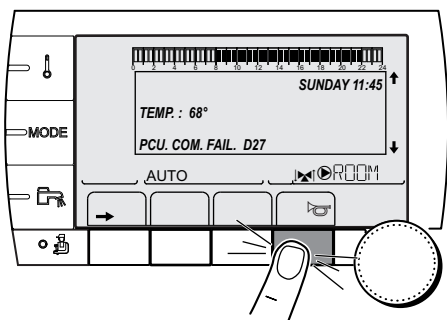



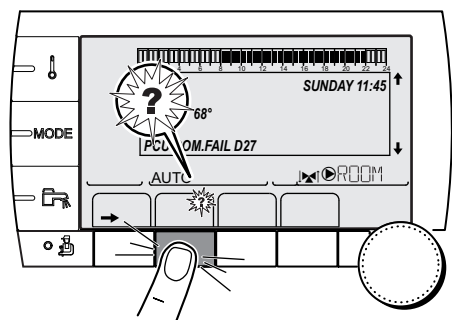



C002604-B-04









C002302-D-04

1. Make a note of the code displayed.
The code is important for the correct and rapid diagnosis of the type of failure and for any technical assistance that may be needed.
2. Press the  key. If the code is displayed again, switch off the boiler and then switch it back on.
3. Press the ? key. Follow the instructions displayed to solve the problem.
4. Consult the meaning of the codes in the table below:

Code	Faults	Cause of the fault	Description	Checking / solution
D03 D04	OUTL S.B FAIL. OUTL S.C FAIL.	SCU	Circuit B flow sensor fault Circuit C flow sensor fault Remarks: The circuit pump is running. The 3-way valve motor on the circuit is no longer powered and can be adjusted manually.	Bad connection <ul style="list-style-type: none"> ▶ Check whether the sensor is connected:  See chapter: "Deletion of sensors from the memory in the PCB", page 124 ▶ Check the link and the connectors ▶ Check that the sensor has been correctly fitted Sensor fault <ul style="list-style-type: none"> ▶ Check the Ohmic value of the sensor ▶ Replace the sensor if necessary
D05	OUTSI.S.FAIL.	SCU	Outside temperature sensor fault Remarks: The set point is equal to the MAX MIT parameter. The valve setting is no longer ensured but monitoring the maximum temperature of the circuit after the valve is ensured. Valves may be manually operated. Reheating the domestic hot water remains ensured.	Bad connection <ul style="list-style-type: none"> ▶ Check whether the sensor is connected:  See chapter: "Deletion of sensors from the memory in the PCB", page 124 ▶ Check the link and the connectors ▶ Check that the sensor has been correctly fitted Sensor fault <ul style="list-style-type: none"> ▶ Check the Ohmic value of the sensor ▶ Replace the sensor if necessary

Code	Faults	Cause of the fault	Description	Checking / solution
D07	SYST.SENS.FAIL.	SCU	System sensor fault	<p>Bad connection</p> <ul style="list-style-type: none"> ▶ Check whether the sensor is connected:  See chapter: "Deletion of sensors from the memory in the PCB", page 124 ▶ Check the link and the connectors ▶ Check that the sensor has been correctly fitted <p>Sensor fault</p> <ul style="list-style-type: none"> ▶ Check the Ohmic value of the sensor ▶ Replace the sensor if necessary
D09	DHW S.FAILURE	SCU	Domestic hot water sensor fault Remarks: Heating of domestic hot water is no longer ensured. The load pump operates. The tank load temperature is equal to the temperature of the inside module.	<p>Bad connection</p> <ul style="list-style-type: none"> ▶ Check whether the sensor is connected:  See chapter: "Deletion of sensors from the memory in the PCB", page 124 ▶ Check the link and the connectors ▶ Check that the sensor has been correctly fitted <p>Sensor fault</p> <ul style="list-style-type: none"> ▶ Check the Ohmic value of the sensor ▶ Replace the sensor if necessary
D11 D12 D13	ROOM S.A FAIL. ROOM S.B FAIL. ROOM S.C FAIL.	SCU	A room temperature sensor fault B room temperature sensor fault C room temperature sensor fault Note: The circuit concerned operates without any influence from the room sensor.	<p>Bad connection</p> <ul style="list-style-type: none"> ▶ Check whether the sensor is connected:  See chapter: "Deletion of sensors from the memory in the PCB", page 124 ▶ Check the link and the connectors ▶ Check that the sensor has been correctly fitted <p>Sensor fault</p> <ul style="list-style-type: none"> ▶ Check the Ohmic value of the sensor ▶ Replace the sensor if necessary
D14	MC COM.FAIL	SCU	Break in communication between the SCU PCB and the radio module	<p>Bad connection</p> <ul style="list-style-type: none"> ▶ Check the link and the connectors <p>Boiler module failure</p> <ul style="list-style-type: none"> ▶ Change the boiler module
D15	ST.TANK S.FAIL	SCU	Storage tank sensor fault Note: The hot water storage tank reheating operation is no longer assured.	<p>Bad connection</p> <ul style="list-style-type: none"> ▶ Check whether the sensor is connected:  See chapter: "Deletion of sensors from the memory in the PCB", page 124 ▶ Check the link and the connectors ▶ Check that the sensor has been correctly fitted <p>Sensor fault</p> <ul style="list-style-type: none"> ▶ Check the Ohmic value of the sensor ▶ Replace the sensor if necessary

Code	Faults	Cause of the fault	Description	Checking / solution
D16 D16	SWIM.B S.FAIL SWIM.C S.FAIL	SCU	Swimming pool sensor fault circuit B Swimming pool sensor fault circuit C Note: Swimming pool reheating is always done during the circuit's comfort period.	<p>Bad connection</p> <ul style="list-style-type: none"> ▶ Check whether the sensor is connected:  See chapter: "Deletion of sensors from the memory in the PCB", page 124 ▶ Check the link and the connectors ▶ Check that the sensor has been correctly fitted <p>Sensor fault</p> <ul style="list-style-type: none"> ▶ Check the Ohmic value of the sensor ▶ Replace the sensor if necessary
D17	DHW 2 S.FAIL	SCU	Sensor fault tank 2	<p>Bad connection</p> <ul style="list-style-type: none"> ▶ Check whether the sensor is connected:  See chapter: "Deletion of sensors from the memory in the PCB", page 124 ▶ Check the link and the connectors ▶ Check that the sensor has been correctly fitted <p>Sensor fault</p> <ul style="list-style-type: none"> ▶ Check the Ohmic value of the sensor ▶ Replace the sensor if necessary
D18	ST.TANK S.FAIL	SCU	Solar tank sensor fault	<p>Bad connection</p> <ul style="list-style-type: none"> ▶ Check whether the sensor is connected:  See chapter: "Deletion of sensors from the memory in the PCB", page 124 ▶ Check the link and the connectors ▶ Check that the sensor has been correctly fitted <p>Sensor fault</p> <ul style="list-style-type: none"> ▶ Check the Ohmic value of the sensor ▶ Replace the sensor if necessary
D19	SOL.COL.S.FAIL	SCU	Header sensor fault	<p>Bad connection</p> <ul style="list-style-type: none"> ▶ Check whether the sensor is connected:  See chapter: "Deletion of sensors from the memory in the PCB", page 124 ▶ Check the link and the connectors ▶ Check that the sensor has been correctly fitted <p>Sensor fault</p> <ul style="list-style-type: none"> ▶ Check the Ohmic value of the sensor ▶ Replace the sensor if necessary
D20	SOL COM.FAIL	SCU	<ul style="list-style-type: none"> ▶ Switch off heat pump and start up again ▶ Check whether the solar module is switched on. If necessary, replace the fuse  Refer to the installation, commissioning and service manual for the DHW tank ▶ Check the connection between the SCU-C and the solar module 	

Code	Faults	Cause of the fault	Description	Checking / solution
D27	PCU COM. FAIL	SCU	Communication failure between the SCU and PCU PCBs	<ul style="list-style-type: none"> ▶ Check the wiring between the SCU and PCU PCBs ▶ Check that the PCU PCB is powered up (green LED on or flashing) ▶ Change the PCU PCB
D32	5 RESET:ON/OFF	SCU	5 resets done in less than an hour	<ul style="list-style-type: none"> ▶ Switch off heat pump and start up again
D37	TA-S SHORT-CIR	SCU	The Titan Active System® is short-circuited	<ul style="list-style-type: none"> ▶ Check that the connection cable between the SCU PCB and the anode is not short-circuited ▶ Check that the anode is not short-circuited <p>Remarks: Domestic hot water production has stopped but can nonetheless be restarted using key .</p> <p>The tank is no longer protected. If a tank without Titan Active System® is connected to the heat pump, check that the TAS simulation connector (delivered in package AD212) is fitted to the sensor board.</p>
D38	TA-S DISCONN	SCU	The Titan Active System® is on an open circuit	<ul style="list-style-type: none"> ▶ Check that the connection cable between the SCU PCB and the anode is not severed ▶ Check that the anode is not broken <p>Remarks: Domestic hot water production has stopped but can nonetheless be restarted using key .</p> <p>The tank is no longer protected. If a tank without Titan Active System® is connected to the heat pump, check that the TAS simulation connector (delivered in package AD212) is fitted to the sensor board.</p>
D99	DEF.BAD PCU		The SCU software version does not recognise the PCU connected	<ul style="list-style-type: none"> ▶ Update the SCU with the appropriate software version.
L33	FAIL.FLOW		The flow rate is lower than the threshold defined by the MIN.STOP.FLOW. parameter	<ul style="list-style-type: none"> ▶ Check that the valve is open and the filter is not clogged. ▶ Check the speed setting on the circulator pump in the heat pump and the electrical connection.

8.4.1. Deletion of sensors from the memory in the PCB

The configuration of the sensors is memorised by the SCU PCB. If a sensor fault appears whilst the corresponding sensor is not connected or has been voluntarily removed, please delete the sensor from the SCU PCB memory.

- ▶ Press key **?** repeatedly until **Do you want to delete this sensor?** is displayed.
- ▶ Select **YES** by turning the rotary button and press to confirm.





The outside temperature sensor cannot be deleted.

8.5 Failure history

The menu **#DEFAULT HISTORIC** is used to consult the last 10 faults displayed by the control panel.

1. Access the "After Sales" level: Hold down the  key until **#PARAMETERS** is displayed.
2. Select the menu **#DEFAULT HISTORIC**.

-  Turn the rotary button to scroll through the menus or modify a value.
-  Press the rotary button to access the selected menu or confirm a value modification.

 For a detailed explanation of menu browsing, refer to the chapter: "Browsing in the menus", page 80

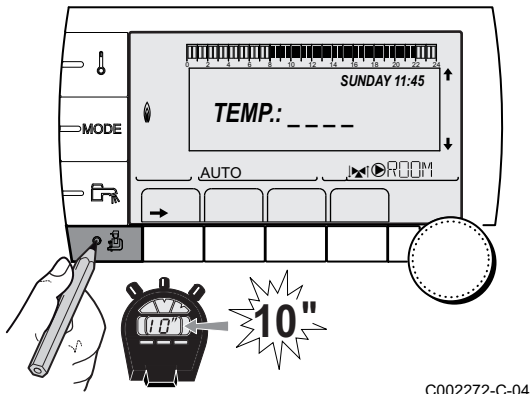

3. The list of the last 10 faults is displayed.

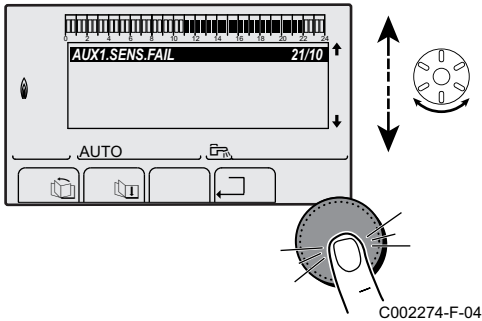

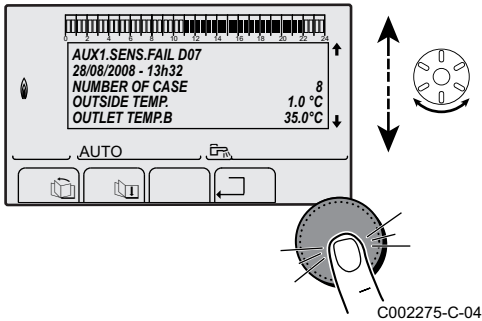

4. Select a fault to consult the information pertaining to it.



8.6 Parameter and input/output check (mode tests)

Use the following menus to target the cause of a malfunction.

1. Access the "After Sales" level: Hold down the  key until **#PARAMETERS** is displayed.
2. Check the following parameters:

-  Turn the rotary button to scroll through the menus or modify a value.
-  Press the rotary button to access the selected menu or confirm a value modification.

 For a detailed explanation of menu browsing, refer to the chapter: "Browsing in the menus", page 80

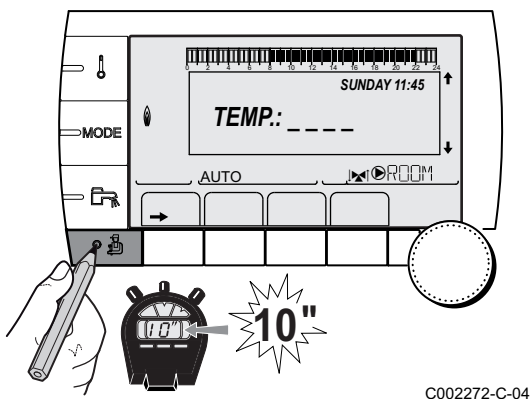

After Sales level - Menu #PARAMETERS	
Parameter	Description
PERMUT ⁽¹⁾	Master generator active
STAGE ⁽¹⁾	Number of generators requiring heating
NB.CASC. ⁽¹⁾	Number of generators recognised in the cascade
NB. VM: ⁽¹⁾	Number of DIEMATIC VM control systems recognised in the cascade
OUTPUT SOL P. ⁽²⁾	Solar pump command
MEAN OUTSIDE T ⁽²⁾	Average outside temperature
CALC T SYST ⁽¹⁾	System flow temperature calculated by the control system
CALC.T.MIT	Calculated temperature of the MIT
TEMP.SYSTEM ^{(3) (2)}	Temperature of the system flow water if multi-generator
TEMP MIT MEAN	Average MIT temperature
MIT TEMP.	Instantaneous MIT temperature
CALCULATED T.A	Calculated temperature for circuit A
CALCULATED T. B ⁽²⁾	Calculated temperature for circuit B
CALCULATED T. C ⁽²⁾	Calculated temperature for circuit C
DHW SETP.CORRECT ⁽²⁾	DHW set point used by the boiler bearing solar back-up in mind
OUTLET TEMP.B ^{(3) (2)}	Temperature of the flow water in circuit B
SWIMMING P.T.B	Temperature of the swimming pool water sensor on circuit B
OUTLET TEMP.C ^{(3) (2)}	Temperature of the flow water in circuit C
SWIMMING P.T.C	Temperature of the swimming pool water sensor on circuit C
OUTSIDE TEMP. ⁽³⁾	Outside temperature
MEDIUM COP	Coefficient of performance calculated by the inside module
THRESHOLD COP	Coefficient of performance as of which heat pump running is enabled
ROOMTEMP.A ⁽³⁾	Room temperature of circuit A
ROOMTEMP.B ^{(3) (2)}	Room temperature of circuit B
ROOMTEMP.C ^{(3) (2)}	Room temperature of circuit C
DHW TEMP. ^{(3) (2)}	Water temperature in the DHW tank
IN 0-10V ^{(3) (2)}	Voltage at input 0-10 V
PRESSURE ⁽³⁾	Water pressure in the installation
STOR.TANK.TEMP ^{(3) (2)}	Water temperature in the storage tank
T.DHW BOTTOM ^{(3) (2)}	Water temperature in the bottom of the DHW tank
DHW A TEMP. ^{(3) (2)}	Water temperature in the second DHW tank connected to circuit A
TEMP.TANK AUX ^{(3) (2)}	Water temperature in the second DHW tank connected to the AUX circuit
KNOB A	Position of temperature setting button on room sensor A
KNOB B ⁽²⁾	Position of temperature setting button on room sensor B
KNOB C ⁽²⁾	Position of temperature setting button on room sensor C
OFFSET ADAP A	Parallel trigger calculated for circuit A
OFFSET ADAP B ⁽²⁾	Parallel trigger calculated for circuit B
OFFSET ADAP C ⁽²⁾	Parallel trigger calculated for circuit C
(1) The parameter is only displayed if CASCADE is set to ON	
(2) The parameter is only displayed for the options, circuits or sensors actually connected	
(3) The parameter can be displayed by pressing key μ .	

After Sales level - Menu #TEST OUTPUTS		
Parameter	Adjustment range	Description
P.CIRC.A	ON / NO	Stop/start pump circuit A
P.CIRC.B ⁽¹⁾	ON / NO	Stop/start pump circuit B
P.CIRC.C ⁽¹⁾	ON / NO	Stop/start pump circuit C
SOLAR P. ⁽¹⁾	ON / NO	Solar pump On/Off
AUX.CIRC.	ON / NO	On/Off auxiliary outlet
HW.PUMP ⁽¹⁾	ON / NO	Stop/start domestic hot water pump
3WV B ⁽¹⁾	REST	No command
	OPEN:	Opening 3-way valve circuit B
	CLOSE:	Closure 3-way valve circuit B
3WV C ⁽¹⁾	REST	No command
	OPEN:	Opening 3-way valve circuit C
	CLOSE:	Closure 3-way valve circuit C
TEL.OUTPUT	ON / NO	On/Off telephone relay outlet
PUMP HP	ON / NO	HP pump ON/OFF
PUMP MIT/MHR	ON / NO	ON/OFF MIT pump
STAGE 1	ON / NO	ON/OFF back-up stage 1
STAGE 2	ON / NO	ON/OFF back-up stage 2
DHW BACKUP	ON / NO	ON/OFF DHW back-up
RV	ON / NO	Reversal valve command on the PCU PCB
(1) The parameter is only displayed for the options, circuits or sensors actually connected		

After Sales level - Menu #TEST INPUTS		
Parameter	Status	Description
PHONE REM.		Bridge on telephone input (1 = presence, 0 = absence)
FAILURE	ON	Fault display
	OFF	No fault
SEQUENCE		Control system sequence
TYPE		Type of heat pump
P HP	STOP / GO	Status of the PAC pump
R.CTRL A ⁽¹⁾	ON	Presence of a remote control A
	OFF	No remote control A
R.CTRL B ⁽¹⁾	ON	Presence of a remote control B
	OFF	No remote control B
R.CTRL C ⁽¹⁾	ON	Presence of a remote control C
	OFF	No remote control C
(1) The parameter is only displayed for the options, circuits or sensors actually connected		

After Sales level - Menu #CONFIGURATION		
Parameter	Adjustment range	Description
MODE:	MONO/ ALL.CIRC	To chose if the exemption made for one remote control applies to a single circuit (MONO) or if it must be transmitted to a group of circuits (ALL.CIRC)
TYPE		Generator type (HP)
DFDU ⁽¹⁾		Generator type
AUTODETECTION		Detection of SCU boards connected to the PCU board
TAS	OFF/ON	Activation of the Titan Active System® function
(1) The parameter is only displayed if INSTALLATION is set to EXTENDED		

After Sales level - Menu #INFORMATION	
Parameter	Description
S/N SCU	Serial number of the SCU board
CTRL	Software control number
VER.ROM PCU	Version of the PCU PCB programme
VERS.PARAM PCU	Version of the PCU PCB parameters
MC.VERSION ⁽¹⁾	Version of the boiler radio module programme
NUMBER REMOT A ⁽¹⁾	Information
NUMBER REMOT B ⁽¹⁾	Information
NUMBER REMOT C ⁽¹⁾	Information
VERS.SUN ⁽¹⁾	Solar control system software version
CALIBRA.CLOCK	Clock calibration

(1) The parameter is only displayed for the options, circuits or sensors actually connected

After Sales level - Menu #METERS	
Parameter	Description
NB IMPULS.COMP	Number of heat pump start-ups
RUNTIME HP	Number of hours' operation of compressor
FCT.HYDRO	Number of hours operation of the hydraulic backup
NB IMPULS.HYDRO	Number of start-ups of the hydraulic backup
FCT. STAGE 1	Number of hours' back-up operation stage 1
NB IMP.STAGE 1	Number of back-up starts stage 1
FCT.STAGE 2	Number of hours' back-up operation stage 2
NB IMP.STAGE 2	Number of back-up starts stage 2
FCT. APP.DHW	Number of hours' operation of the back-ups
ELEC.ENERGY HEAT ⁽¹⁾	Consumption of electrical energy in heating mode
ELEC.EN.DHW ⁽¹⁾	Consumption of electrical energy in DHW mode
ELEC.ENERGY COOL ⁽¹⁾	Consumption of electrical energy in cooling mode
ELEC.ENERGY ⁽¹⁾	Total electrical energy consumed
ELEC.ENERG.Y1 ⁽¹⁾	Total electrical energy consumed in the previous year
ELEC.ENERG.Y2 ⁽¹⁾	Total electrical energy consumed two years ago
THERM.ENERG.HEAT ⁽¹⁾	Thermal energy generated in heating mode
THERM.ENERG.DHW ⁽¹⁾	Thermal energy generated in DHW mode
THERM.ENERG.COOL ⁽¹⁾	Thermal energy generated in cooling mode
THERM.ENERGY ⁽¹⁾	Total thermal energy yield
THERM.ENERG.Y1 ⁽¹⁾	Total thermal energy yield in the previous year
THERM.ENERG.Y2 ⁽¹⁾	Total thermal energy yield two years ago
PERF.FACTOR ⁽¹⁾	Seasonal coefficient of performance
PERF.FACTOR A1 ⁽¹⁾	Seasonal coefficient of performance the previous year

(1) The parameter is only displayed if the corresponding option is connected

Control system sequence						
Status		Sub-status		Heating	Domestic hot water	Remarks
0	Stop					Total shutdown
		0	Stop	x	x	
		10	Time delay on reversibility	x		

Control system sequence						
Status		Sub-status	Heating	Domestic hot water	Remarks	
1	Demand (Heating / Cooling / Domestic hot water)				Only when the heat pump or boiler heating pump is running owing to post-operation	
		1	Anti-hunting	x		Only in heating/cooling mode when there is no demand for domestic hot water
		2	Pending start-up conditions	x	x	Demand present with back-up and heat pump off
		3	Heat pump and back-up power cut off active	x	x	
3	Operating in heating mode				The heat pump or one of the back-ups at least is running	
		30	Normal operation	x		
		31	Heat pump off as the temperature is too high	x		
		32	Normal operation, Back-up stopped owing to the bivalency point	x		
		33	Normal running with the set point temperature equal to the minimum flow temperature to guarantee defrosting	x		
		34	Heat pump off owing to the power cut off	x		
		35	Back-up off owing to the power cut off	x		
		36	Heat pump off as the outside temperature is too low	x		
		37	Heat pump off owing to a defrosting error and a flow temperature value of less than 18°C	x		
		38	Defrosting	x		
39	Defrosting with flow temperature less than the minimum threshold permitted	x				
4	Operating in DHW mode				The heat pump or one of the back-ups at least is running (Except domestic hot water back-up)	
		30	Normal operation		x	
		31	Heat pump off as the temperature is too high		x	
		34	Heat pump off owing to the power cut off		x	
		35	Back-up off owing to the power cut off		x	
		36	Heat pump off as the outside temperature is too low		x	
38	Defrosting		x			
5	Heat pump shutdown					
		40	Heating pump on the heat pump in post-operation	x	x	No heating or domestic hot water demand

Control system sequence					
Status	Sub-status	Heating	Domestic hot water	Remarks	
6	Inside module shutdown				
	60	Inside module heating pump in post-operation	x	x	No heating or domestic hot water demand
7	Operation in cooling mode				
		30	Normal operation	x	
		34	Heat pump off owing to the power cut off	x	
11	Sweeping mode (Heating)				
		30	Normal operation		
		31	Heat pump off as the temperature is too high		
		32	Normal operation, Back-up stopped owing to the bivalency point		
		33	Normal running with the set point temperature equal to the minimum flow temperature to guarantee defrosting		
		34	Heat pump off owing to the power cut off		
		35	Back-up off owing to the power cut off		
		36	Heat pump off as the outside temperature is too low		
		37	Heat pump off owing to a defrosting error and a flow temperature value of less than 18°C		
		38	Defrosting		
12	Sweeping mode (Cooling)				
		30	Normal operation	x	
		34	Heat pump off owing to the power cut off	x	
17	Bleed				
		61	Reversal valve in domestic hot water position		
		62	Closure of the heating pump relays on the inside and outside modules		
		63	Reversal valve in heating position		
		64	Opening of the heating pump relays on the inside and outside modules		

9 Spare parts

9.1 General

When it is observed subsequent to inspection or maintenance work that a component in the appliance needs to be replaced, use only original spare parts or recommended spare parts and equipment.



To order a spare part, give the reference number shown on the list.

9.2 Spare parts

9.2.1. Outdoor unit 4 and 6 kW

■ Structure part

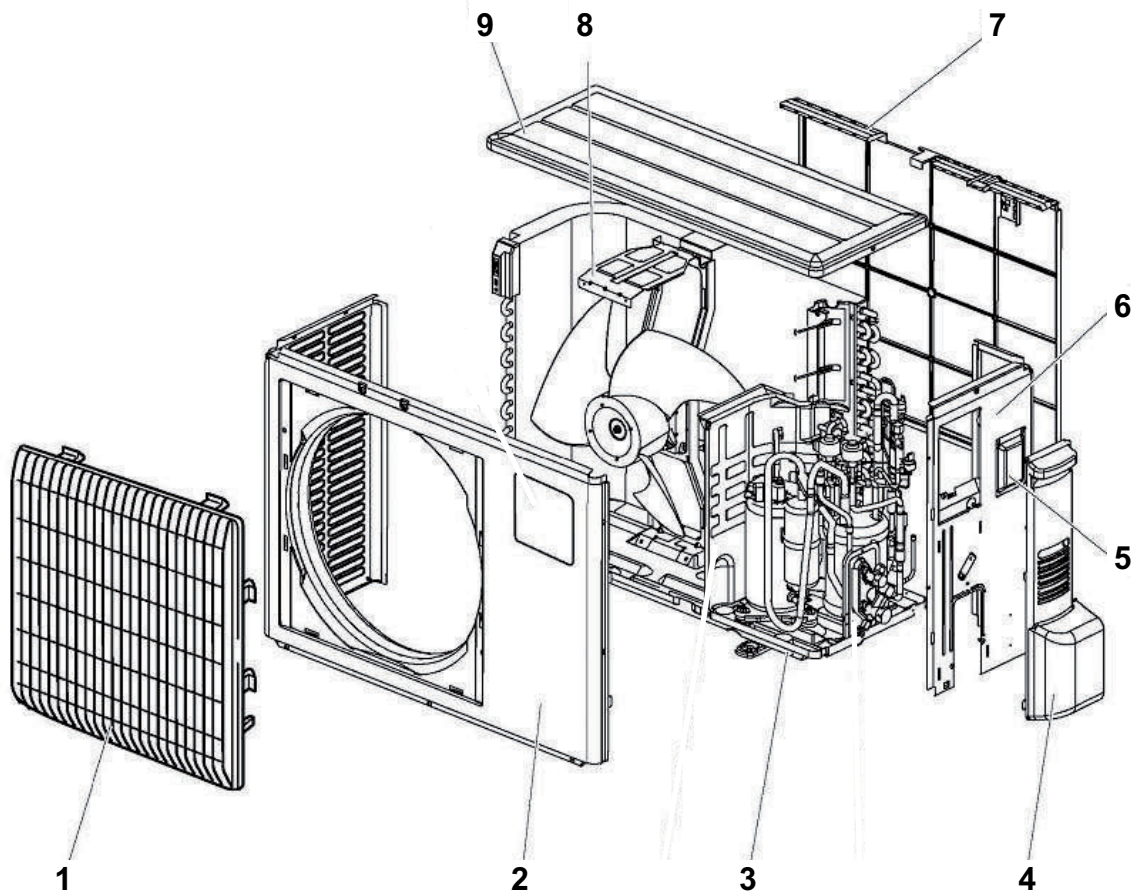

MW-2000059-1

Markers	Reference	Description
1	300023680	Grill
2	7604144	Front panel
3	7604156	Base frame
4	300023684	Maintenance access panel
5	7604143	Inspection hatch
6	7604160	Side panel, right
7	300023688	Protective grid
8	7604145	Fan motor bracket
9	7604151	Top panel

■ Electrical part

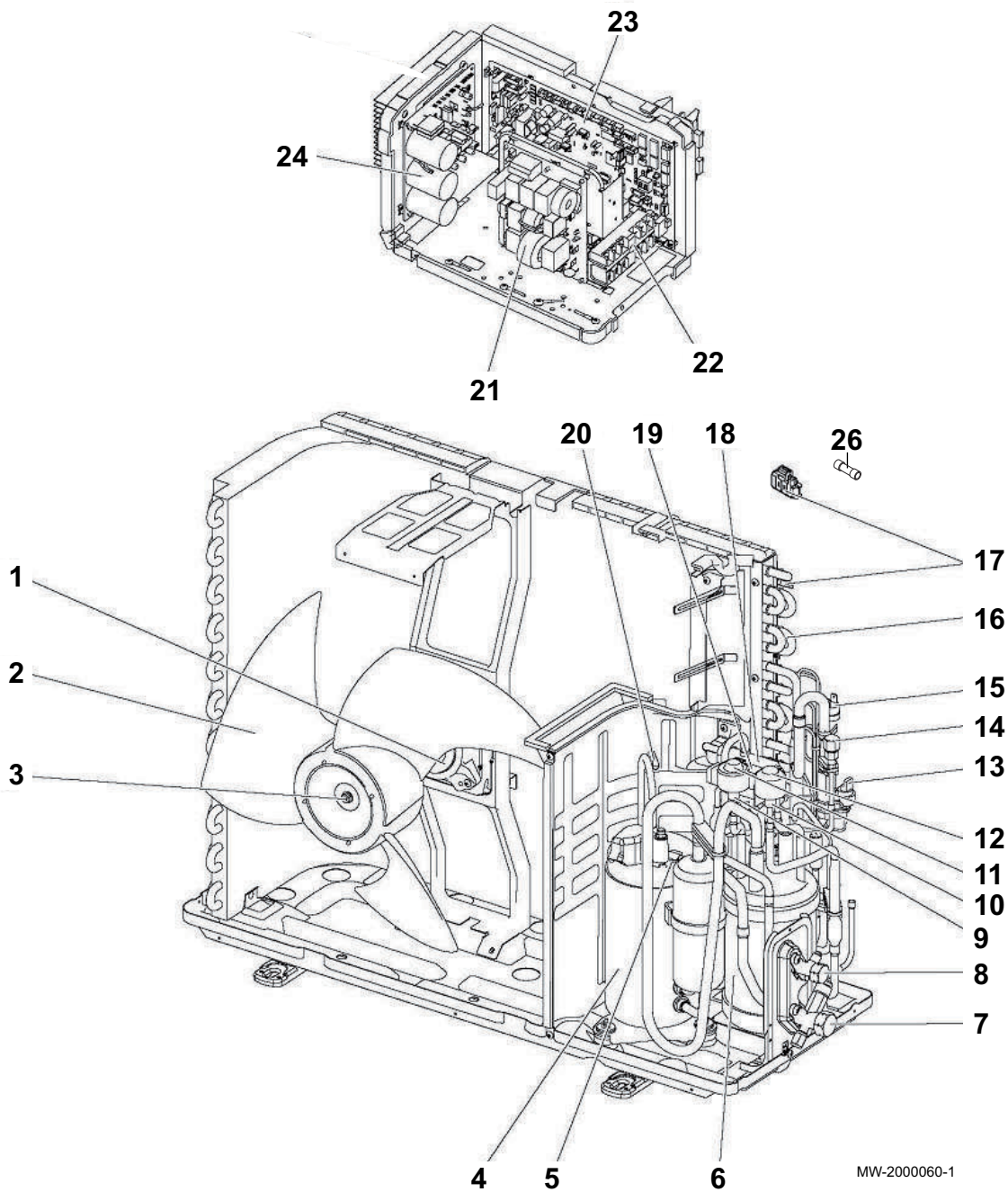

MW-2000060-1

Markers	Reference	Description
1	300023644	Fan motor
2	300023645	Fan rotor
3	7604150	Rotor holding nut
4	7604154	Compressor SNB130FGCM2
5	7604142	Compressor sensor
6	7604152	Power receiver
7	7604157	1/2" stop valve
8	7604139	1/4" stop valve
9	7604141	Expansion valve

Markers	Reference	Description
10	7604158	Expansion valve
11	7604159	Expansion valve coil
12	7604161	Expansion valve coil
13	7604140	High pressure sensor
14	300018094	Load plug
15	300018123	HP pressure switch 41,5 bar
16	7604149	Condensation / absorption battery
17	300023670	Outside temperature sensor battery TH
18	300023668	4-way valve
19	300023666	Solenoid valve coil
20	300023671	Compressor discharge temperature sensor TH4
21	300023674	Electronic filter board
22	300023673	Terminal block
23	7604155	Central unit PCB
24	7604146	Output board
25	300023672	Coil
26	7604148	Fuses 6,3A-250V
27	300018211	Sensor
28	300023665	Sensor battery inlet

9.2.2. Outdoor unit 8 kW

■ Structure part

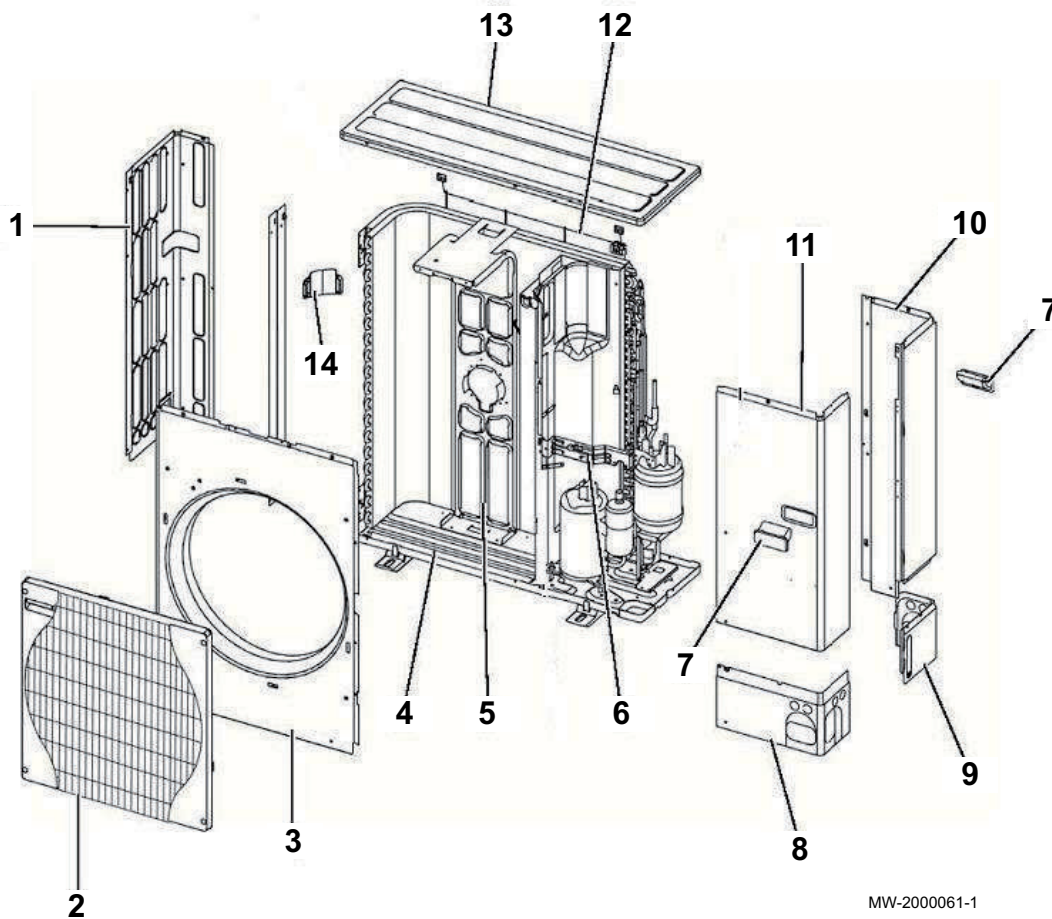

Markers	Reference	Description
1	7614219	Side panel, left
2	7614220	Protective grid
3	7614221	Front panel
4	7614222	Base frame
5	7614223	Fan motor bracket
6	7614224	Valve support
7	7614225	Door handle
8	7614226	Lower front panel
9	7614227	Lower back panel
10	7614228	Side panel, right
11	7614230	Maintenance access panel
12	7614231	Back protection grille
13	7614232	Top panel
14	7614233	Door handle

■ Electrical part

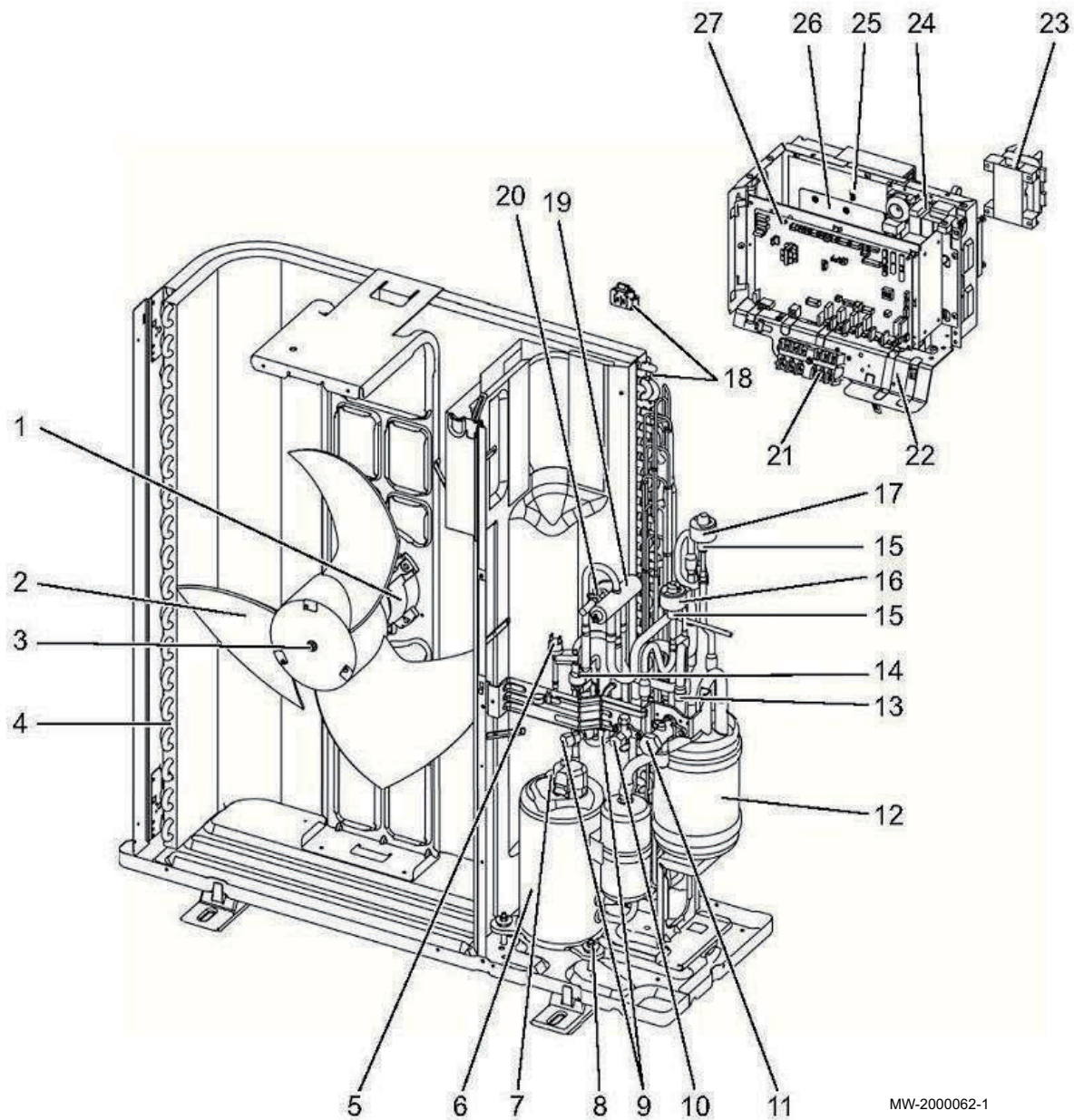

MW-2000062-1

Markers	Reference	Description
1	7614234	Fan motor
2	7614236	Fan rotor
3	7614237	Rotor holding nut
4	7614238	Condensation / absorption battery
5	7614239	HP pressure switch 41.5 bar
6	7614240	Compressor TNB220FLHMT
7	7614241	Compressor discharge temperature sensor
8	7614242	anti-vibration mountings
9	7614243	Load plug
10	7614244	3/8" stop valve
11	7614245	3/8" stop valve
12	7614246	Power receiver

Markers	Reference	Description
13	7614247	Filter
14	7614248	High pressure sensor
15	7614250	Expansion valve
16	7614251	Solenoid valve coil
17	7614252	Solenoid valve coil
18	7614253	Sensor battery inlet TH6/7
19	7614254	4-way valve
20	7614255	Coil
21	7614278	Terminal block
22	7614279	Control panel
23	7614280	Coil
24	7614282	EMI-supressor filter
25	7614283	Disspator sensor TH8
26	7614284	Output board
27	7614285	Central unit PCB
	7614286	Hot gas sensor
	7614288	Liquid sensor TH3

9.2.3. Outdoor unit 11 and 16 kW

■ Structure part

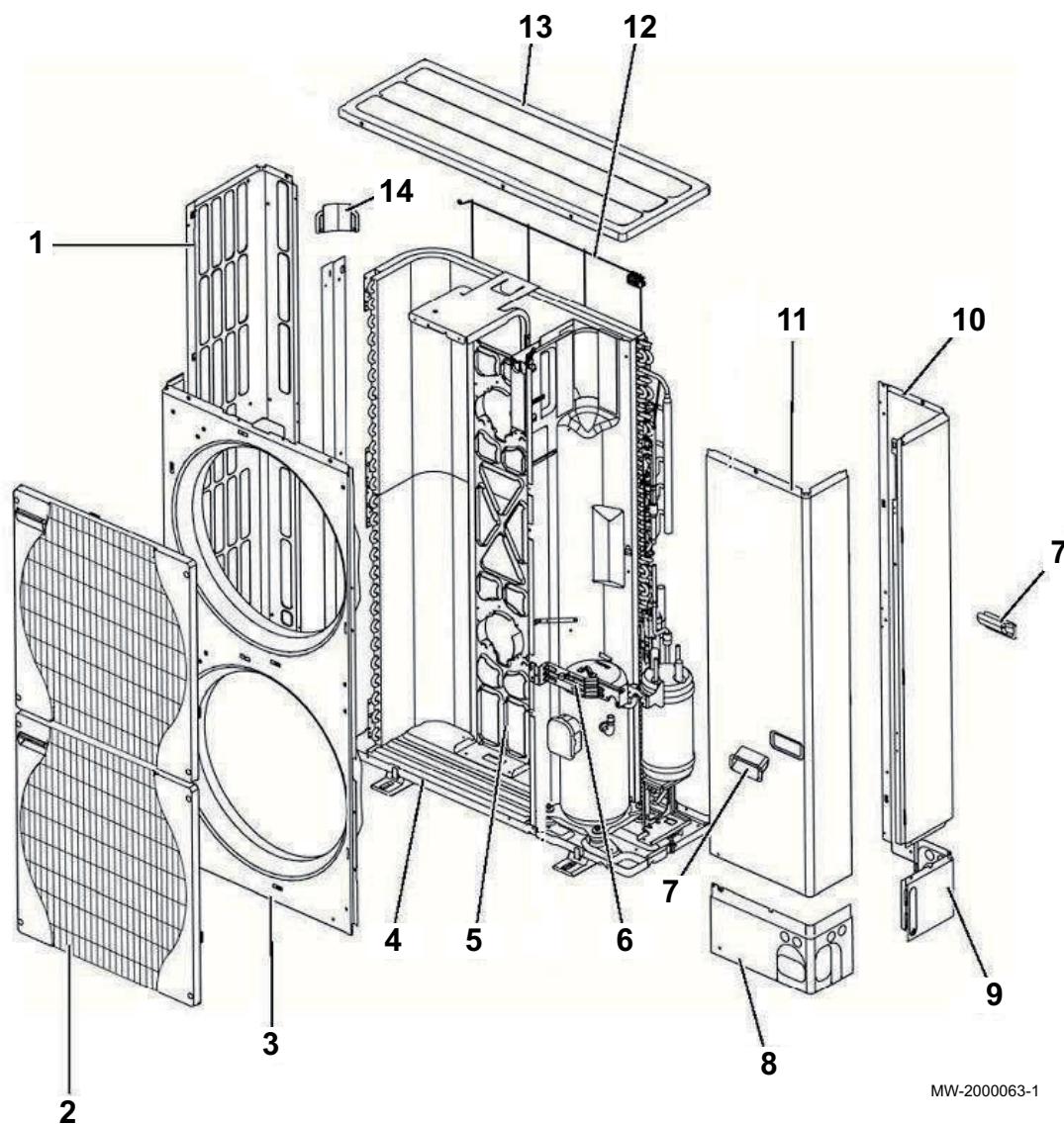

MW-2000063-1

Markers	Reference	Description
1	7614289	Side panel, left
2	7614220	Protective grid
3	7614290	Front panel
4	7614292	Base frame
5	7614293	Fan motor bracket
6	7614224	Valve support
7	7614225	Door handle
8	7614226	Lower front panel
9	7614227	Lower back panel
10	7614294	Side panel, right

Markers	Reference	Description
11	7614295	Maintenance access panel
12	7614296	Back protection grille
13	7614232	Top panel
14	7614233	Door handle

■ Electrical part MR-2

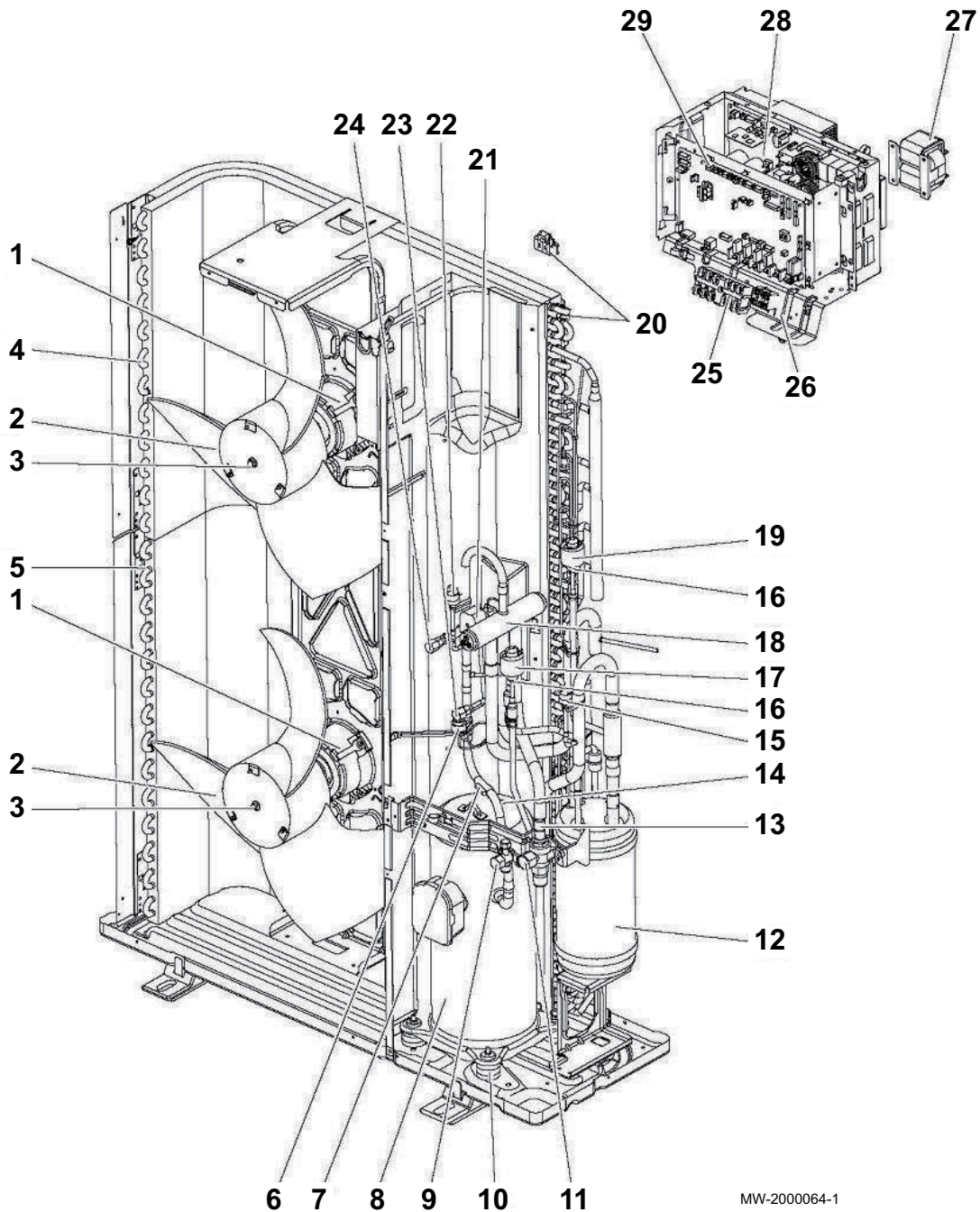

MW-2000064-1

Markers	Reference	Description
1	7614234	Fan motor
2	7614236	Fan rotor
3	7614237	Rotor holding nut
4	7614297	Top condensation / absorption battery
5	7614298	Bottom condensation / absorption battery
6	7614248	High pressure sensor
7	7614299	Hot gas sensor
8	7614300	Compressor ANB33FNEMT 11MR-2
8	7614301	Compressor ANB42FNEMT 16MR-2
9	7614244	3/8" stop valve
10	7614302	anti-vibration mountings
11	7614304	5/8" stop valve
12	7614305	Power receiver
13	7614247	Filter
14	7614306	Sensor
15	7614307	LP pressure switch
16	7614308	Expansion valve
17	7614251	Solenoid valve coil
18	7614309	4-way valve
19	7614252	Solenoid valve coil
20	7614253	Outside temperature sensor battery
21	7614310	Coil
22	7614239	HP pressure switch
23	7614243	Load plug
24	7614312	Load plug
25	7614278	Terminal block
26	7614313	Control panel 11MR-2
26	7614314	Control panel 16MR-2
27	7614280	Coil
28	7614284	Output board
29	7614285	Central unit PCB
	7614321	Liquid sensor TH3
	7614322	Condenser

■ Electrical part TR-2

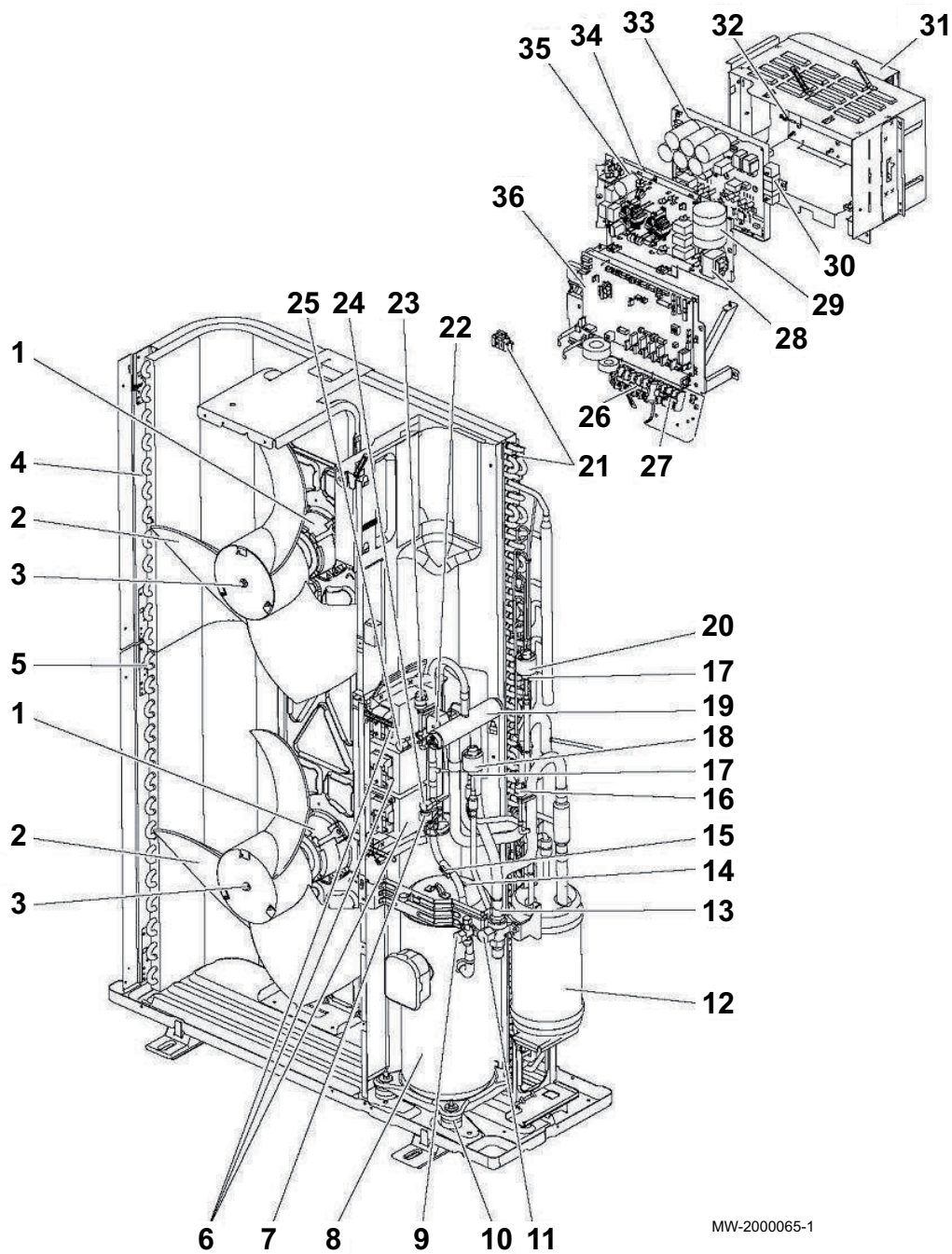

MW-2000065-1

Markers	Reference	Description
1	7614234	Fan motor
2	7614236	Fan rotor
3	7614237	Rotor holding nut
4	7614297	Top condensation / absorption battery
5	7614298	Bottom condensation / absorption battery
6	7614323	Coil
7	7614248	High pressure sensor
8	7614330	Compressor ANB33FNEMT 11TR-2
8	7614332	Compressor ANB42FNEMT 16TR-2

Markers	Reference	Description
9	7614244	3/8" stop valve
10	7614302	anti-vibration mountings
11	7614304	5/8" stop valve
12	7614305	Power receiver
13	7614247	Filter
14	7614333	Compressor discharge temperature sensor
15	7614286	Hot gas sensor
16	7614307	LP pressure switch
17	7614308	Expansion valve
18	7614251	Solenoid valve coil
19	7614309	4-way valve
20	7614252	Solenoid valve coil
21	7614335	Outside temperature sensor battery
22	7614255	Coil
23	7614239	HP pressure switch
24	7614243	Load plug
25	7614312	Load plug
26	7614337	Terminal block L
27	7614338	Terminal block S
28	7614339	Coil
29	7614340	Condenser
30	7614342	Resistance
31	7614343	Control panel 11TR-2
31	7614343	Control panel 16TR-2
32	7614346	Disspator sensor
33	7614247	Output board
34	7614348	Converter board
35	7614349	Electronic filter board
36	7614285	Central unit PCB
	7614350	Liquid sensor TH3

9.2.4. Outdoor unit 22 and 27 kW

■ Structure part

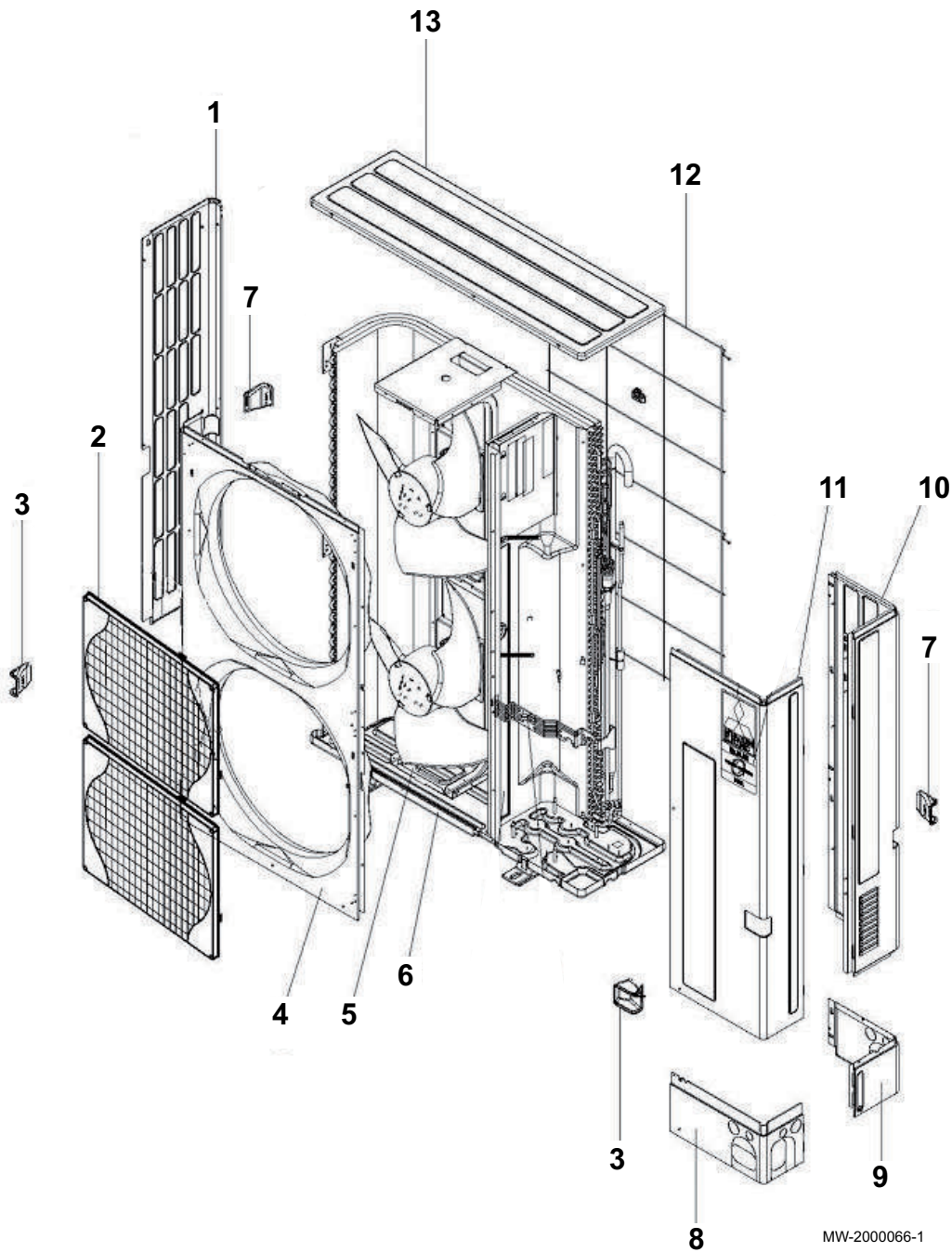

MW-2000066-1

Markers	Reference	Description
1	300027054	Side panel, left
2	300027055	Protective grid
3	300027056	Door handle
4	300027057	Front panel
5	300027058	Fan motor bracket

Markers	Reference	Description
6	300027059	Base frame
7	300027060	Door handle
8	300027062	Lower front panel 22TR
8	300027061	Lower front panel 27TR
9	300027063	Lower back panel 22TR
9	300027064	Lower back panel 27TR
10	300027065	Side panel, right
11	300027066	Maintenance access panel
12	300027067	Back protection grille
13	300027068	Top panel

■ Electrical part

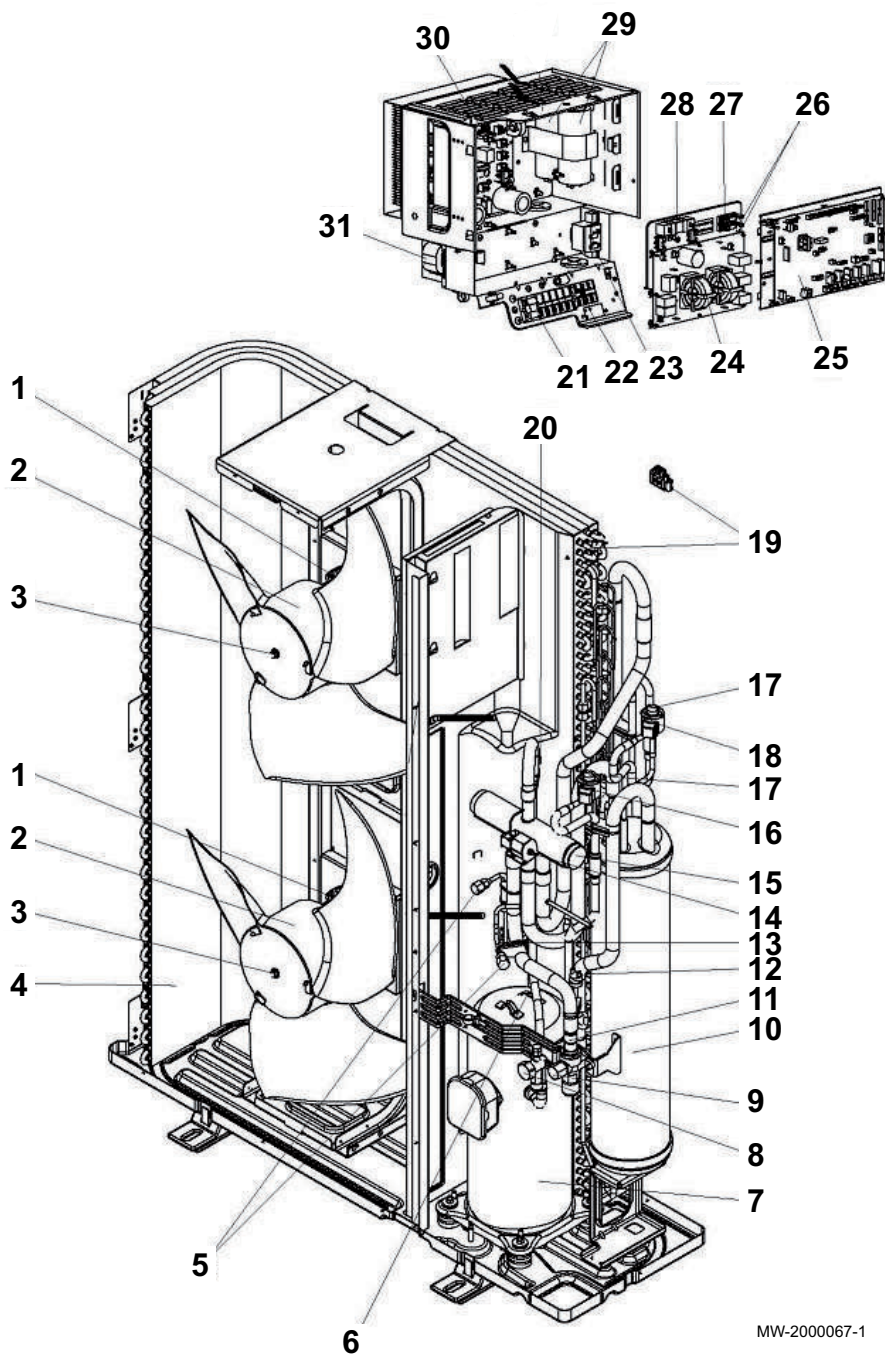

MW-2000067-1

Markers	Reference	Description
1	300027069	Fan motor
2	300027070	Fan rotor
3	300018136	Rotor holding nut
4	300027071	Condensation / absorption battery
5	300018092	Load plug
6	300027072	Sensor
7	300027073	Compressor 22TR
7	300027074	Compressor 27TR
8	300027075	3/8" stop valve 22TR

Markers	Reference	Description
8	300023663	1/2" stop valve 27TR
9	300027076	3/4" stop valve
10	300027077	Power receiver
11	300027078	Filter
12	300027079	HP pressure switch
13	300027079	Compressor discharge temperature sensor
14	300027080	Solenoid valve coil
15	300027081	4-way valve
16	300027082	Solenoid valve coil
17	300027083	Solenoid valve coil
18	300018127	Solenoid valve coil
19	300027085	Outside temperature sensor battery
20	300027079	HP pressure switch 22TR
20	300018123	HP pressure switch 41.5 bar 27TR
21	300018199	Terminal block
22	300027087	Terminal block
23	300027088	Coil
24	300027089	Electronic filter board
25	300029748	Central unit PCB 22TR
25	300027090	Central unit PCB 22-27TR
26	300027091	Fuse holder
27	300027092	Fuses 15A-250V
28	300018154	Resistance
29	300027093	Condenser
30	300027094	Output board
30	300029749	Output board 22TR
31	300027095	Coil
	300027096	Sensor battery inlet
	300018118	Fuses 6,3A-250V
	300018131	Silencer

9.2.5. Indoor module

■ Casing

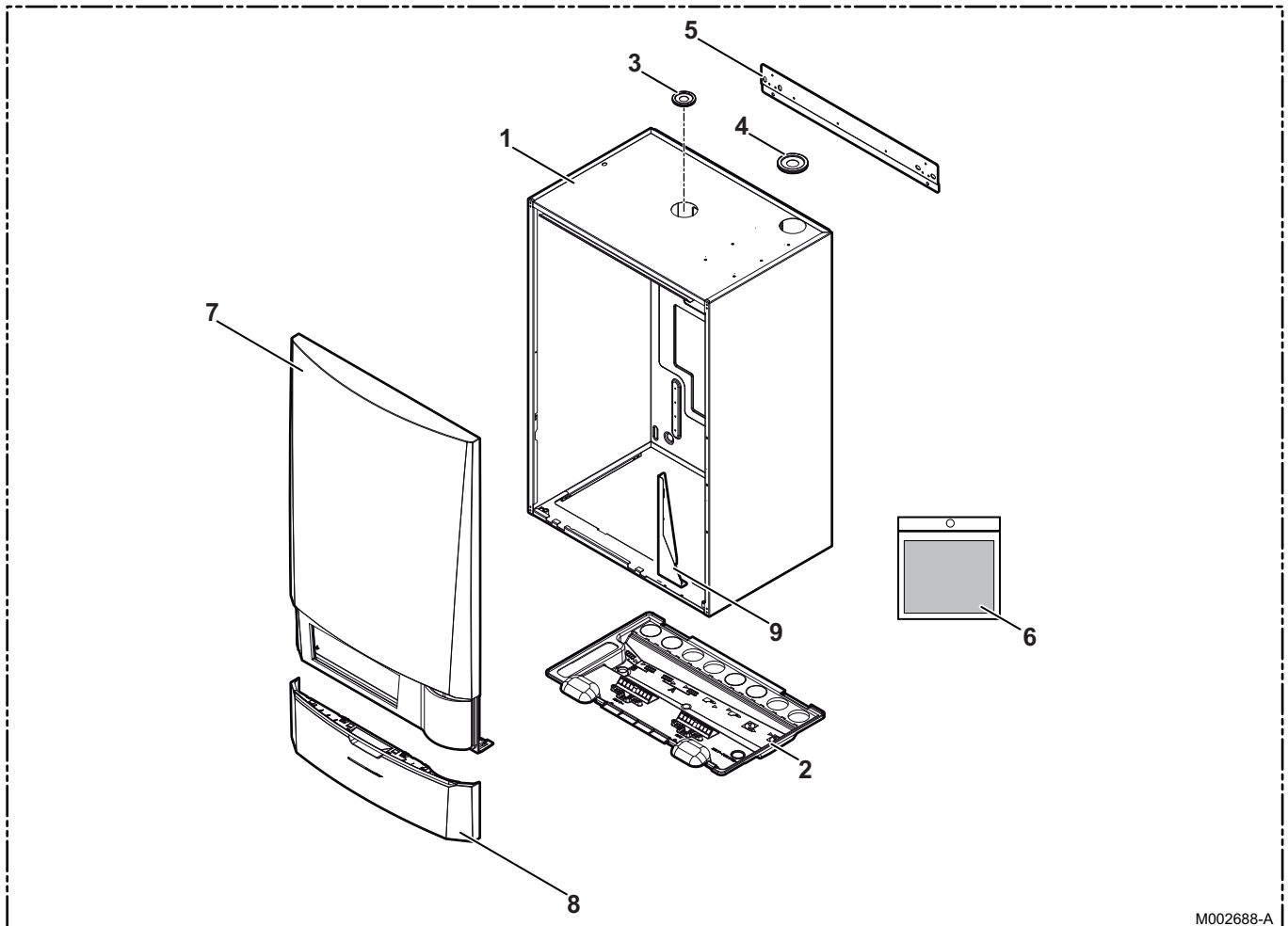

M002688-A

Markers	Reference	Description
1	300025324	Assembled casing
2	300025281	Casing bottom
3	55125	Pipe feed
4	95320588 55125	Pipe feed (Hydraulic additional heating) (Electrical back-up)
5	300027772	Cross-bar support
6	200004802	Accessories bag
7	S101309	Front panel
8	S101297	Control panel cover
9	200020022	Blockage

■ Other components

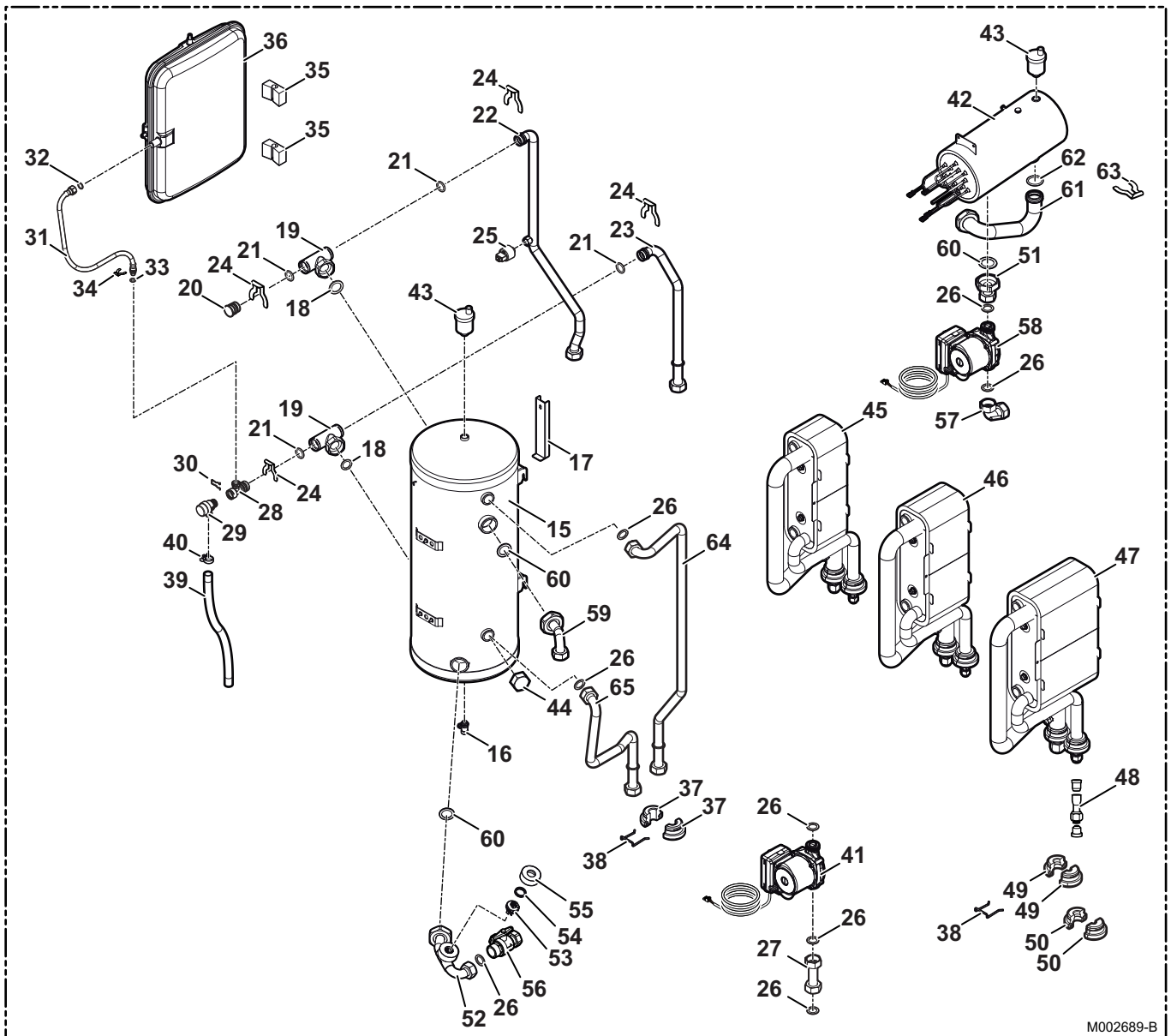

M002689-B

Markers	Reference	Description
15	300025284	tank
16	0295174	Drain cock
17	300025364	Tank blocking plate
18	95013063	Fibre gasket 38x27x2
19	300025388	Quick T connection
20	300025325	Quick T connection plug
21	95023311	O-ring 21x3.5 EPDM
22	300025265	Complete tank heating outlet pipe
23	300025246	Heating return pipe
24	300023113	Pin (DN20)
25	300000831	Electronic manometer
26	95013062	Green seal 30x21x2
27	300025257	Complete 3-way valve heating flow pipe
28	300025387	Tube connection valve of safety

Markers	Reference	Description
29	115749	Safety valve
30	116552	Safety valve pin clip
31	300025392	10-3/8" hose
32	95013058	Gasket 14x8x2
33	95023308	O-ring 9.19x2.62 EPDM
34	300024235	10 blocking pin
35	110865	Wedge for expansion vessel base
36	300025395	Expansion vessel
37	300025285	22 mm pipe spacer
38	300025361	Spacer clip
39	300003563	PVC pipe diameter 20x16
40	300025444	Flexible fastening
41	300027011	Circulator UPM2 15-70 9H 130
42	300025332	12 kW reheater
43	85000023	3/8" automatic air bleed valve
44	94950198	Brass plug - 1"
45	200019610	Plate heat exchanger - 4-8kW
46	200019611	Plate heat exchanger - 11-16kW
47	200019612	Plate heat exchanger - 22-27kW
48	300025567	Weld-on flare-type connection adapter - 22-27kW
49	300025290	Spacer - 3/8" - 4-8, 11-16 kW
49	300025288	Spacer - 1/2" - 22-27kW
50	300025291	Spacer - 5/8" - 4-8, 11-16kW
50	300025289	Spacer - 3/4" - 22-27kW
51	300025263	Complete reheater heating pump pipe
53	300025396	Detector head
54	300025363	Corrugated spring
55	300025329	Flow switch nut
56	300025385	Valve with 1"x1" filter
57	300025242	Complete exchanger heating pump pipe
58	300027010	Circulator UPM2 15-70 9H 130
59	300025244	Complete tank heating pump pipe
60	95013064	Green seal 44x32x2
61	300025231	Complete tank reheater pipe
62	300025397	34x4 O-ring
63	300025423	Pin Ø 35
64	300025235	Complete hydraulic back-up return pipe
65	300025237	Complete hydraulic back-up flow pipe

■ Control panel

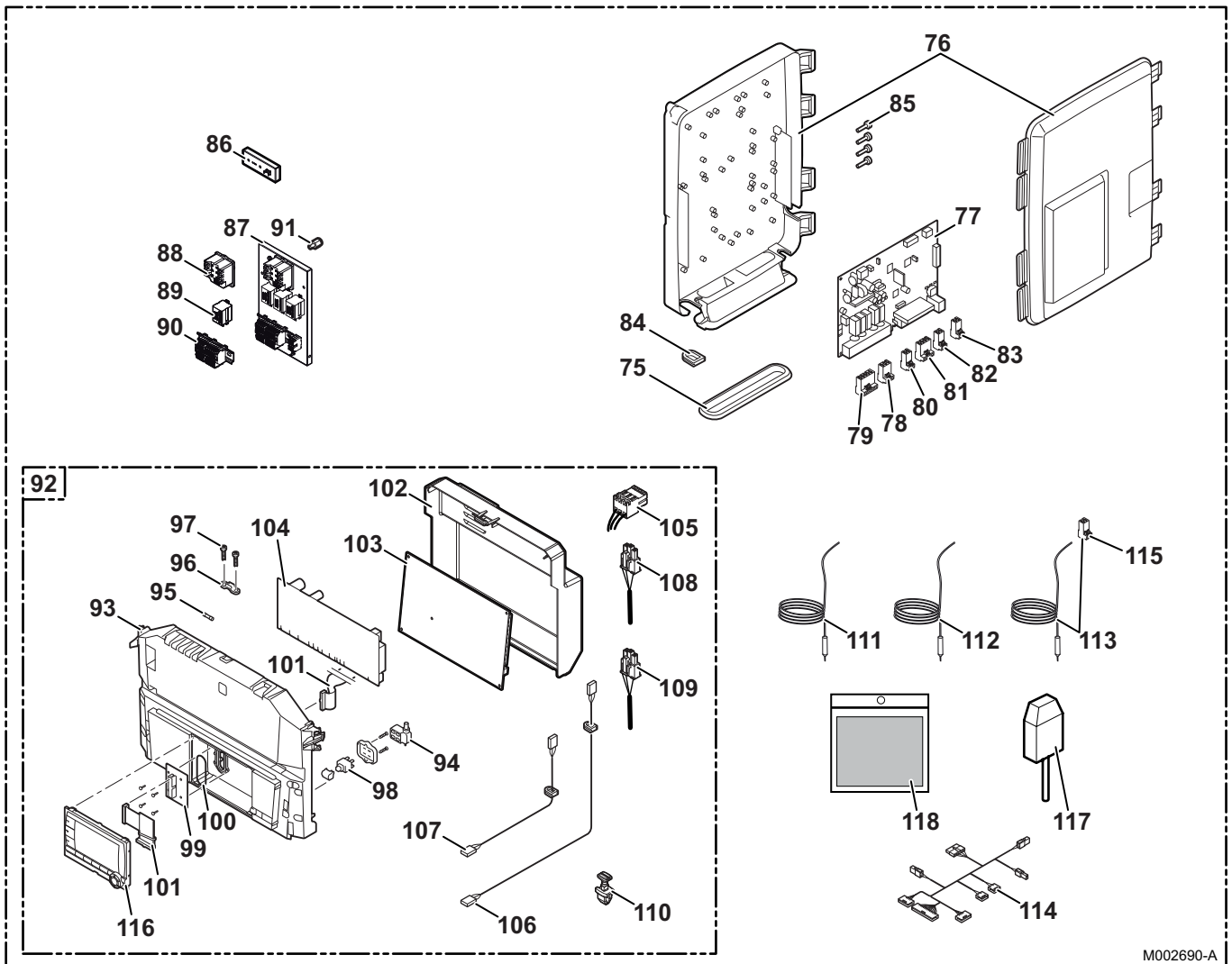

M002690-A

Markers	Reference	Description
75	S100869	Gasket SCU
76	S100860	SCU block
77	7614017	Board SCU MIT-HT
78	300009074	3 pin connector
79	300009081	5 pin connector
80	300009071	2 pin connector 0-10 V
81	300009102	4-pin connector telephone relay
82	300008954	2-pin connector room temperature sensor
83	300009070	2 pt connector outside temperature sensor
84	S100862	SCU grommet
85	S62185	Screw KB30x8 (10 pieces)
86	300027019	electrical support
87	300025393	Electrical back-up panel
88	300023302	T-STAT COTHERM BSDP 0002
89	96568001	Relay Finder - 220 V - 30 A
90	300026067	Through-feed terminal unit
91	300025400	Spacer
92	7615862	Table

Markers	Reference	Description
93	111727	Panel fascia
94	S100841	230 V switch cable
95	95340249	6.3 AT fuse
96	S59372	Fixing clamp
97	S59367	Screw KB35x12 (10 pieces)
98	300026345	Switch
99	119450	Flat cable connection board
100	119458	42x1.5 O-ring
101	S101663	Connection ramps
102	300025283	Rear cover
103	7614035	Interface PCB *1
104	7618169	PCU 194 control board HT
105	300026148	cable form - 24 V
106	S100847	BUS cable - X11
107	S100843	SCU230 V power cable - X2
108	300026153	Heating pump cable
109	300026152	Exchanger pump cable
110	300026155	Board lock
111	300026149	Heating sensor
112	300026150	Liquid sensor
113	300025712	Tank sensor + Connector
114	300026151	Interface board power cable
115	300024269	2-pin connector
116	S101249	Display plate
117	95362450	Outside sensor
118	200020910	Screws

DE DIETRICH THERMIQUE S.A.S

www.dedietrich-thermique.fr
 Direction des Ventes France
 57, rue de la Gare
 F- 67580 MERTZWILLER
 ☎ +33 (0)3 88 80 27 00
 ✉ +33 (0)3 88 80 27 99

DE DIETRICH REMEHA GmbH

www.remeha.de
 Rheiner Strasse 151
 D- 48282 EMSDETTEN
 ☎ +49 (0)25 72 / 9161-0
 ✉ +49 (0)25 72 / 9161-102
 info@remeha.de

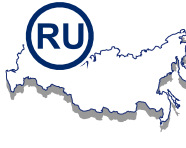
DE DIETRICH

www.dedietrich-otoplenie.ru
 129164, Россия, г. Москва
 Зубарев переулок, д. 15/1
 Бизнес-центр «Чайка Плаза»,
 офис 309
 ☎ +7 (495) 221-31-51
 info@dedietrich.ru

VAN MARCKE

www.vanmarcke.be
 Weggevoerdenlaan 5
 B- 8500 KORTRIJK
 ☎ +32 (0)56/23 75 11

NEUBERG S.A.

www.dedietrich-heating.com
 39 rue Jacques Stas
 L- 2010 LUXEMBOURG
 ☎ +352 (0)2 401 401

DE DIETRICH THERMIQUE Iberia S.L.U.

www.dedietrich-calefaccion.es
 C/Salvador Espriu, 11
 08908 L'HOSPITALET de LLOBREGAT
 ☎ +34 935 475 850
 info@dedietrich-calefaccion.es

DE DIETRICH SERVICE

www.dedietrich-heiztechnik.com
 ☎ Freecall 0800 / 201608

WALTER MEIER (Klima Schweiz) AG

www.waltermeier.com
 Bahnstrasse 24
 CH-8603 SCHWERZENBACH
 +41 (0) 44 806 44 24
 Serviceline +41 (0)8 00 846 846
 ☎ +41 (0) 44 806 44 25
 ch.klima@waltermeier.com

WALTER MEIER (Climat Suisse) SA

www.waltermeier.com
 Z.I. de la Veyre B, St-Légier
 CH-1800 VEVEY 1
 ☎ +41 (0) 21 943 02 22
 Serviceline +41 (0)8 00 846 846
 ☎ +41 (0) 21 943 02 33
 ch.climat@waltermeier.com

DUEDI S.r.l.

www.duediclima.it
 Distributore Ufficiale Esclusivo
 De Dietrich-Thermique Italia
 Via Passatore, 12 - 12010
 San Defendente di Cervasca
 CUNEO
 ☎ +39 0171 857170
 ✉ +39 0171 687875
 info@duediclima.it

DE DIETRICH

www.dedietrich-heating.com
 Room 512, Tower A, Kelun Building
 12A Guanghua Rd, Chaoyang District
 C-100020 BEIJING
 ☎ +86 (0)106.581.4017
 +86 (0)106.581.4018
 +86 (0)106.581.7056
 ☎ +86 (0)106.581.4019
 contactBJ@dedietrich.com.cn

BDR Thermea (Czech republic) s.r.o

www.dedietrich.cz
 Jeseniova 2770/56
 130 00 Praha 3
 ☎ +420 271 001 627
 info@dedietrich.cz

CE**R410A**

M001476-C

AD001-AJ

© Copyright

All technical and technological information contained in these technical instructions, as well as any drawings and technical descriptions supplied, remain our property and shall not be multiplied without our prior consent in writing.

25/06/2014



7616371-001-04

De Dietrich

DE DIETRICH THERMIQUE

57, rue de la Gare F- 67580 MERTZWILLER - BP 30